

## European Technical Assessment

## ETA-01/0012 of 23/06/2014

English translation prepared by CSTB - Original version in French language

### General Part

Nom commercial  
*Trade name*

**SORMAT PFG LB / SB / ES**

Famille de produit  
*Product family*

**Cheville métallique en acier galvanisé, à expansion par vissage à couple contrôlé, de fixation dans le béton non fissuré : diamètres M6, M8, M10 et M12.**

***Torque-controlled expansion anchor, made of galvanised steel, for use in non cracked concrete: sizes M6, M8, M10 and M12.***

Titulaire  
*Manufacturer*

SORMAT OY  
Harjutie 5  
FIN-21290 Rusko  
Finlande

Usine de fabrication  
*Manufacturing plants*

Usine 6

Cette évaluation contient:  
*This Assessment contains*

14 pages incluant 11 annexes qui font partie intégrante de cette évaluation  
*14 pages including 11 annexes which form an integral part of this assessment*

Base de l'ETE  
*Basis of ETA*

ETAG 001, Version April 2013, utilisée en tant que EAD  
*ETAG 001, Edition April 2013 used as EAD*

Cette évaluation remplace:  
*This Assessment replaces*

ATE 01/0012 valide du 09/05/2011 au 09/05/2016  
*ETA-01/0012 with validity from 09/05/2011 to 09/05/2016*

*Translations of this European Technical Assessment in other languages shall fully correspond to the original issued document and should be identified as such. Communication of this European Technical Assessment, including transmission by electronic means, shall be in full. However, partial reproduction may be made, with the written consent of the issuing Technical Assessment Body. Any partial reproduction has to be identified as such.*

## Specific Part

### 1 Technical description of the product

The PFG bolt type LB, ES and SB anchor in the range of M6 to M12 is an anchor made of galvanised steel, which is placed into a drilled hole and anchored by torque-controlled expansion. The LB version is the complete version with screw and washer. The ES version is made of the expansion system (shield, cone, ferule and coil spring) and can only be used with a steel grade 8.8 ISO 898-1 bolt and a washer whose material characteristics are given in Annex A2. The version SB consists of a threaded rod with conical end instead of the screw and of the cone.

The illustration and the description of the product are given in Annexes A.

### 2 Specification of the intended use

The performances given in Section 3 are only valid if the anchor is used in compliance with the specifications and conditions given in Annexes B.

The provisions made in this European technical assessment are based on an assumed working life of the anchor of 50 years. The indications given on the working life cannot be interpreted as a guarantee given by the producer, but are to be regarded only as a means for choosing the right products in relation to the expected economically reasonable working life of the works.

### 3 Performance of the product

#### 3.1 Mechanical resistance and stability (BWR 1)

Essential characteristic	Performance
Characteristic tension resistance acc. ETAG001, Annex C	See Annex C 1
Characteristic shear resistance acc. ETAG001, Annex C	See Annex C 1
Characteristic tension resistance acc. CEN/TS 1992-4	See Annex C 4
Characteristic shear resistance acc. CEN/TS 1992-4	See Annex C 4
Displacements	See Annex C 7

#### 3.2 Safety in case of fire (BWR 2)

Essential characteristic	Performance
Reaction to fire	Anchorage satisfy requirements for Class A1
Characteristic tension resistance under fire acc. ETAG001, Annex C	See Annex C2
Characteristic shear resistance under fire acc. ETAG001, Annex C	See Annex C3
Characteristic tension resistance under fire acc. CEN/TS 1992-4	See Annex C5
Characteristic shear resistance under fire acc. CEN/TS 1992-4	See Annex C6

#### 3.3 Hygiene, health and the environment (BWR 3)

Regarding dangerous substances contained in this European technical approval, there may be requirements applicable to the products falling within its scope (e.g. transposed European legislation and national laws, regulations and administrative provisions). In order to meet the provisions of the Construction Products Directive, these requirements need also to be complied with, when and where they apply.

### 3.4 Safety in use (BWR 4)

For Basic requirement Safety in use the same criteria are valid as for Basic Requirement Mechanical resistance and stability.

### 3.5 Protection against noise (BWR 5)

Not relevant.

### 3.6 Energy economy and heat retention (BWR 6)

Not relevant.

### 3.7 Sustainable use of natural resources ( BWR 7)

For the sustainable use of natural resources no performance was determined for this product.

### 3.8 General aspects relating to fitness for use

Durability and Serviceability are only ensured if the specifications of intended use according to Annex B1 are kept.

## 4 Assessment and verification of constancy of performance (AVCP)

According to the Decision 96/582/EC of the European Commission<sup>1</sup>, as amended, the system of assessment and verification of constancy of performance (see Annex V to Regulation (EU) No 305/2011) given in the following table apply.

Product	Intended use	Level or Class	System
Metal anchors for use in concrete	For fixing and/or supporting to concrete, structural elements (which contributes to the stability of the works) or heavy units	—	1

## 5 Technical details necessary for the implementation of the AVCP system

Technical details necessary for the implementation of the Assessment and verification of constancy of performance (AVCP) system are laid down in the control plan deposited at Centre Scientifique et Technique du Bâtiment.

The manufacturer shall, on the basis of a contract, involve a notified body approved in the field of anchors for issuing the certificate of conformity CE based on the control plan.

Issued in Marne La Vallée on 23-06-2014 by  
Charles Baloche  
Directeur technique

*The original French version is signed*

<sup>1</sup>

Official Journal of the European Communities L 254 of 08.10.1996

### SORMAT PFG anchor

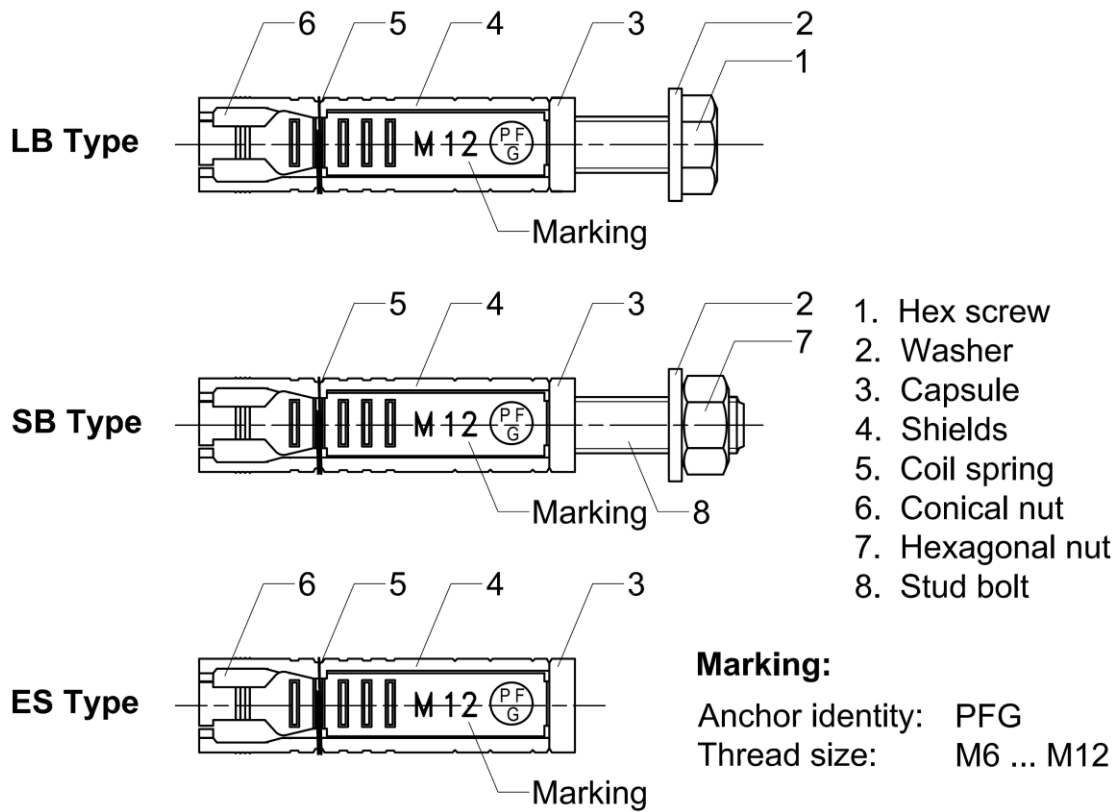

### SORMAT PFG anchor after installation (type LB)

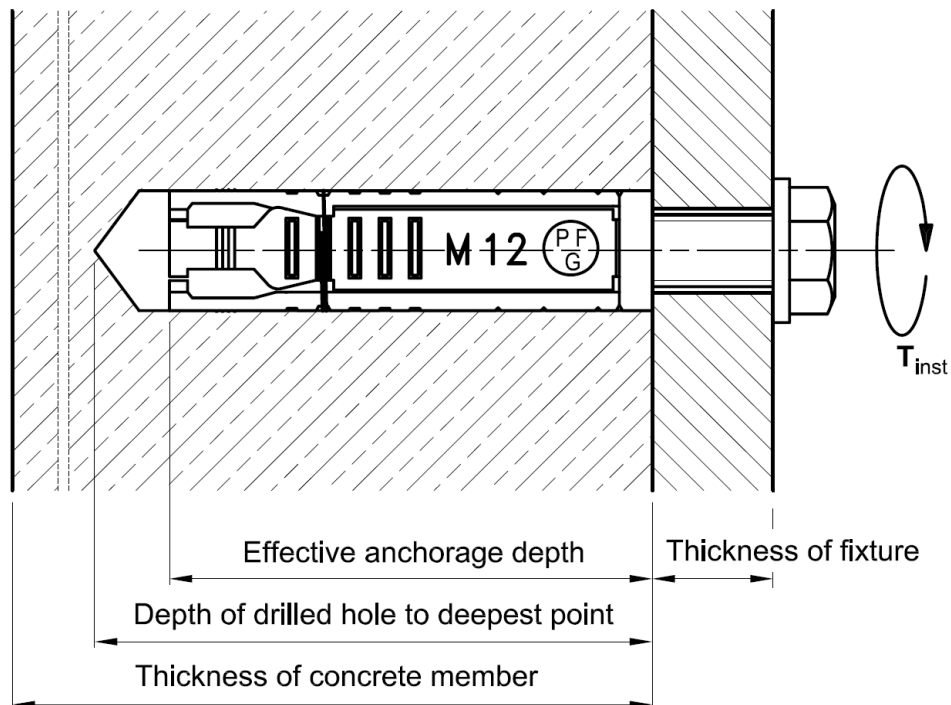

### SORMAT PFG anchor LB / SB / ES

Product description  
 Installation condition

Annex A1

## SORMAT PFG anchor

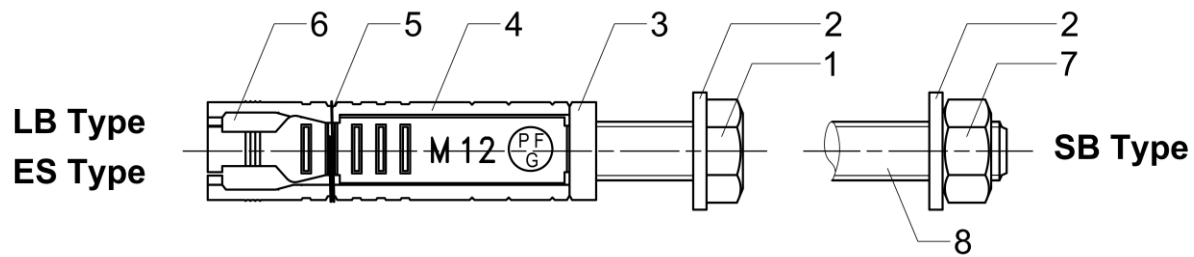

**Table A1 : Materials PFG <sup>1)</sup>**

Part	Designation	Material	Coating <sup>2)</sup>
1	Hexagonal Bolt	DIN 933 (EN ISO 4017) / DIN 931 (EN ISO 4014) EN ISO 898-1: property class 8.8	zinc electroplated
2	Washer	DIN 125 (EN ISO 7089) / DIN 440 (EN ISO 7094) / DIN 9021 (EN ISO 7093)	zinc electroplated
3	Capsule	Cold formed steel	zinc electroplated
4	Shields	Cold formed steel	zinc electroplated
5	Coil Spring	Steel wire DIN 17223 BL1, Class B	-
6	Conical Nut	EN ISO 898-2: property class 8	zinc electroplated
7	Hexagonal Nut	DIN 934 (EN ISO 4032) EN ISO 898-2: property class 8	zinc electroplated
8	Stud Bolt	EN ISO 898-1: property class 8.8	zinc electroplated

<sup>1)</sup> The same type of anchor with sherardized/blackdized shields is not covered by this ETA.

<sup>2)</sup> Parts 1-4 and 6-8 are zinc electroplated according to EN ISO 4042  $\geq 5\mu\text{m}$  and bright passivated.

### SORMAT PFG anchor LB / SB / ES

Product description  
 Materials

Annex A2

## Specifications of intended use

### Anchorage subject to:

- Static, quasi-static and loads under fire

### Base materials:

- Non-cracked concrete.
- Reinforced or unreinforced normal weight concrete of strength classes C 20/25 at least to C50/60 at most according to EN 206: 2000-12.

### Use conditions (Environmental conditions):

- Structures subject to dry indoor conditions, indoor with temporary condensation.

### Design:

- The anchorages are designed in accordance with the ETAG001 Annex C "Design Method for Anchorages" or CEN/TS 1992-4-4 "Design of fastenings for use in concrete" under the responsibility of an engineer experienced in anchorages and concrete work.
- For application with resistance under fire exposure the anchorages are designed in accordance with method given in TR020 "Evaluation of Anchorage in Concrete concerning Resistance to Fire".
- Verifiable calculation notes and drawings are prepared taking account of the loads to be anchored. The position of the anchor is indicated on the design drawings.

### Installation:

- Anchor installation carried out by appropriately qualified personnel and under the supervision of the person responsible for technical matters of the site.
- Use of the anchor only as supplied by the manufacturer without exchanging the components of an anchor.
- Anchor installation in accordance with the manufacturer's specifications and drawings and using the appropriate tools.
- Effective anchorage depth, edge distances and spacing not less than the specified values without minus tolerances.
- Hole drilling by hammer drill.
- Cleaning of the hole of drilling dust
- Application of specified torque moment using a calibrated torque wrench
- In case of aborted hole, drilling of new hole at a minimum distance of twice the depth of the aborted hole, or smaller distance provided the aborted drill hole is filled with high strength mortar and no shear or oblique tension loads in the direction of aborted hole.

**SORMAT PFG anchor LB / SB / ES**

**Intended Use  
Specifications**

**Annex B1**

**Table B1: Anchor dimensions**

Main dimensions					Washer <sup>*1)</sup>			Hexagonal Bolt <sup>*2)</sup> (LB type)		Hexagonal Nut <sup>*3)</sup> (SB type)	
type LB / SB / ES	Size	L [mm]	d [mm]	d <sub>nom</sub> [mm]	s [mm]	d <sub>1</sub> [mm]	d <sub>2</sub> [mm]	sw [mm]	k [mm]	sw [mm]	m [mm]
6 - t <sub>fix</sub>	M6	40	6	10	1.6 / 1.6 / 2	6.4 / 6.4 / 6.6	12 / 18 / 22	10	4.0	10	5.2 / 6.5
8 - t <sub>fix</sub>	M8	50	8	14	1.6 / 2 / 2	8.4 / 8.4 / 9	16 / 24 / 28	13	5.3	13	6.8 / 8.0
10 - t <sub>fix</sub>	M10	60	10	16	2 / 2.5 / 3	10.5 / 10.5 / 11	20 / 30 / 34	16 / 17	6.4	16 / 17	8.4 / 10
12 - t <sub>fix</sub>	M12	80	12	20	2.5 / 3 / 4	13 / 13 / 13.5	24 / 37 / 44	18 / 19	7.5	18 / 19	10.8 / 13

\*1): EN ISO 7089 / EN ISO 7093 / EN ISO 7094

\*2): EN ISO 4017 and EN ISO 4014 / DIN 933 and DIN 931

\*3): EN ISO 4032 / DIN 934

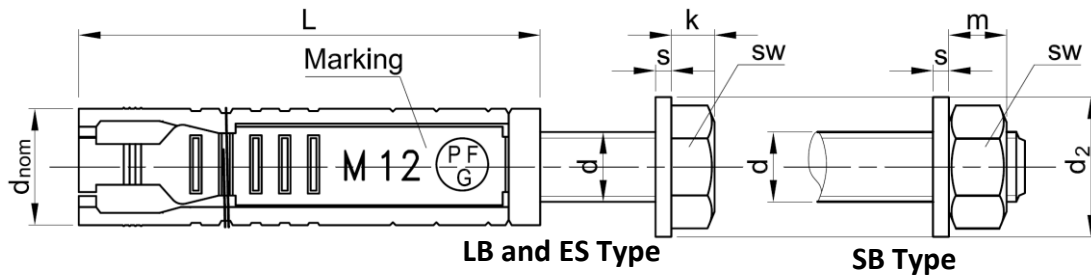

**Table B2: Installation data**

SORMAT PFG anchor LB / SB / ES			Anchor size			
			M6	M8	M10	M12
Drill hole diameter	d <sub>0</sub>	[mm]	10	14	16	20
Cutting diameter at the upper tolerance limit (maximum diameter bit)	d <sub>cut,max</sub> ≤	[mm]	10.45	14.5	16.5	20.55
Depth of drilled hole to deepest point	h <sub>1</sub> ≥	[mm]	45	55	65	85
Effective anchorage depth	h <sub>ef</sub>	[mm]	40	50	60	80
Diameter of clearance hole in the fixture	d <sub>f</sub> ≤	[mm]	7	9	11	13
Thickness of fixture	t <sub>fix,min...max</sub>	[mm]	0...100	0...120	0...140	0...160
Required torque	T <sub>inst</sub>	[Nm]	10	25	50	85
Minimum thickness of concrete member	h <sub>min</sub>	[mm]	100	100	120	160
Minimum spacing	s <sub>min</sub>	[mm]	60	75	90	120
Minimum edge distance	c <sub>min</sub>	[mm]	60	75	90	120

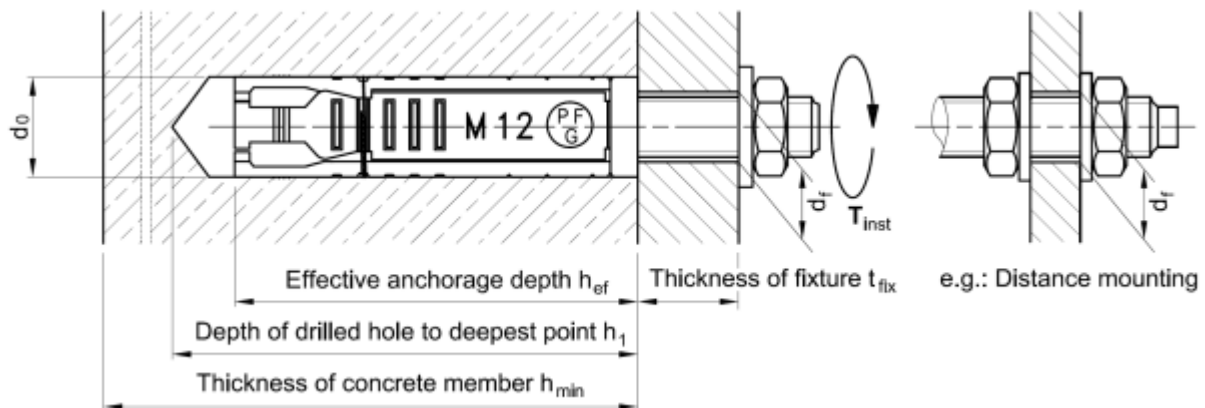

**SORMAT PFG anchor LB / SB / ES**

**Intended Use**  
 Installation parameters

**Annex B2**

**Table C1: Characteristic values for tension loads in case of static and quasi static loading for design method A acc. ETAG 001, Annex C**

SORMAT PFG anchor LB / SB / ES			Anchor size			
			M6	M8	M10	M12
<b>Steel failure</b>						
Characteristic resistance (reduced part)	$N_{Rk,s}$	[kN]	16	29	46	67
Partial safety factor	$\gamma_{Ms}^{1)}$	[-]	1.50			
<b>Pull-out failure</b>						
Characteristic resistance in <b>non-cracked</b> concrete C20/25	$N_{Rk,p}^0$	[kN]	5	9	12	16
Partial safety factor	$\gamma_{Mp}^{1)}$	[-]	1.50 <sup>2)</sup>			
<b>Concrete cone failure</b>						
Effective anchorage depth	$h_{ef}$	[mm]	40	50	60	80
Spacing	$S_{cr,N}$	[mm]	120	150	180	240
Edge distance	$C_{cr,N}$	[mm]	60	75	90	120
Partial safety factor	$\gamma_{Mc}^{1)}$	[-]	1.50 <sup>2)</sup>			
<b>Concrete splitting failure</b>						
Spacing ( splitting )	$S_{cr,sp}$	[mm]	240	300	360	480
Edge distance ( splitting )	$C_{cr,sp}$	[mm]	120	150	180	240
Partial safety factor	$\gamma_{Msp}^{1)}$	[-]	1.50 <sup>2)</sup>			

<sup>1)</sup> In the absence of other national regulations

<sup>2)</sup> The installation safety factor of  $\gamma_2 = 1,0$  is included.

**Table C2: Characteristic values for shear loads in case of static and quasi static loading for design method A acc. ETAG 001, Annex C**

SORMAT PFG anchor LB / SB / ES			Anchor size			
			M6	M8	M10	M12
<b>Steel failure without lever arm</b>						
Characteristic resistance	$V_{Rk,s}$	[kN]	8	14	23	33
Partial safety factor	$\gamma_{Ms}^{1)}$	[-]	1.25			
<b>Steel failure with lever arm</b>						
Characteristic resistance	$M_{Rk,s}^0$	[Nm]	12	30	60	105
Partial safety factor	$\gamma_{Ms}^{1)}$	[-]	1.25			
<b>Concrete pryout failure</b>						
Factor in eq. (5.6) of ETAG Annex C, § 5.2.3.3	k	[-]	1		2	
Partial safety factor	$\gamma_{Mcp}^{1)}$	[-]	1.50 <sup>2)</sup>			
<b>Concrete edge failure</b>						
Effective length of anchor under shear load	$l_f$	[mm]	26	33	40	53
Outside diameter of anchor	$d_{nom}$	[mm]	10	14	16	20
Partial safety factor	$\gamma_{Mc}^{1)}$	[-]	1.50 <sup>2)</sup>			

**SORMAT PFG anchor LB / SB / ES**

Design according to **ETAG 001, Annex C**  
Characteristic resistance under tension and shear loads

**Annex C1**



**Table C3: Characteristic tension resistance under fire exposure for design method A according to ETAG 001, Annex C**

SORMAT PFG anchor LB / SB / ES			Anchor size			
			M6	M8	M10	M12
<b>Steel failure</b>						
Characteristic resistance	R30 $N_{Rk,s,fi}$	[kN]	0.2	0.4	0.9	1.7
	R60 $N_{Rk,s,fi}$	[kN]	0.2	0.3	0.8	1.3
	R90 $N_{Rk,s,fi}$	[kN]	0.1	0.3	0.6	1.1
	R120 $N_{Rk,s,fi}$	[kN]	0.1	0.2	0.5	0.8
<b>Pull-out failure</b>						
Characteristic resistance	R30 $N_{Rk,p,fi}$	[kN]	1.3	2.3	3.0	4.0
	R60 $N_{Rk,p,fi}$	[kN]	1.3	2.3	3.0	4.0
	R90 $N_{Rk,p,fi}$	[kN]	1.3	2.3	3.0	4.0
	R120 $N_{Rk,p,fi}$	[kN]	1.0	1.8	2.4	3.2
<b>Concrete cone and splitting failure <sup>1)</sup></b>						
Characteristic resistance	R30 $N_{Rk,c,fi}$	[kN]	1.8	3.2	5.0	10.3
	R60 $N_{Rk,c,fi}$	[kN]	1.8	3.2	5.0	10.3
	R90 $N_{Rk,c,fi}$	[kN]	1.8	3.2	5.0	10.3
	R120 $N_{Rk,c,fi}$	[kN]	1.5	2.5	4.0	8.2
Spacing	$s_{cr,N,fi}$	[mm]	4 x $h_{ef}$			
	$s_{min}$	[mm]	60	75	90	120
Edge distance	$c_{cr,N,fi}$	[mm]	2 x $h_{ef}$			

<sup>1)</sup> As a rule, splitting failure can be neglected when cracked concrete and reinforcement is assumed.

Design under fire exposure is performed according to the design method given in TR 020. Under fire exposure usually cracked concrete is assumed. The design equations are given in TR 020 § 2.2.1.

TR 020 covers design for fire exposure from one side. For fire attack from more than one side the edge distance must be increased to  $c_{min} \geq 300$  mm and  $\geq 2 \cdot h_{ef}$ .

In the absence of other national regulations the partial safety factor for resistance under fire exposure  $\gamma_{M,fi} = 1,0$  is recommended.

<b>SORMAT PFG anchor LB / SB / ES</b>	<b>Annex C2</b>
Design according to <u>ETAG 001, Annex C</u> Characteristic tension resistance under fire exposure	

**Table C4: Characteristic shear resistance under fire exposure for design method A according to ETAG 001, Annex C**

SORMAT PFG anchor LB / SB / ES			Anchor size			
			M6	M8	M10	M12
<b>Steel failure without lever arm</b>						
Characteristic resistance	R30 $V_{Rk,s,fi}$	[kN]	0.2	0.4	0.9	1.7
	R60 $V_{Rk,s,fi}$	[kN]	0.2	0.3	0.8	1.3
	R90 $V_{Rk,s,fi}$	[kN]	0.2	0.3	0.6	1.1
	R120 $V_{Rk,s,fi}$	[kN]	0.1	0.2	0.5	0.8
<b>Steel failure with lever arm</b>						
Characteristic resistance	R30 $M_{Rk,s,fi}^0$	[kN]	0.2	0.4	1.1	2.6
	R60 $M_{Rk,s,fi}^0$	[kN]	0.1	0.3	1.0	2.0
	R90 $M_{Rk,s,fi}^0$	[kN]	0.1	0.3	0.7	1.7
	R120 $M_{Rk,s,fi}^0$	[kN]	0.1	0.2	0.6	1.3
<b>Concrete pryout failure</b>						
Factor in eq. (5.6) of ETAG Annex C, § 5.2.3.3	k	[-]	1		2	
Characteristic resistance	R30 $N_{Rk,cp,fi}$	[kN]	1.8	6.4	10.0	20.6
	R60 $N_{Rk,cp,fi}$	[kN]	1.8	6.4	10.0	20.6
	R90 $N_{Rk,cp,fi}$	[kN]	1.8	6.4	10.0	20.6
	R120 $N_{Rk,cp,fi}$	[kN]	1.5	5.1	8.0	16.5
<b>Concrete edge failure</b>						
The initial value $V_{Rk,c,fi}^0$ of the characteristic resistance in concrete C20/25 to C50/60 under fire exposure may be determined by:						
$V_{Rk,c,fi}^0 = 0,25 \times V_{Rk,c}^0 \quad (\leq R90) \qquad V_{Rk,c,fi}^0 = 0,20 \times V_{Rk,c}^0 \quad (R120)$						
with $V_{Rk,c}^0$ initial value of the characteristic resistance in cracked concrete C20/25 under normal temperature.						

Design under fire exposure is performed according to the design method given in TR 020. Under fire exposure usually cracked concrete is assumed. The design equations are given in TR 020 § 2.2.1.

TR 020 covers design for fire exposure from one side. For fire attack from more than one side the edge distance must be increased to  $c_{min} \geq 300$  mm and  $\geq 2 \cdot h_{ef}$ .

In the absence of other national regulations the partial safety factor for resistance under fire exposure  $\gamma_{M,fi} = 1,0$  is recommended.

<b>SORMAT PFG anchor LB / SB / ES</b>	<b>Annex C3</b>
Design according to <u>ETAG 001, Annex C</u> Characteristic shear resistance under fire exposure	

**Table C5: Characteristic values for tension loads in case of static and quasi static loading for design method A according to CEN/TS 1992-4**

SORMAT PFG anchor LB / SB / ES			Anchor size				
			M6	M8	M10	M12	
<b>Steel failure</b>							
Characteristic resistance (reduced part)	$N_{Rk,s}$	[kN]	16	29	46	67	
Partial safety factor	$\gamma_{Ms}^{1)}$	[-]	1.50				
<b>Pull-out failure</b>							
Characteristic resistance in non-cracked concrete C20/25	$N^0_{Rk,p}$	[kN]	5	9	12	16	
Partial safety factor	$\gamma_{Mp}^{1)}$	[-]	1.50 <sup>2)</sup>				
<b>Concrete cone and splitting failure</b>							
Effective anchorage depth	$h_{ef}$	[mm]	40	50	60	80	
Factor for non-cracked concrete	$k_{cr}$	[-]	10.1				
Partial safety factor	$\gamma_{Mc} = \gamma_{Msp}^{1)}$	[-]	1.50 <sup>2)</sup>				
Spacing	concrete cone failure	$S_{cr,N}$	[mm]	120	150	180	240
	splitting failure	$S_{cr,sp}$	[mm]	240	300	360	480
Edge distance	concrete cone failure	$C_{cr,N}$	[mm]	60	75	90	120
	splitting failure	$C_{cr,sp}$	[mm]	120	150	180	240

<sup>1)</sup> In the absence of other national regulations.

<sup>2)</sup> The installation safety factor of  $\gamma_2 = 1.0$  is included.

**Table C6: Characteristic values for shear loads in case of static and quasi static loading for design method A according to CEN/TS 1992-4**

SORMAT PFG anchor LB / SB / ES			Anchor size			
			M6	M8	M10	M12
<b>Steel failure without lever arm</b>						
Characteristic resistance	$V_{Rk,s}$	[kN]	8	14	23	33
Factor considering ductility	$k_2$	[-]	0.8			
Partial safety factor	$\gamma_{Ms}^{1)}$	[-]	1.25			
<b>Steel failure with lever arm</b>						
Characteristic resistance	$M^0_{Rk,s}$	[Nm]	12	30	60	105
Partial safety factor	$\gamma_{Ms}^{1)}$	[-]	1.25			
<b>Concrete pryout failure</b>						
Factor in eq. (16) of CEN/TS 1992-4-4, § 6.2.2.3	$k_3$	[-]	1		2	
Partial safety factor	$\gamma_{Mcp}^{1)}$	[-]	1.50 <sup>2)</sup>			
<b>Concrete edge failure</b>						
Effective length of anchor under shear load	$l_f$	[mm]	26	33	40	53
Outside diameter of anchor	$d_{nom}$	[mm]	10	14	16	20
Partial safety factor	$\gamma_{Mc}^{1)}$	[-]	1.50 <sup>2)</sup>			

**SORMAT PFG anchor LB / SB / ES**

Design according to **CEN/TS 1992-4**  
Characteristic resistance under tension and shear loads

**Annex C4**

**Table C7: Characteristic tension resistance under fire exposure for design method A according to **CEN/TS 1992-4****

SORMAT PFG anchor LB / SB / ES			Anchor size			
			M6	M8	M10	M12
<b>Steel failure</b>						
Characteristic resistance	R30 $N_{Rk,s,fi}$	[kN]	0.2	0.4	0.9	1.7
	R60 $N_{Rk,s,fi}$	[kN]	0.2	0.3	0.8	1.3
	R90 $N_{Rk,s,fi}$	[kN]	0.1	0.3	0.6	1.1
	R120 $N_{Rk,s,fi}$	[kN]	0.1	0.2	0.5	0.8
<b>Pull-out failure</b>						
Characteristic resistance	R30 $N_{Rk,p,fi}$	[kN]	1.3	2.3	3.0	4.0
	R60 $N_{Rk,p,fi}$	[kN]	1.3	2.3	3.0	4.0
	R90 $N_{Rk,p,fi}$	[kN]	1.3	2.3	3.0	4.0
	R120 $N_{Rk,p,fi}$	[kN]	1.0	1.8	2.4	3.2
<b>Concrete cone and splitting failure <sup>1)</sup></b>						
Characteristic resistance	R30 $N_{Rk,c,fi}$	[kN]	1.8	3.2	5.0	10.3
	R60 $N_{Rk,c,fi}$	[kN]	1.8	3.2	5.0	10.3
	R90 $N_{Rk,c,fi}$	[kN]	1.8	3.2	5.0	10.3
	R120 $N_{Rk,c,fi}$	[kN]	1.5	2.5	4.0	8.2
Spacing	$s_{cr,N,fi}$	[mm]	4 x $h_{ef}$			
	$s_{min}$	[mm]	60	75	90	120
Edge distance	$c_{cr,N,fi}$	[mm]	2 x $h_{ef}$			

<sup>1)</sup> As a rule, splitting failure can be neglected when cracked concrete and reinforcement is assumed.

Design under fire exposure is performed according to the design method given in TR 020. Under fire exposure usually cracked concrete is assumed. The design equations are given in TR 020 § 2.2.1.

TR 020 covers design for fire exposure from one side. For fire attack from more than one side the edge distance must be increased to  $c_{min} \geq 300$  mm and  $\geq 2 \cdot h_{ef}$ .

In the absence of other national regulations the partial safety factor for resistance under fire exposure  $\gamma_{M,fi} = 1,0$  is recommended.

**SORMAT PFG anchor LB / SB / ES**

Design according to **CEN/TS 1992-4**  
Characteristic tension resistance under fire exposure

**Annex C5**

**Table C8: Characteristic shear resistance under fire exposure for design method A according to CEN/TS 1992-4**

SORMAT PFG anchor LB / SB / ES			Anchor size			
			M6	M8	M10	M12
<b>Steel failure without lever arm</b>						
Characteristic resistance	R30 $V_{Rk,s,fi}$	[kN]	0.2	0.4	0.9	1.7
	R60 $V_{Rk,s,fi}$	[kN]	0.2	0.3	0.8	1.3
	R90 $V_{Rk,s,fi}$	[kN]	0.2	0.3	0.6	1.1
	R120 $V_{Rk,s,fi}$	[kN]	0.1	0.2	0.5	0.8
<b>Steel failure with lever arm</b>						
Characteristic resistance	R30 $M^0_{Rk,s,fi}$	[kN]	0.2	0.4	1.1	2.6
	R60 $M^0_{Rk,s,fi}$	[kN]	0.1	0.3	1.0	2.0
	R90 $M^0_{Rk,s,fi}$	[kN]	0.1	0.3	0.7	1.7
	R120 $M^0_{Rk,s,fi}$	[kN]	0.1	0.2	0.6	1.3
<b>Concrete pryout failure</b>						
Factor in eq. (16) of CEN/TS 1992-4-4, § 6.2.2.3	$k_3$	[-]	1		2	
Characteristic resistance	R30 $N_{Rk,cp,fi}$	[kN]	1.8	6.4	10.0	20.6
	R60 $N_{Rk,cp,fi}$	[kN]	1.8	6.4	10.0	20.6
	R90 $N_{Rk,cp,fi}$	[kN]	1.8	6.4	10.0	20.6
	R120 $N_{Rk,cp,fi}$	[kN]	1.5	5.1	8.0	16.5
<b>Concrete edge failure</b>						
The initial value $V^0_{Rk,c,fi}$ of the characteristic resistance in concrete C20/25 to C50/60 under fire exposure may be determined by:						
$V^0_{Rk,c,fi} = 0,25 \times V^0_{Rk,c} \quad (\leq R90) \qquad V^0_{Rk,c,fi} = 0,20 \times V^0_{Rk,c} \quad (R120)$						
with $V^0_{Rk,c}$ initial value of the characteristic resistance in cracked concrete C20/25 under normal temperature.						

Design under fire exposure is performed according to the design method given in TR 020.

Under fire exposure usually cracked concrete is assumed. The design equations are given in TR 020, § 2.2.2.

TR 020 covers design for fire exposure from one side. For fire attack from more than one side the edge distance must be increased to  $c_{min} \geq 300$  mm and  $\geq 2 \cdot h_{ef}$ .

In the absence of other national regulations the partial safety factor for resistance under fire exposure  $\gamma_{M,fi} = 1,0$  is recommended.

**SORMAT PFG anchor LB / SB / ES**

Design according to **CEN/TS 1992-4**  
 Characteristic shear resistance under fire exposure

**Annex C6**

**Table C9: Displacements under tension loads**

SORMAT PFG anchor LB / SB / ES			Anchor size			
			M6	M8	M10	M12
Non-cracked concrete C20/25 - C50/60	N	[kN]	2.0	3.6	4.8	6.3
	$\delta_{N0}$	[mm]	0.1	0.1	0.1	0.1
	$\delta_{N\infty}$	[mm]	0.3	0.3	0.3	0.3

**Table C10: Displacements under shear loads**

SORMAT PFG anchor LB / SB / ES			Anchor size			
			M6	M8	M10	M12
Non-cracked concrete C20/25 - C50/60	V	[kN]	4.6	8.3	13.2	19.2
	$\delta_{V0}$	[mm]	1.5 (+0.7)	1.9 (+1.2)	2.4 (+1.2)	3.3 (+1.2)
	$\delta_{V\infty}$	[mm]	2.3 (+0.7)	2.9 (+1.2)	3.6 (+1.2)	4.9 (+1.2)

Displacement: the table shows the deformation to be expected from the anchor itself, whilst the bracket value indicates the movement between the anchor body and the hole drilled in the concrete member or the hole in the fixture.

<b>SORMAT PFG anchor LB / SB / ES</b>	<b>Annex C7</b>
Design Displacements	