



**Technical and Test Institute
for Construction Prague**
Prosecká 811/76a
190 00 Prague
Czech Republic
eota@tzus.cz



European Technical Assessment **ETA 17/0161**
of 25/04/2020

Technical Assessment Body issuing the ETA:	Technical and Test Institute for Construction Prague
Trade name of the construction product	RAWLPLUG Insulation System R-TFIX-8S
Product family to which the construction product belongs	Product area code: 33 Plastic anchors for fixing of external thermal insulation composite systems with rendering in concrete and masonry
Manufacturer	Rawplug S.A. Ul. Kwidzyńska 6 51-416 Wrocław Poland
Manufacturing plant(s)	Rawplug S.A.
This European Technical Assessment contains	16 pages including 14 Annexes which form an integral part of this assessment.
This European Technical Assessment is issued in accordance with regulation (EU) No 305/2011, on the basis of	EAD 330196-01-0604 Plastic anchors made of virgin or non-virgin material for fixing of external thermal insulation composite systems with rendering
This version replaces	ETA 17/0161 issued on 14/02/2018

Translations of this European Technical Assessment in other languages shall fully correspond to the original issued document and should be identified as such.

Communication of this European Technical Assessment, including transmission by electronic means, shall be in full (excepted the confidential Annex(es) referred to above). However, partial reproduction may be made, with the written consent of the issuing Technical Assessment Body - Technical and Test Institute for Construction Prague. Any partial reproduction has to be identified as such.

1. Technical description of the product

The screwed-in anchor R-TFIX-8S consist of an anchor sleeve with enlarged shaft, an insulation plate made of polypropylene and special screw or overmolded screw made of galvanized steel or stainless steel as expansion element. The expanding part of the anchor sleeve is slotted.

For the surface mounting the anchor may in addition be combined with the anchor plates KWL 090, KWL 110, KWL 140.

For the countersunk mounting the anchor may in addition be combined with the anchor plates KWX 110 or KWX 63.

The anchor is installed in drilled hole by screwing the expansion element into the anchor sleeve.

The illustration and the description of the product are given in Annex A.

2. Specification of the intended use in accordance with the applicable EAD

The performances given in Section 3 are only valid if the anchor is used in compliance with the specifications and conditions given in Annex B.

The provisions made in this European Technical Assessment are based on an assumed working life of the anchor of 25 years. The indications given on the working life cannot be interpreted as a guarantee given by the producer, but are to be regarded only as a means for choosing the products in relation to the expected economically reasonable working life of the works.

3. Performance of the product and references to the methods used for its assessment

3.1 Safety in case of fire (BWR 2)

Not assessed based on EAD 330196-01-0604.

3.2 Safety in use (BWR 4)

Essential characteristic	Performance
Characteristic resistance under tension loads	See Annex C 1
Displacement	See Annex C 1
Plate stiffness	See Annex C 2

3.3 Energy economy and heat retention (BWR 6)

Essential characteristic	Performance
Point thermal transmittance	See Annex C 2

4. Assessment and verification of constancy of performance (AVCP) system applied with reference to its legal base

According to the Decision 97/463/EC of the European Commission¹, the system 2+ of assessment verification of constancy of performance (see Annex V to the Regulation (EU) No 305/2011) apply.

5. Technical details necessary for the implementation of the AVCP system, as provided in the applicable EAD

Technical details necessary for the implementation of the AVCP system are laid down in the control plan deposited at Technical and Test Institute for Construction Prague.

Issued in Prague on 25.04.2020

By

Ing. Mária Schaan

Head of the Technical Assessment Body



¹ Official Journal of the European Communities L 198/31 25.7.1997

R-TFIX-8S

Surface assembly

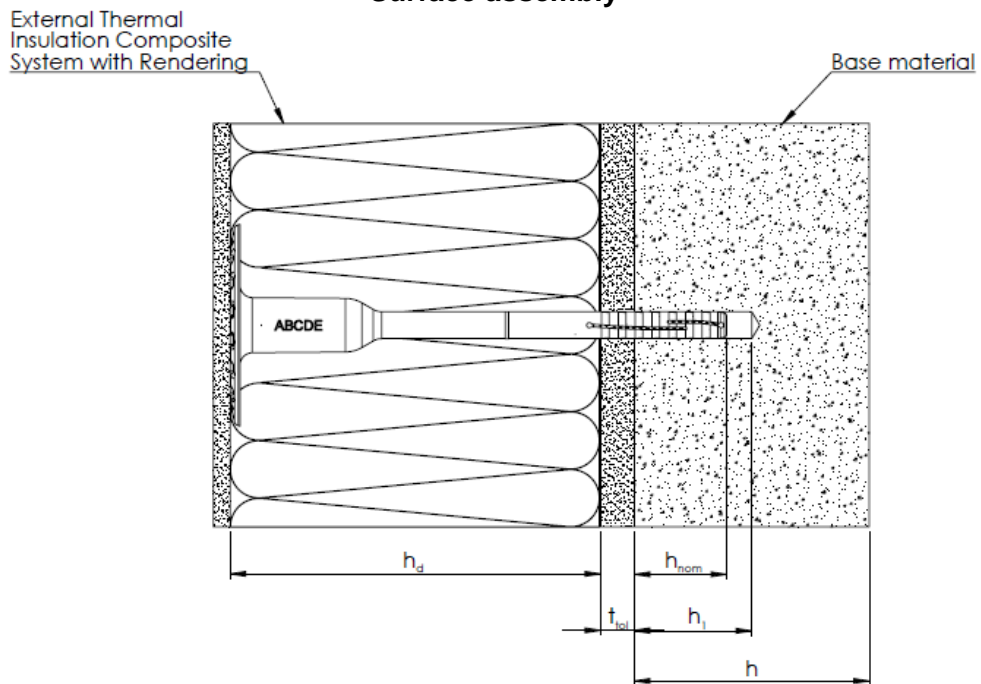

Countersunk assembly

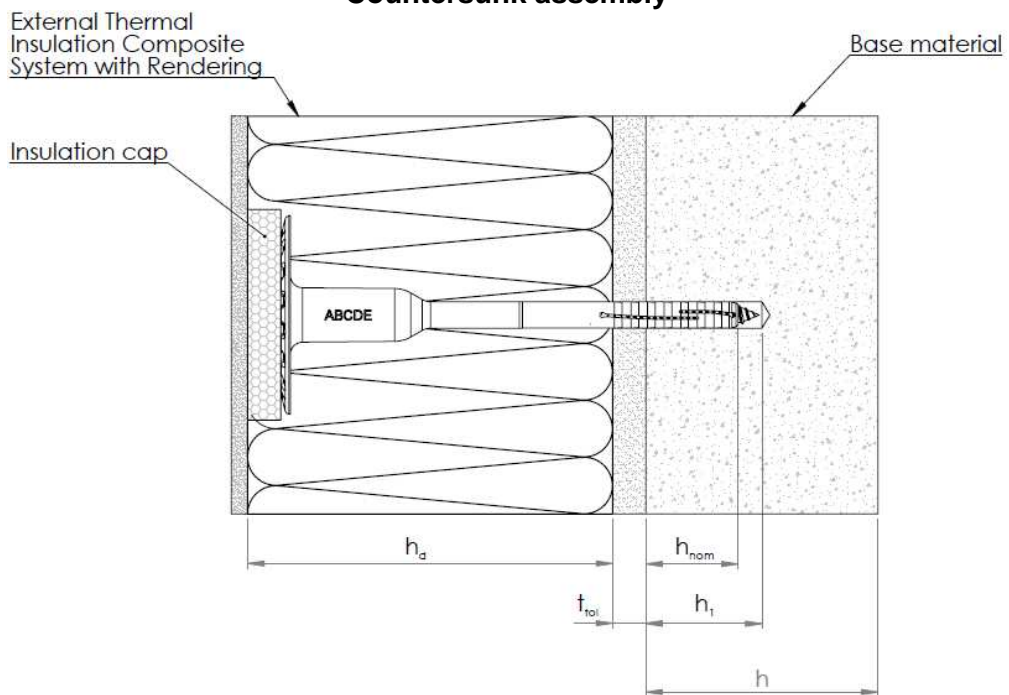

- h_{nom} = overall plastic anchor embedment depth in the base material
- h = thickness of member (wall)
- h_1 = depth of drilled hole to deepest point
- h_d = thickness of insulation material
- t_{tol} = thickness of equalizing layer or non-load-bearing coating

RAWLPLUG Insulation System R-TFIX-8S

Product description
Installed conditions

Annex A 1

**R-TFIX-8S – surface assembly
Anchor sleeve**

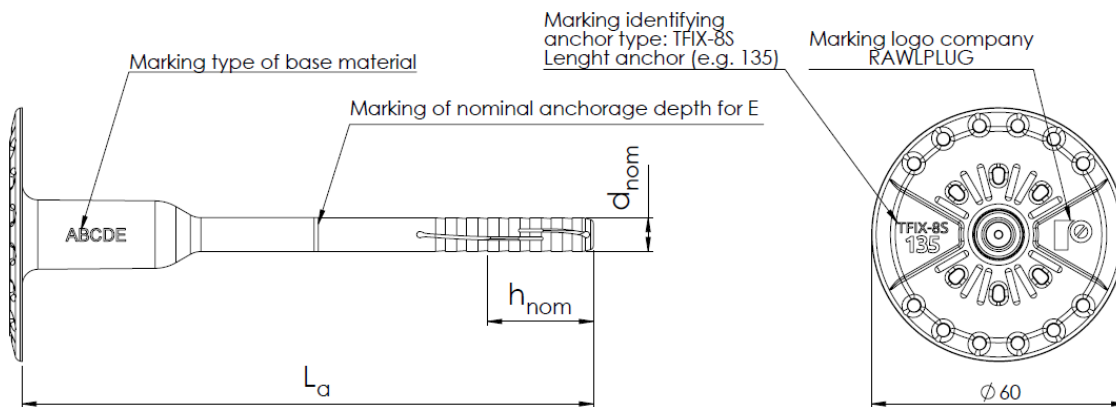

Overmolded screw

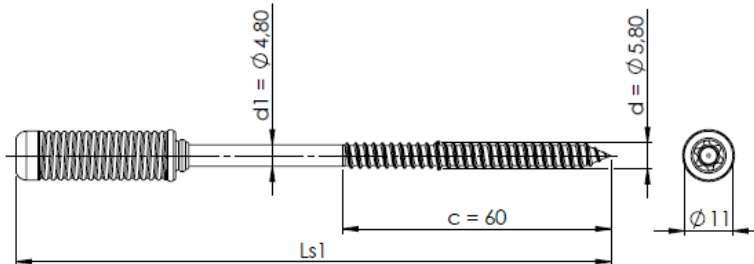

Screw

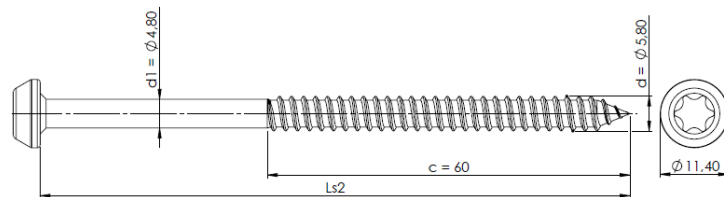

Insulation cap

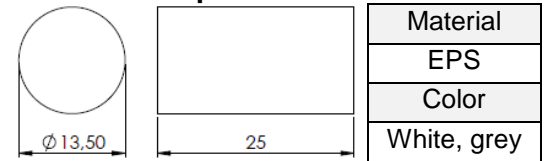

For proper assembly you can use setting tool (Annex B 5) or standard Bit.

Table A1: Dimensions

Anchor type	Anchor sleeve			Screw		
	h _{ef} [mm]		Ød _{nom} [mm]	L _a [mm]	L _{s1} [mm]	L _{s2} [mm]
Use category	A, B, C, D	E				
R-TFIX-8S	25	65	8	135 - 455	115 - 455	80 - 420

Determination of max. thickness of insulation:

$$h_d = L_a - t_{tol} - h_{nom}$$

e.g. L_a = 135 mm, t_{tol} = 10 mm, h_{nom} = 25 mm, h_d = 135 – 10 - 25 = 100 mm

Table A2: Materials of anchor R-TFIX-8S

Designation	Color	Material
Anchor sleeve	Natural, white, red, grey, yellow, black, blue, green, orange	Virgin plastic - Polypropylene
Expansion screw	Natural	Galvanized steel or stainless steel
Overmolded expansion screw	Natural - screw Natural, black, grey - overmolding	Galvanized steel or stainless steel with glass fibre reinforced polyamide overmolding

RAWLPLUG Insulation System R-TFIX-8S

Product description
Dimensions
Materials

Annex A 2

**R-TFIX-8S – countersunk assembly
Anchor sleeve**

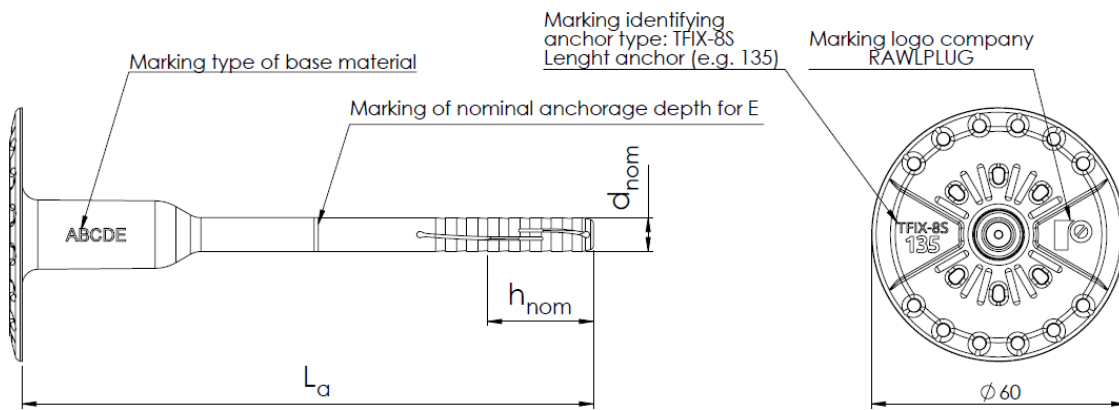

Overmolded screw

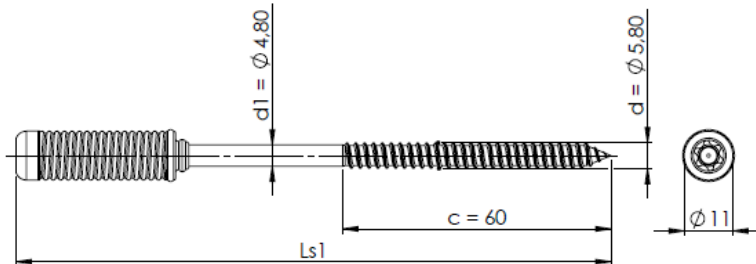

Screw

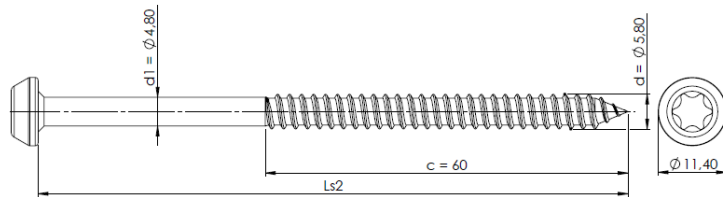

Insulation cap

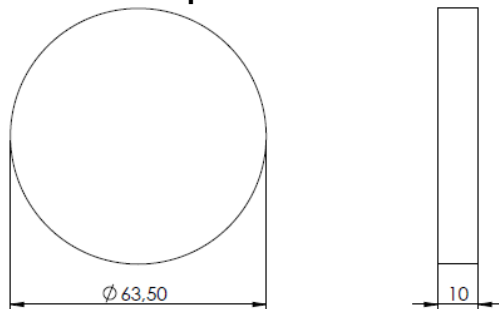

Material	Color
EPS	White, grey
Mineral	Natural

For proper assembly use setting tool (Annex B 5).

Table A3: Dimensions

Anchor type	Anchor sleeve			Screw			
	h_{ef} [mm]		$\varnothing d_{nom}$ [mm]	L_a [mm]	L_1 [mm]	L_2 [mm]	$\varnothing d$ [mm]
Use category	A, B, C, D	E					
R-TFIX-8S	25	65	8	135 - 455	115 - 455	80 - 420	5,8

RAWLPLUG Insulation System R-TFIX-8S

Product description
Dimensions

Annex A 3

Additional plates

KWL 90

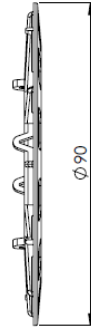
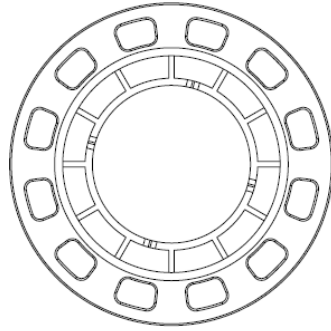

KWL 110

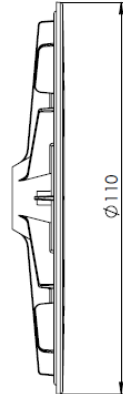
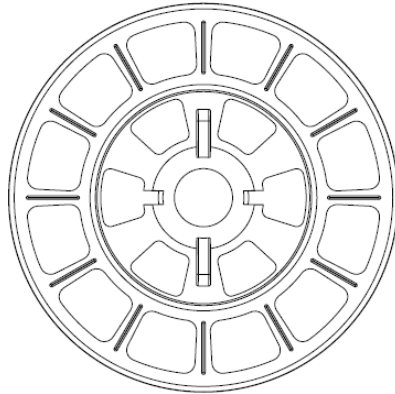

KWL 140

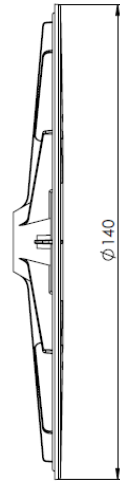
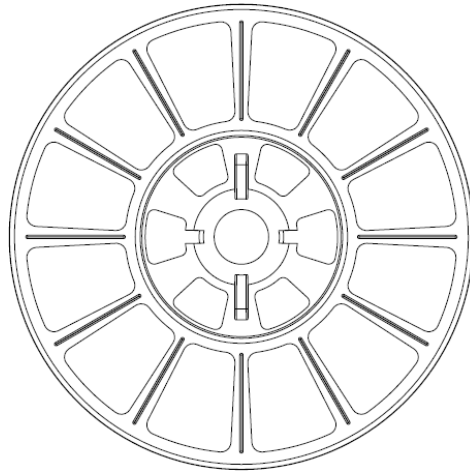

Table A4: Materials of additional plates

Plate	Diameter	Color	Material
KWL 90	90	Natural, white, red, grey, yellow, black, blue, green, orange	Virgin plastic PA6 + GF, PP
KWL 110	110		
KWL 140	140		

RAWLPLUG Insulation System R-TFIX-8S

Product description
Additional plates

Annex A 4

Additional plates

KWX 63

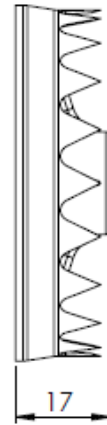
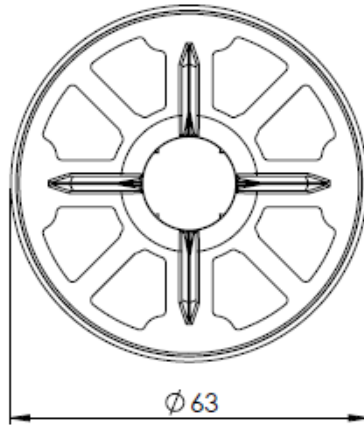

KWX 110

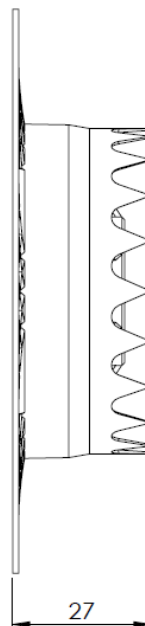
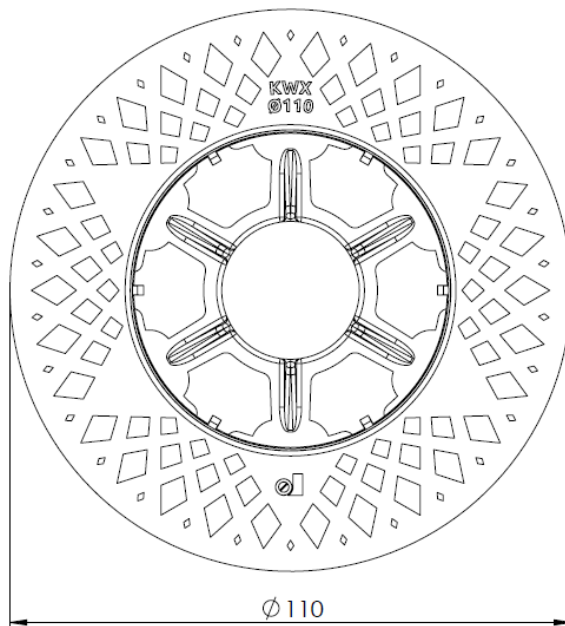

Table A5: Materials of additional plates

Plate	Diameter	Color	Material
KWX 63	63	Natural	Virgin plastic PP+GF; PA+GF
KWX 110	110		

RAWLPLUG Insulation System R-TFIX-8S

Product description
Additional plates

Annex A 5

Specifications of intended use

Anchorage subject to:

- Multiple fixing for the anchorage of bonded thermal insulation composite systems (ETICS).

Base materials

- Reinforced or unreinforced normal weight concrete (Use category A), according to Annex B6.
- Solid brick (Use category B), according to Annex B6.
- Vertically perforated clay bricks POROTHERM 17,5 P+D according to ÖNORM B 6124 (Use category C), according to Annex B6.
- Lightweight aggregate concrete hollow blocks LAC (Use category D), according to Annex B6.
- Autoclaved aerated concrete AAC 4 (Use category E), according to Annex B6.
- The characteristic tension resistance of the anchor may be determined by means of job site tests according to EOTA TR 051, edition December 2016, carried out on the material actually used, if a characteristic resistance of the base material does not exist (for example masonry made of other solid masonry units or made of perforated clay bricks).

Use conditions

- The anchor may only be used for transmission of wind suction loads and shall not be used for the transmission of dead loads of the thermal insulation composite system. The dead loads have to be transmitted by the bonding of the thermal insulation composite system.

Use categories:

- A, B, C, D and E.

Design:

- The design of anchorages is carried out in compliance with EAD 330196-01-0604, " Plastic anchors made of virgin or non-virgin material for fixing of external thermal insulation composite systems with rendering" under the responsibility of an engineer experienced in anchorages.
- Verifiable calculation notes and drawings shall be prepared taking account of the loads to be anchored, the nature and strength of the base materials, the thickness of insulation and the dimensions of the anchorage as well as of the relevant tolerances.
- Proof of direct local application of load on the base material shall be delivered. The anchor shall only be used for the transmission of wind suction loads. All other loads such as dead load and restraints shall be transmitted by the adhesion of the relevant external thermal insulation composite system.

RAWLPLUG Insulation System R-TFIX-8S

Intended use
Specifications

Annex B 1

Installation:

The fitness for use of the anchor can only be assumed if the following conditions of installation are met:

- Anchor installation carried out by appropriately qualified personnel under the supervision of the person responsible for technical matters on site.
- Observation of the drill method (Drill holes in masonry made of vertically perforated clay bricks, lightweight aggregate concrete hollow blocks (LAC) and autoclaved aerated concrete may only be drilled using the rotary drill. Other drilling methods may also be used if job-site tests evaluate the influence of hammer or impact drilling.)
- Placing drill holes without damaging the reinforcement
- Temperature during installation of the anchor $\geq 0^{\circ}\text{C}$.
- Exposure to UV due to solar radiation of the anchor not protected by rendering 6 weeks.

Installation instructions – surface assembly

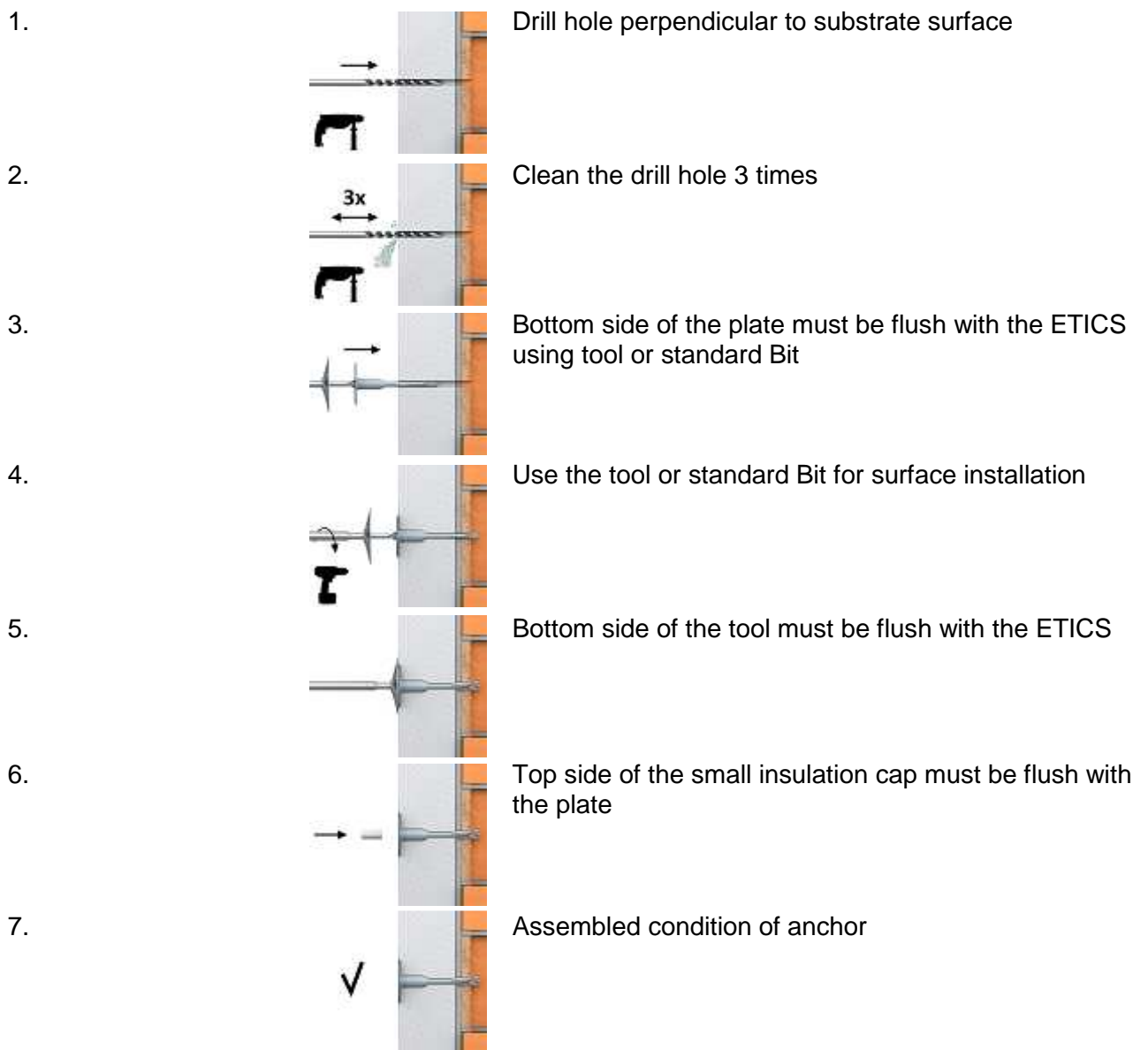

RAWLPLUG Insulation System R-TFIX-8S		Annex B 2
Intended use		
Installation Installation instructions – surface assembly		

Installation instructions – countersunk assembly with R-TFIX – 8CS TOOL

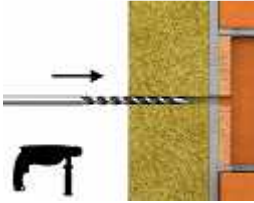
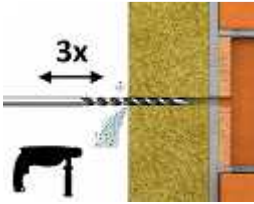
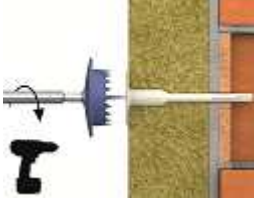
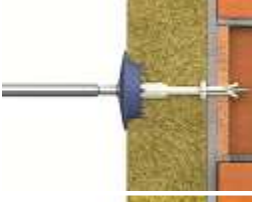
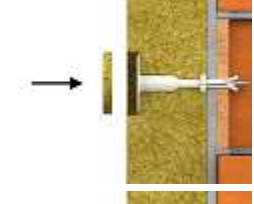
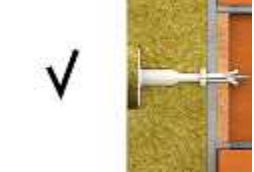
1.  Drill hole perpendicular to substrate surface
2.  Clean the drill hole 3 times
3.  Bottom side of the plate must be flush with the ETICS using tool
4.  Use the tool for countersunk assembly. Bottom side of the tool must be flush with the ETICS
5.  Top side of the insulation cap must be flush with the ETICS
6.  Assembled condition of anchor

RAWLPLUG Insulation System R-TFIX-8S

Intended use
Installation instructions – countersunk assembly

Annex B 3

Installation instructions – countersunk assembly R-TFIX-CSM TOOL

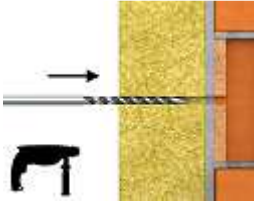
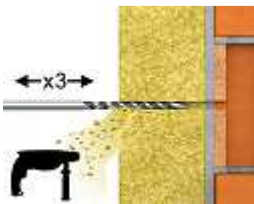
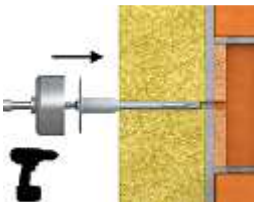
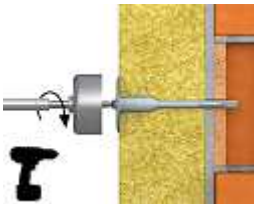
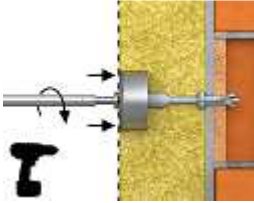
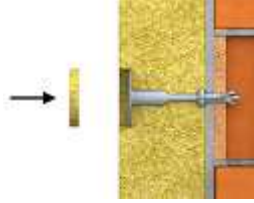
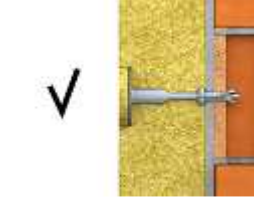
1.  Drill hole perpendicular to substrate surface
2.  Clean the drill hole 3 times
3.  Bottom side of the plate must be flush with the ETICS using tool
4.  Use the tool for countersunk assembly
5.  Bottom side of the tool must be flush with the ETICS
6.  Top side of the insulation cap must be flush with the ETICS
7.  Assembled condition of anchor

RAWLPLUG Insulation System R-TFIX-8S

Intended use
Installation instructions – countersunk assembly

Annex B 4

Setting tool

R-TFIX - 8S TOOL for surface assembly

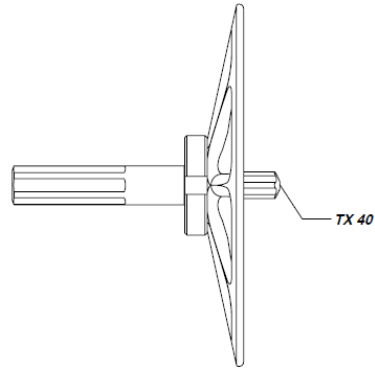
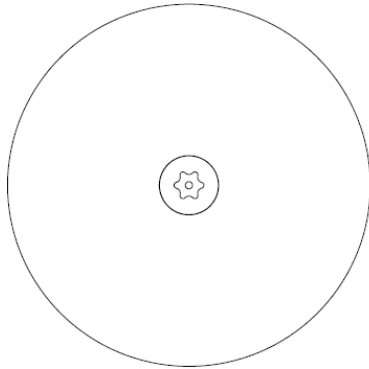

TX 40 = TORX ® 40 Bit

R-TFIX – 8CS TOOL for countersunk assembly

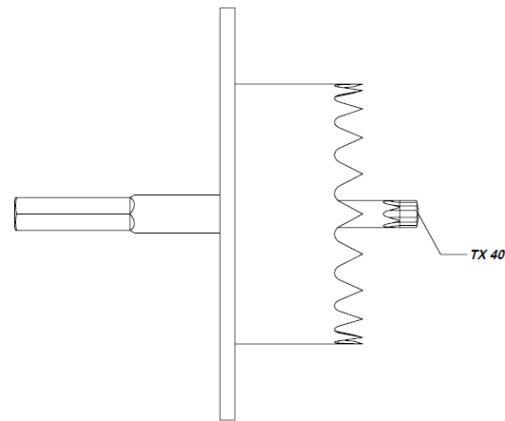
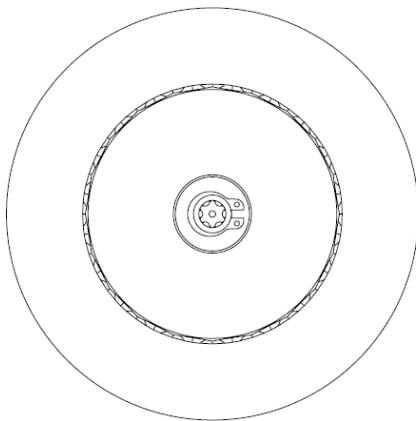

TX 40 = TORX ® 40 Bit

R-TFIX-TOOL-CSM TOOL for countersunk assembly

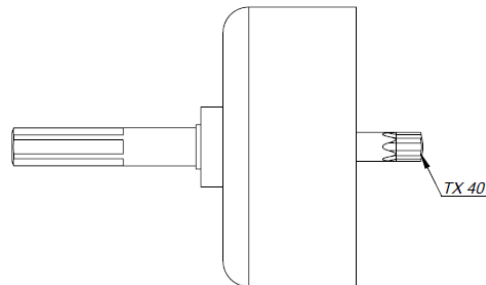
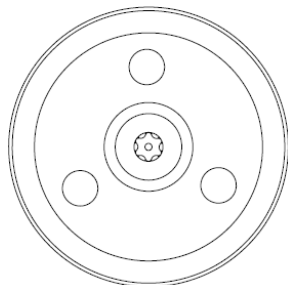

TX 40 = TORX ® 40 Bit

RAWLPLUG Insulation System R-TFIX-8S

Intended use
Setting tool

Annex B 5

Types of base materials

Table B1: Base materials

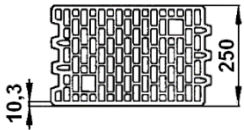
Base material	Use category	Bulk density [kg/dm ³]	Min. compressive strength f _c [N/mm ²]	General remarks	Drilling method
Concrete C 12/15 according to EN 206-1	A				Hammer drilling
Concrete C 16/20 – C 50/60 according to EN 206-1	A				Hammer drilling
External wall panel of concrete C 16/20 – C50/60 according to EN 206-1	A			Minimum thickness ≥ 40 mm	Hammer drilling or rotary drilling
Solid clay bricks according to EN 771-1	B	≥ 1,7	20	Vertically perforation up to 15%	Hammer drilling
Solid sand-lime bricks according to EN 771-2	B	≥ 1,8	30	Vertically perforation up to 15%	Hammer drilling
Vertically perforated clay bricks POROTHERM 17,5 P+D according to ÖNORM B 6124	C	≥ 0,9	15		Only rotary drilling
Lightweight aggregate concrete hollow blocks LAC according to EN 1520	D	≥ 1,2	4		Only rotary drilling
Autoclaved aerated concrete AAC 4 according to EN 771-4	E	≥ 0,4	4		Only rotary drilling

RAWLPLUG Insulation System R-TFIX-8S

Intended use
Base materials

Annex B 6

Installation

Table B2: Installation characteristics

Anchor type		R-TFIX-8S	
Use category		A, B, C, D	E
Nominal diameter of drill bit	d_o [mm]	8	8
Min. diameter of drill bit	$d_{cut, min} \geq$ [mm]	8,2	8,2
Max. diameter of drill bit	$d_{cut, max} \leq$ [mm]	8,45	8,45
Depth of drill hole - Surface assembly	$h_1 \geq$ [mm]	35	75
Depth of drill hole - Countersunk assembly	$h_1 \geq$ [mm]	45	85
Effective embedment depth	$h_{ef} \geq$ [mm]	25	65

Table B3.1: Minimum thickness of base material, edge distance and anchor spacing

Anchor type	Minimum thickness of base material h [mm]	Minimum spacing s_{min} [mm]	Minimum edge distance c_{min} [mm]
R-TFIX-8S	100	100	100

Table B3.2: Minimum thickness of external wall panel of concrete, edge distance and anchor spacing

Anchor type	Minimum thickness of base material h [mm]	Minimum spacing s_{min} [mm]	Minimum edge distance c_{min} [mm]
R-TFIX-8S	40	100	100

Scheme of distance and spacing.

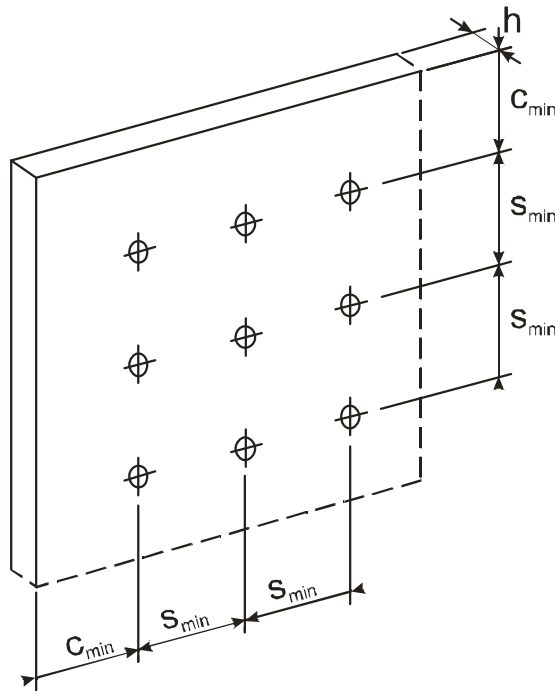

RAWLPLUG Insulation System R-TFIX-8S

Intended use
Installation characteristics
Edge and axial distances

Annex B 7

Table C1: Characteristic resistance to tension loads for single anchor

Base material	Use category	Bulk density [kg/dm ³]	Min. compressive strength β [N/mm ²]	R-TFIX-8S [kN]
Concrete C 12/15 according to EN 206-1	A			1,2
Concrete C 16/20 – C 50/60 according to EN 206-1	A			1,5
External wall panel of concrete C 16/20 – C50/60 according to EN 206-1	A			1,5
Solid clay bricks according to EN 771-1	B	$\geq 1,7$	20	1,5
Solid sand-lime bricks according to EN 771-2	B	$\geq 1,8$	30	1,5
Vertically perforated clay bricks POROTHERM 17,5 P+D according to ÖNORM B6124	C	$\geq 0,9$	15	0,9
Lightweight aggregate concrete hollow blocks LAC according to EN 1520	D	$\geq 1,2$	4	0,9
Autoclaved aerated concrete AAC 4 according to EN 771-4	E	$\geq 0,4$	4	1,2
Partial safety factor	$\gamma_M^{1)}$	2,0		

¹⁾in the absence of other national regulations

Table C2: Displacement of anchors R-TFIX-8S under tension loads

Base material	Tension load N_{Sk} [kN]	Displacement $\Delta\delta_N$ [mm]
Concrete C 12/15 according to EN 206-1	0,5	0,80
Concrete C 16/20 – C 50/60 according to EN 206-1	0,5	0,80
External wall panel of concrete C 16/20 – C50/60 according to EN 206-1	0,5	0,80
Solid clay bricks according to EN 771-1	0,5	0,74
Solid sand-lime bricks according to EN 771-2	0,5	0,67
Vertically perforated clay bricks POROTHERM 17,5 P+D according to ÖNORM B 6124	0,3	0,63
Lightweight aggregate concrete hollow blocks LAC according to EN 1520	0,3	0,70
Autoclaved aerated concrete AAC 4 according to EN 771-4	0,4	0,79

RAWLPLUG Insulation System R-TFIX-8S**Performances**

Characteristic tension load
Displacement under tension load

Annex C 1

Table C3: Plate stiffness

Anchor type	Diameter of the anchor plate [mm]	Load resistance of the anchor plate [kN]	Plate stiffness [kN/mm]
R-TFIX-8S	60	2,04	0,6

Table C4: Point thermal transmittance

Anchor type	Insulation thickness h_D [mm]	Point thermal transmittance χ [W/K]
R-TFIX-8S Surface assembly	60 – 420	0,002
R-TFIX-8S Countersunk assembly	60 – 100	0,001
R-TFIX-8S Countersunk assembly	120 – 420	0,002

RAWLPLUG Insulation System R-TFIX-8S**Performances**

Plate stiffness

Point thermal transmittance

Annex C 2