



# HILTI HIT-HY 270 INJECTION MORTAR

ETA-19/0160 (30.08.2019)



<a href="#">English</a>	2-52
<a href="#">Deutsch</a>	54-104
<a href="#">Polski</a>	106-157

Approval body for construction products  
and types of construction

Bautechnisches Prüfamt

An institution established by the Federal and  
Laender Governments



## European Technical Assessment

ETA-19/0160  
of 30 August 2019

English translation prepared by DIBt - Original version in German language

### General Part

Technical Assessment Body issuing the  
European Technical Assessment:

Deutsches Institut für Bautechnik

Trade name of the construction product

Hilti HIT-HY 270 with HAS-U

Product family  
to which the construction product belongs

Metal Injection anchors for use in masonry

Manufacturer

Hilti Aktiengesellschaft  
9494 SCHAAN  
FÜRSTENTUM LIECHTENSTEIN

Manufacturing plant

Hilti Werke

This European Technical Assessment  
contains

51 pages including 3 annexes which form an integral part  
of this assessment

This European Technical Assessment is  
issued in accordance with Regulation (EU)  
No 305/2011, on the basis of

EAD 330076-00-0604

This version replaces

ETA-19/0160 issued on 29 April 2019

The European Technical Assessment is issued by the Technical Assessment Body in its official language. Translations of this European Technical Assessment in other languages shall fully correspond to the original issued document and shall be identified as such.

Communication of this European Technical Assessment, including transmission by electronic means, shall be in full. However, partial reproduction may only be made with the written consent of the issuing Technical Assessment Body. Any partial reproduction shall be identified as such.

This European Technical Assessment may be withdrawn by the issuing Technical Assessment Body, in particular pursuant to information by the Commission in accordance with Article 25(3) of Regulation (EU) No 305/2011.

## Specific Part

### 1 Technical description of the product

The Injection system Hilti HIT-HY 270 with HAS-U for masonry is a bonded anchor (injection type) consisting of a mortar foil pack with injection mortar Hilti HIT-HY 270, a perforated sieve sleeve and an anchor rod with hexagon nut and washer in the range of M6 to M16. The steel elements are made of zinc coated steel, stainless steel or high corrosion resistant steel.

The anchor rod is placed into a drilled hole filled with injection mortar and is anchored via the bond and/or mechanical interlock between steel element, injection mortar and masonry.

The product description is given in Annex A.

### 2 Specification of the intended use in accordance with the applicable European Assessment Document

The performances given in Section 3 are only valid if the anchor is used in compliance with the specifications and conditions given in Annex B.

The verifications and assessment methods on which this European Technical Assessment is based lead to the assumption of a working life of the anchor of at least 50 years. The indications given on the working life cannot be interpreted as a guarantee given by the producer, but are to be regarded only as a means for choosing the right products in relation to the expected economically reasonable working life of the works.

### 3 Performance of the product and references to the methods used for its assessment

#### 3.1 Mechanical resistance and stability (BWR 1)

Essential characteristic	Performance
Characteristic values for resistance	See Annexes C1 to C30
Displacements	See Annex C4 to C30
Durability	See Annex B2

#### 3.2 Safety in case of fire (BWR 2)

Essential characteristic	Performance
Reaction to fire	Class A1

#### 3.3 Hygiene, health and the environment (BWR 3)

Essential characteristic	Performance
Content, emission and/or release of dangerous substances	No performance assessed

### 4 Assessment and verification of constancy of performance (AVCP) system applied, with reference to its legal base

In accordance with the European Assessment Document EAD 330076-00-0604 the applicable European legal act is: [97/177/EC].

The system to be applied is: 1

**5 Technical details necessary for the implementation of the AVCP system, as provided for in the applicable European Assessment Document**

Technical details necessary for the implementation of the AVCP system are laid down in the control plan deposited at Deutsches Institut für Bautechnik.

Issued in Berlin on 30 August 2019 by Deutsches Institut für Bautechnik

BD Dipl.-Ing. Andreas Kummerow  
Head of Department

*beglaubigt:*  
Lange

**Installed condition**

**Figure A1:** Hollow and solid brick with HAS-U-... and one sieve sleeve HIT-SC (see Table B5)

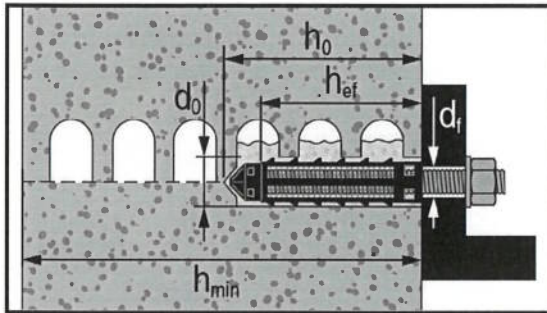

**Figure A2:** Hollow and solid brick with HAS-U-... and two sieve sleeves HIT-SC for deeper embedment depth (see Table B6)

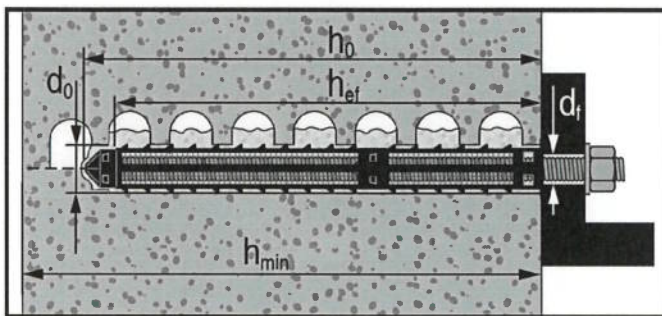

**Figure A3:** Solid brick with HAS-U-... (see Table B7)

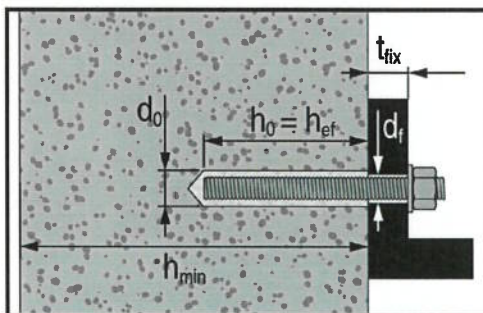

Hilti HIT-HY 270 with HAS-U

Product description  
Installed condition

Annex A1

**Figure A4: Hollow and solid brick with HAS-U-... with two sieve sleeves HIT-SC for setting through the fixture and/or through the non-loadbearing layer (see Table B8)**

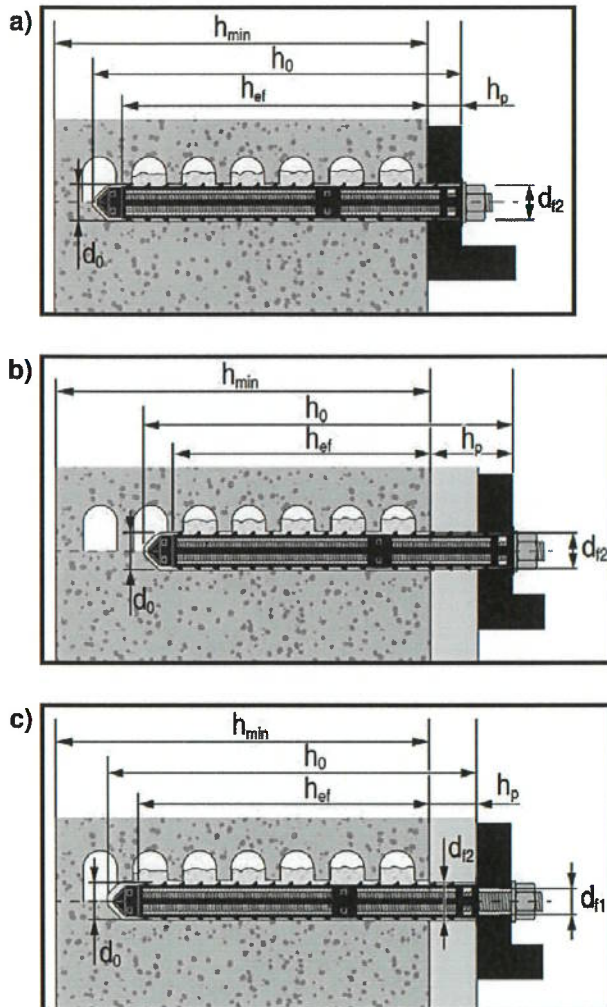

Hilti HIT-HY 270 with HAS-U

Product description  
Installed condition

Annex A2

English translation prepared by DIBt

**Product description: Injection mortar and steel elements**

**Injection mortar Hilti HIT-HY 270:** hybrid system with aggregate  
330 ml and 500 ml

Marking

HILTI HY-270  
Production number and  
production line  
Expiry date mm/yyyy



Product name: "Hilti HIT-HY 270"

**Static mixer Hilti HIT-RE-M**



**HAS-U-...**

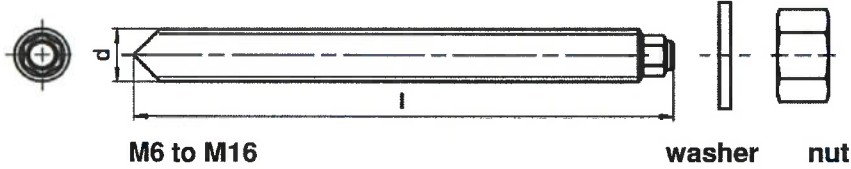

**Sieve sleeve HIT-SC 16 to 22**



**Hilti HIT-HY 270 with HAS-U**

**Product description**  
Injection mortar / Static mixer / Steel element / Sieve sleeve

**Annex A3**



**Table A1: Materials**

Designation	Material
<b>Metal parts made of zinc coated steel</b>	
HAS-U-5.8 (HDG)	Strength class 5.8, $f_{uk} = 500 \text{ N/mm}^2$ , $f_{yk} = 400 \text{ N/mm}^2$ , Rupture elongation ( $l_0 = 5d$ ) > 8% ductile Electroplated zinc coated $\geq 5 \mu\text{m}$ , (HDG) Hot dip galvanized $\geq 45 \mu\text{m}$
HAS-U-8.8 (HDG)	Strength class 8.8, $f_{uk} = 800 \text{ N/mm}^2$ , $f_{yk} = 640 \text{ N/mm}^2$ , Rupture elongation ( $l_0 = 5d$ ) > 12% ductile Electroplated zinc coated $\geq 5 \mu\text{m}$ , (HDG) Hot dip galvanized $\geq 45 \mu\text{m}$
Washer	Electroplated zinc coated $\geq 5 \mu\text{m}$ Hot dip galvanized $\geq 45 \mu\text{m}$
Nut	Strength class of nut adapted to strength class of threaded rod Electroplated zinc coated $\geq 5 \mu\text{m}$ , Hot dip galvanized $\geq 45 \mu\text{m}$
<b>Metal parts made of stainless steel</b>	
HAS-U A4	Strength class 70 $f_{uk} = 700 \text{ N/mm}^2$ , $f_{yk} = 450 \text{ N/mm}^2$ , Rupture elongation ( $l_0 = 5d$ ) > 8% ductile Stainless steel A4 according to EN 10088-1: 2014
Washer	Stainless steel A4 according to EN 10088-1: 2014
Nut	Strength class of nut adapted to strength class of threaded rod Stainless steel A4 according to EN 10088-1: 2014
<b>Metal parts made of high corrosion resistant steel</b>	
HAS-U HCR	$f_{uk} = 800 \text{ N/mm}^2$ , $f_{yk} = 640 \text{ N/mm}^2$ , Rupture elongation ( $l_0 = 5d$ ) > 8% ductile High corrosion resistant steel according to EN 10088-1: 2014
Washer	High corrosion resistant steel according to EN 10088-1: 2014
Nut	Strength class of nut adapted to strength class of threaded rod High corrosion resistant steel according to EN 10088-1: 2014
<b>Plastic parts</b>	
Sieve sleeve HIT-SC	Frame: FPP 20T Sieve: PA6.6 N500/200

**Hilti HIT-HY 270 with HAS-U**

**Product description**  
Materials

**Annex A4**

## Specifications of intended use

### Base materials:

- Solid brick masonry (use category b), according to Annex B3.  
Note: The characteristic resistances are also valid for larger brick sizes and larger compressive strengths of the masonry unit.
- Hollow brick masonry (use category c), according to Annex B3 and B5.
- Mortar strength class of the masonry: M2,5 at minimum according to EN 998-2: 2010.
- For masonry made of other solid, hollow or perforated bricks, the characteristic resistance of the anchor may be determined by job site tests according to TR 053, April 2016 under consideration of the  $\beta$ -factor according to Annex C1, Table C1.

**Table B1: Overview use categories**

Anchorages subject to:		HIT-HY 270 with HAS-U	
		In solid bricks	In hollow bricks
Hole drilling		Hammer mode, Rotary mode	Rotary mode
Static and quasi static loading		Annex : C1 (steel), C3 to C20	Annex : C1 (steel), C21 to C30
Use category: dry or wet structure		Category <b>d/d</b> - <b>Installation and use</b> in structures subject to <b>dry</b> internal conditions. Category <b>w/d</b> - <b>Installation in dry or wet substrate and use</b> in structures subject to <b>dry</b> internal conditions (except calcium silicate bricks). Category <b>w/w</b> - <b>Installation and use</b> in structures subject to <b>dry or wet</b> environmental conditions (except calcium silicate bricks).	
Installation direction Masonry		Horizontal	
Installation direction Ceiling brick		Overhead	
Use category		b (solid masonry)	c (hollow or perforated masonry)
Temperature in the base material at installation		+5° C to +40° C (Table B9)	0° C to +40° C (Table B10)
In-service temperature	Temperature range Ta:	-40 °C to +40 °C	(max. long term temperature +24 °C and max. short term temperature +40 °C)
	Temperature range Tb:	-40 °C to +80 °C	(max. long term temperature +50 °C and max. short term temperature +80 °C)

**Hilti HIT-HY 270 with HAS-U**

**Intended Use  
Specifications**

**Annex B1**

**Use conditions (Environmental conditions):**

- Structures subject to dry internal conditions (zinc coated steel, stainless steel or high corrosion resistant steel).
- Structures subject to external atmospheric exposure (including industrial and marine environment) and to permanently damp internal conditions, if no particular aggressive conditions exist (stainless steel or high corrosion resistant steel).
- Structures subject to external atmospheric exposure and to permanently damp internal conditions, if other particular aggressive conditions exist (high corrosion resistant steel).

Note: Particular aggressive conditions are e.g. permanent, alternating immersion in seawater or the splash zone of seawater, chloride atmosphere of indoor swimming pools or atmosphere with extreme chemical pollution (e.g. in desulphurization plants or road tunnels where de-icing products are used).

**Design:**

- Anchorages are designed under the responsibility of an engineer experienced in anchorages and masonry work.
- Verifiable calculation notes and drawings are prepared taking account of the loads to be anchored. The position of the anchor is indicated on the design drawings (e. g. position of the anchor relative to supports, etc.).
- Anchorages under static or quasi-static loading are designed in accordance with: TR 054, April 2016 Design method A.
- In case of a brick compressive strength  $f_b$  is smaller than the highest strength stated in the load table the load can be calculated according to the following Equation:

$$F_{Rk,act.} = F_{Rk,ETA,(fb)} * (f_{b,act.}/f_{b,ETA})^\alpha$$

$F_{Rk,act.}$  = Resistance of the fastener in the actual masonry unit

$F_{Rk,ETA,(fb)}$  = Resistance of the fastener in the masonry unit stated in annex C3 to C30

$f_{b,act.}$  = Actual normalized mean compressive strength of the masonry unit according to EN 772-1:2011

$f_{b,ETA.}$  = Normalized mean compressive strength stated in annexes C3 to C30

$\alpha$  = 0,5 for masonry units of clay or concrete and solid unit of calcium silicate

$\alpha$  = 0,75 for masonry units of perforated calcium silicate

- For hollow brick masonry. The shear load vertical to the free edge must be transferred via the vertical joint. (Completely filled joint or direct contact.)
- For hollow brick masonry shear load only without lever arm permitted.

**Installation:**

- Anchor installation carried out by appropriately qualified personnel and under the supervision of the person responsible for technical matters of the site.

Hilti HIT-HY 270 with HAS-U

Intended Use  
Specifications

Annex B2

**Table B2: Overview brick types and properties**

Brick type	Picture	Brick size [mm]	Compressive strength $f_{b,ETA}$ [N/mm <sup>2</sup> ]	Bulk density [kg/dm <sup>3</sup> ]	Annex
Solid clay brick EN 771-1		≥ 240x115x52	12 / 20 / 40	2,0	C3/C4
Solid clay brick EN 771-1		≥ 240x115x72	10 / 20	2,0	C5/C7
Solid clay brick EN 771-1		≥ 240x115x113	12 / 20	2,0	C8/C10
Solid calcium silicate brick EN 771-2		≥ 240x115x113	12 / 28	2,0	C11/C12
Solid calcium silicate brick EN 771-2		≥ 248x240x248	12 / 20 / 28	2,0	C13/C16
Solid light weight concrete brick EN 771-3		≥ 240x115x113	4 / 6	0,9	C17/C18
Solid normal weight concrete brick EN 771-3		≥ 240x115x113	6 / 16	2,0	C19/C20
Hollow clay brick EN 771-1		300x240x238	12 / 20	1,4	C21/C22
Hollow calcium silicate brick EN 771-2		248x240x248	12 / 20	1,4	C23/C24
Hollow lightweight concrete brick EN 771-3		495x240x238	2 / 6	0,7	C25/C27
Hollow normal weight concrete brick EN 771-3		500x200x200	4 / 10	0,9	C28/C29
Hollow clay brick EN 771-1 Ceiling brick		250x510x180	DIN EN 15037-3 class R2	1,0	C30

**Hilti HIT-HY 270 with HAS-U**

**Intended Use**  
Brick types and properties

**Annex B3**

**Table B3: Overview fastening elements (including sizes and embedment depths) and corresponding brick types**







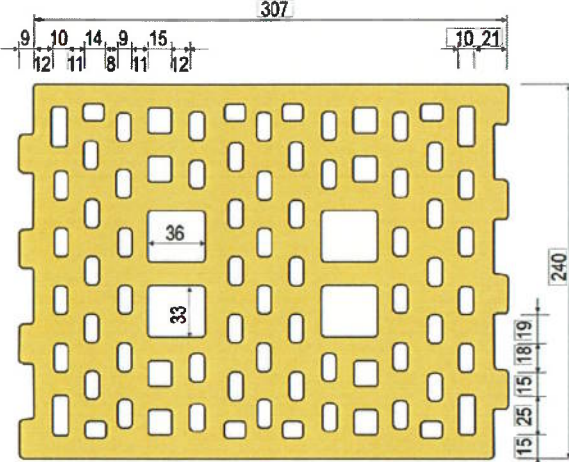

Brick type	Picture	HAS-U 	HAS-U + HIT-SC 	Annex
Solid clay brick EN 771-1		M8 to M16 $h_{ef} = 50 \text{ mm}$ to 300 mm	M8 to M16 $h_{ef} = 80 \text{ mm}$ to 160 mm	C3/C4
Solid clay brick EN 771-1		M8 to M16 $h_{ef} = 50 \text{ mm}$ to 300 mm	M8 to M16 $h_{ef} = 80 \text{ mm}$ to 160 mm	C5/C7
Solid clay brick EN 771-1		M8 to M16 $h_{ef} = 50 \text{ mm}$ to 300 mm	M8 to M16 $h_{ef} = 80 \text{ mm}$ to 160 mm	C8/C10
Solid calcium silicate brick EN 771-2		M8 to M16 $h_{ef} = 50 \text{ mm}$ to 300 mm	M8 to M16 $h_{ef} = 80 \text{ mm}$ to 160 mm	C11/C12
Solid calcium silicate brick EN 771-2		M8 to M16 $h_{ef} = 50 \text{ mm}$ to 300 mm	M8 to M16 $h_{ef} = 80 \text{ mm}$ to 160 mm	C13/C16
Solid light weight concrete brick EN 771-3		M8 to M16 $h_{ef} = 50 \text{ mm}$ to 300 mm	M8 to M16 $h_{ef} = 80 \text{ mm}$ to 160 mm	C17/C18
Solid normal weight concrete brick EN 771-3		M8 to M16 $h_{ef} = 50 \text{ mm}$ to 300 mm	M8 to M16 $h_{ef} = 80 \text{ mm}$ to 160 mm	C19/C20
Hollow clay brick EN 771-1		-	M8 to M16 $h_{ef} = 80 \text{ mm}$ to 160 mm	C21/C22
Hollow calcium silicate brick EN 771-2		-	M8 to M16 $h_{ef} = 80 \text{ mm}$ to 160 mm	C23/C24
Hollow lightweight concrete brick EN 771-3		-	M8 to M16 $h_{ef} = 80 \text{ mm}$ to 160 mm	C25/C27
Hollow normal weight concrete brick EN 771-3		-	M8 to M16 $h_{ef} = 50 \text{ mm}$ to 160 mm	C28/C29
Hollow clay brick EN 771-1 Ceiling brick		-	M6 $h_{ef} = 80 \text{ mm}$	C30

Hilti HIT-HY 270 with HAS-U

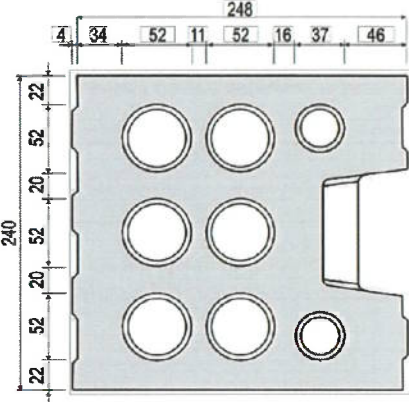
Intended Use  
Fastening elements and corresponding brick types

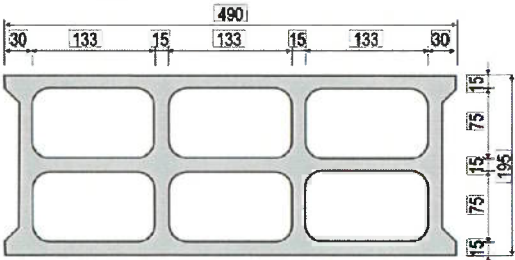
Annex B4

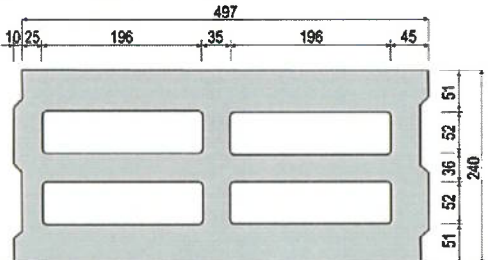
**Table B4: Details of hollow bricks**

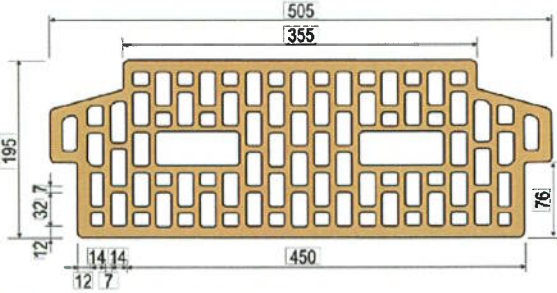

<p>Hollow clay brick EN 771-1</p> <p>Rapis Ziegel Hlz 12-1,4-10DF</p>  	<p>Hollow calcium silicate brick EN 771-2</p> <p>KS Wemding KSL-R(P) 12-1,4 8DF</p>  
<p>Hollow normal weight concrete brick EN 771-3</p> <p>Parpaing creux B40</p>  	<p>Hollow lightweight concrete brick EN 771-3</p> <p>Knobel Betonwerk Hbl 4-0,8-500x240x238</p>  
	<p>Hollow clay brick EN 771-1</p> <p>Ceiling brick Fiedler Brick Ceiling Type 18+0 or 18+3</p>  

Hilti HIT-HY 270 with HAS-U

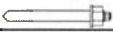

Intended Use  
Details of hollow bricks

Annex B5

**Table B5: Installation parameters of HAS-U-... with one sieve sleeve HIT-SC in hollow brick and solid brick (Figure A1)**

HAS-U-...		M6	M8		M10		M12		M16	
with HIT-SC		12x85	16x50	16x85	16x50	16x85	18x50	18x85	22x50	22x85
Nominal diameter of drill bit	$d_0$ [mm]	12	16	16	16	16	18	18	22	22
Drill hole depth	$h_0$ [mm]	95	60	95	60	95	60	95	60	95
Effective embedment depth	$h_{ef}$ [mm]	80	50	80	50	80	50	80	50	80
Maximum diameter of clearance hole in the fixture	$d_f$ [mm]	7	9	9	12	12	14	14	18	18
Minimum wall thickness	$h_{min}$ [mm]	115	80	115	80	115	80	115	80	115
Brush HIT-RB	- [-]	12	16	16	16	16	18	18	22	22
Number of strokes HDM	- [-]	5	4	6	4	6	4	8	6	10
Number of strokes HDE 500-A	- [-]	4	3	5	3	5	3	6	5	8
Maximum torque moment for all brick types except "parpaing creux"	$T_{max}$ [Nm]	0	3	3	4	4	6	6	8	8
Maximum torque moment for "parpaing creux"	$T_{max}$ [Nm]	-	2	2	2	2	3	3	6	6

**Table B6: Installation parameters of HAS-U-... with two HIT-SC in hollow brick and solid brick for deeper embedment depth (Figure A2)**

HAS-U-...		M8		M10	
with HIT-SC		16x50+16x85	16x85+16x85	16x50+16x85	16x85+16x85
Nominal diameter of drill bit	$d_0$ [mm]	16		16	
Drill hole depth	$h_0$ [mm]	145		180	
Effective embedment depth	$h_{ef}$ [mm]	130		160	
Maximum diameter of clearance hole in the fixture	$d_f$ [mm]	9		12	
Minimum wall thickness	$h_{min}$ [mm]	195		230	
Brush HIT-RB	- [-]	16		16	
Number of strokes HDM	- [-]	4+6		6+6	
Number of strokes HDE-500	- [-]	3+5		5+5	
Maximum torque moment	$T_{max}$ [Nm]	3		4	

**Table B6 continued**

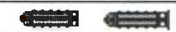
HAS-U-...		M12		M16	
with HIT-SC		18x50+18x85	18x85+18x85	22x50+22x85	22x85+22x85
Nominal diameter of drill bit	$d_0$ [mm]	18		22	
Drill hole depth	$h_0$ [mm]	145		180	
Effective embedment depth	$h_{ef}$ [mm]	130		160	
Maximum diameter of clearance hole in the fixture	$d_f$ [mm]	14		18	
Minimum wall thickness	$h_{min}$ [mm]	195		230	
Brush HIT-RB	- [-]	18		22	
Number of strokes HDM	- [-]	4+8		6+10	
Number of strokes HDE-500	- [-]	3+6		5+8	
Maximum torque moment	$T_{max}$ [Nm]	6		8	

Hilti HIT-HY 270 with HAS-U

Intended Use  
Installation parameters

Annex B6

**Table B7: Installation parameters of HAS-U-... in solid brick (Figure A3)**

HAS-U-...			M8	M10	M12	M16
Nominal diameter of drill bit	$d_0$	[mm]	10	12	14	18
Drill hole depth = Effective embedment depth	$h_0 =$ $h_{ef}$	[mm]	50...300	50...300	50...300	50...300
Maximum diameter of clearance hole in the fixture	$d_f$	[mm]	9	12	14	18
Minimum wall thickness	$h_{min}$	[mm]	$h_0+30$	$h_0+30$	$h_0+30$	$h_0+36$
Brush HIT-RB	-	[-]	10	12	14	18
Maximum torque moment	$T_{max}$	[Nm]	5	8	10	10



Hilti HIT-HY 270 with HAS-U

Intended Use  
Installation parameters



Annex B7



**Table B8: Installation parameters of HAS-U-... with two sieve sleeves  
HIT-SC for setting through the fixture and/or through the non-loadbearing  
layer in hollow brick and solid brick ( Figure A4)**

HAS-U-...			M8		M10	
with HIT-SC	 		16x50+16x85	16x85+16x85	16x50+16x85	16x85+16x85
Nominal diameter of drill bit	$d_0$	[mm]	16	16	16	16
Drill hole depth	$h_0$	[mm]	145	180	145	180
Min. effective embedment depth	$h_{ef,min}$	[mm]	80	80	80	80
Max. thickness of non-loadbearing layer and fixture (through setting)	$h_{p,max}$	[mm]	50	80	50	80
Max. diameter of clearance hole in the fixture (pre-setting)	$d_{f1}$	[mm]	9	9	12	12
Max. diameter of clearance hole in the fixture (through setting)	$d_{f2}$	[mm]	17	17	17	17
Min. wall thickness	$h_{min}$	[mm]	$h_{ef}+65$	$h_{ef}+70$	$h_{ef}+65$	$h_{ef}+70$
Brush HIT-RB	-	[-]	16	16	16	16
Number of strokes HDM	-	[-]	4+6	6+6	4+6	6+6
Number of strokes HDE-500	-	[-]	3+5	5+5	3+5	5+5
Maximum torque moment for all brick types except "parpaing creux"	$T_{max}$	[Nm]	3	3	4	4
Maximum torque moment for "parpaing creux"	$T_{max}$	[Nm]	2	2	2	2

**Table B8 continued**

HAS-U-...			M12		M16	
with HIT-SC	 		18x50+18x85	18x85+18x85	22x50+22x85	22x85+22x85
Nominal diameter of drill bit	$d_0$	[mm]	18	18	22	22
Drill hole depth	$h_0$	[mm]	145	180	145	180
Min. effective embedment depth	$h_{ef,min}$	[mm]	80	80	80	80
Max. thickness of non-loadbearing layer and fixture (for through setting)	$h_{p,max}$	[mm]	50	80	50	80
Max. diameter of clearance hole in the fixture (pre-setting)	$d_{f1}$	[mm]	14	14	18	18
Max. diameter of clearance hole in the fixture (through setting)	$d_{f2}$	[mm]	19	19	23	23
Min. wall thickness	$h_{min}$	[mm]	$h_{ef}+65$	$h_{ef}+70$	$h_{ef}+65$	$h_{ef}+70$
Brush HIT-RB	-	[-]	18	18	22	22
Number of strokes HDM	-	[-]	4+8	8+8	6+10	10+10
Number of strokes HDE-500	-	[-]	5+8	8+8	5+8	8+8
Maximum torque moment for all brick types except "parpaing creux"	$T_{max}$	[Nm]	6	6	8	8
Maximum torque moment for "parpaing creux"	$T_{max}$	[Nm]	3	3	6	6

Hilti HIT-HY 270 with HAS-U

Intended Use  
Installation parameters

Annex B8

**Table B9: Maximum working time and minimum curing time for solid bricks <sup>1)</sup>**

Temperature in the base material T	Maximum working time $t_{work}$	minimum curing time $t_{cure}$
5 °C to 9 °C	10 min	2,5 h
10 °C to 19 °C	7 min	1,5 h
20 °C to 29 °C	4 min	30 min
30 °C to 40 °C	1 min	20 min

<sup>1)</sup> The curing time data are valid for dry base material only.  
In wet base material the curing times must be doubled.

**Table B10: Maximum working time and minimum curing time for hollow bricks <sup>1)</sup>**

Temperature in the base material T	Maximum working time $t_{work}$	minimum curing time $t_{cure}$
0 °C to 4 °C	10 min	4 h
5 °C to 9 °C	10 min	2,5 h
10 °C to 19 °C	7 min	1,5 h
20 °C to 29 °C	4 min	30 min
30 °C to 40 °C	1 min	20 min

<sup>1)</sup> The curing time data are valid for dry base material only.  
In wet base material the curing times must be doubled.

**Table B11: Cleaning alternatives**

**Manual Cleaning (MC):**

Hilti hand pump for blowing out drill hole diameter  $d_0 \leq 18$  mm and drill hole depth up to  $h_0 = 100$  mm.



**Compressed air cleaning (CAC):**

Air nozzle with an orifice opening of minimum 3,5 mm in diameter for blowing out drill hole depth up to  $h_0 = 300$  mm.



**Steel brush HIT-RB:**

according to tables B5 to B8 depending on drill hole diameter for MC and CAC



Hilti HIT-HY 270 with HAS-U

Intended Use  
Installation parameters  
Cleaning tools

Annex B9

## Installation

### Hole drilling

If no significant resistance is felt over the entire depth of the hole when drilling (e.g. in unfilled butt joints), the anchor should not be set at this position.

### Drilling mode

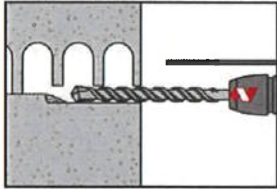

#### In hollow and solid bricks (use category c): rotary mode

Drill hole to the required embedment depth with a hammer drill set in rotation mode using an appropriately sized carbide drill bit.

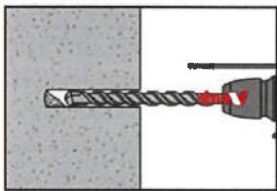

#### In solid bricks (use category b): hammer mode

Drill hole to the required embedment depth with a hammer drill set in hammer mode using an appropriately sized carbide drill bit.

### Drill hole cleaning

Just before setting the anchor, the drill hole must be free of dust and debris. Inadequate hole cleaning = poor load values.

### Manual Cleaning (MC): For hollow and solid bricks

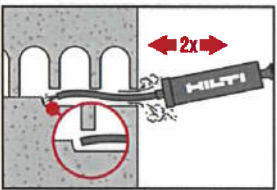

The Hilti hand pump may be used for blowing out drill holes up to diameters  $d_0 \leq 18$  mm and drill hole depths up to  $h_0 = 100$  mm. Blow out at least 2 times from the back of the drill hole until return air stream is free of noticeable dust

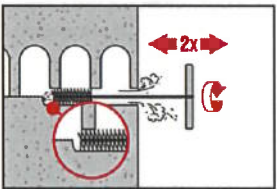

Brush 2 times with the specified steel brush (tables B5 to B8) by inserting the steel brush Hilti HIT-RB to the back of the hole (if needed with extension) in a twisting motion and removing it.

The brush must produce natural resistance as it enters the drill hole (brush  $\varnothing \geq$  drill hole  $\varnothing$ ) - if not the brush is too small and must be replaced with the proper brush diameter.

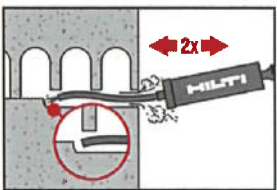

Blow out again with the Hilti hand pump at least 2 times until return air stream is free of noticeable dust.

Hilti HIT-HY 270 with HAS-U

Intended Use  
Installation instructions

Annex B10

**Compressed Air Cleaning (CAC):** For hollow and solid bricks

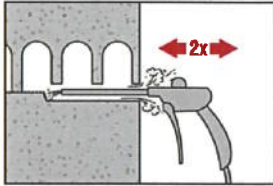

Blow 2 times from the back of the hole (if needed with nozzle extension) over the hole length with oil-free compressed air (min. 6 bar at 6 m<sup>3</sup>/h; drill hole depth up to h<sub>0</sub> = 300 mm) until return air stream is free of noticeable dust.

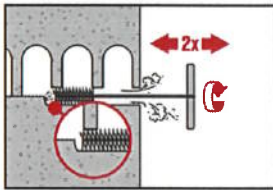

Brush 2 times with the specified steel brush (tables B5 to B8) by inserting the steel brush Hilti HIT-RB to the back of the hole (if needed with extension) in a twisting motion and removing it.  
The brush must produce natural resistance as it enters the drill hole (brush Ø ≥ drill hole Ø) - if not the brush is too small and must be replaced with the proper brush diameter.

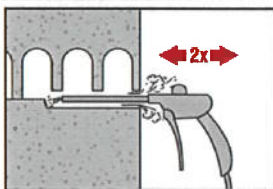

Blow again with Hilti hand pump or compressed air 2 times until return air stream is free of noticeable dust.

**Injection preparation in masonry with holes or voids: installation with sieve sleeve HIT-SC**

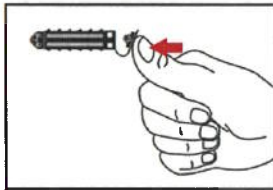

**Single sieve sleeve HIT-SC**  
Close lid

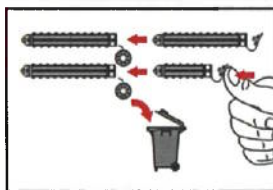

**Two sieve sleeves HIT-SC**  
Plug sieve sleeves together. Discard superfluous lid.  
Observe sieve sleeve order in case of different sieve sleeve lengths: shorter sleeve has to be plugged into longer sleeve.

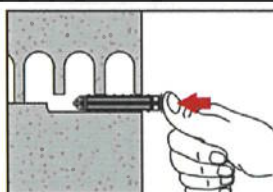

Insert sieve sleeve manually.  
When using two sieve sleeves, longer sieve sleeve has to be inserted first.

Hilti HIT-HY 270 with HAS-U

Intended Use  
Installation instructions

Annex B11

### For all applications

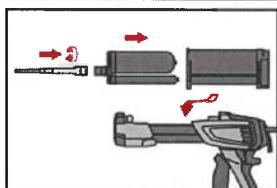

Tightly attach new Hilti mixing nozzle HIT-RE-M to foil pack manifold (snug fit). Do not modify the mixing nozzle. Observe the instruction for use of the dispenser and foil pack. Check foil pack holder for proper function. Do not use damaged foil packs / holders. Insert foil pack into foil pack holder and put holder into HIT-dispenser.

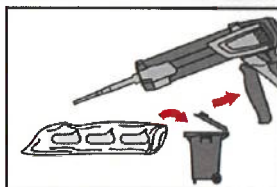

Discard initial adhesive. The foil pack opens automatically as dispensing is initiated. Depending on the size of the foil pack an initial amount of adhesive has to be discarded. Discarded quantities are

2 strokes	for 330 ml foil pack,
3 strokes	for 500 ml foil pack.

### Inject adhesive without forming air voids

#### Installation with sieve sleeve HIT-SC

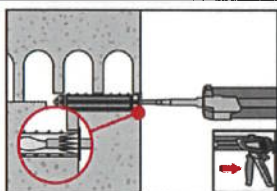

##### Single sieve sleeve HIT-SC

Insert mixer approximately 1 cm through the lid. Inject required amount of adhesive (see tables B5 to B8). Adhesive must emerge through the lid.

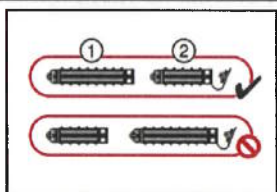

##### Two sieve sleeves HIT-SC

Use extension for installation with two sieve sleeves. Insert mixer approximately 1 cm through the tip of sieve sleeve "2" and inject required amount of adhesive into sieve sleeve "1" (see tables B5 to B8). Withdraw mixer to the point where it extends about 1 cm through the lid into the sleeve "2". Continue injecting in sieve sleeve "2" as described above.

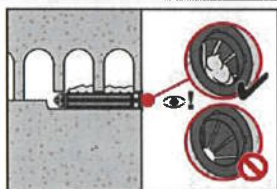

Control amount of injected mortar. Adhesive has to protrude into the lid.

After injection is completed, depressurize the dispenser by pressing the release trigger. This will prevent further adhesive discharge from the mixer.

Hilti HIT-HY 270 with HAS-U

Intended Use  
Installation instructions

Annex B12

### Solid bricks: installation without sieve sleeve

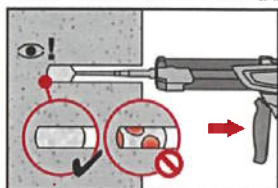

Inject the adhesive starting at the back of the hole, slowly withdrawing the mixer with each trigger pull.  
Fill holes approximately 2/3 full to ensure that the annular gap between the anchor and the base material is completely filled with adhesive along the embedment length.

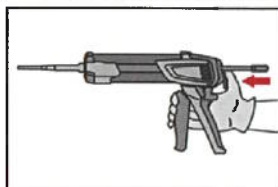

After injection is completed, depressurize the dispenser by pressing the release trigger. This will prevent further adhesive discharge from the mixer.

### Setting the element:

Before use, verify that the element is dry and free of oil and other contaminants.

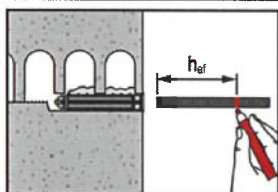

#### HAS-U-... in hollow and solid bricks: Pre-setting (Figure A1 to Figure A4)

Mark the element to the required embedment depth  $h_{ef}$  acc. to Table B5 to B7.

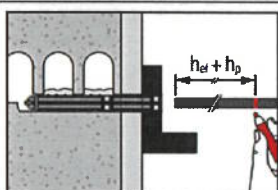

#### HAS-U-... in hollow and solid bricks: setting through the fixture ( Figure A4a)

#### or through the non-loadbearing layer and the fixture ( Figure A4b)

Mark the element to the required embedment depth  $h_{ef} + h_p$  acc. to Table B8.

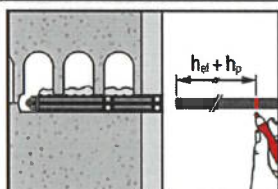

#### HAS-U-... in hollow and solid bricks: setting through the non-loadbearing ( Figure A4c)

Mark the element to the required embedment depth  $h_{ef} + h_p$  acc. to Table B8.

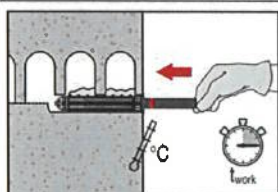

Set element to the required embedment depth until working time  $t_{work}$  has elapsed. The working time  $t_{work}$  is given in Table B9 and Table B10.

### Loading the anchor

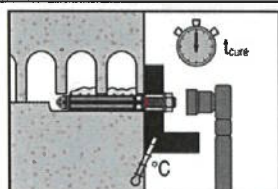

After required curing time  $t_{cure}$  (see Table B9 and Table B10) the anchor can be loaded.

The applied installation torque shall not exceed the values  $T_{max}$  given in tables B5 to B8.

Hilti HIT-HY 270 with HAS-U

Intended Use  
Installation instructions

Annex B13

**Table C1:  $\beta$ -factor for job-site testing under tension loading**

Use categories		w/w and w/d		d/d	
Temperature range		Ta*	Tb*	Ta*	Tb*
Base material	Cleaning				
Solid clay brick EN 771-1	CAC	0,96	0,96	0,96	0,96
	MC	0,84	0,84	0,84	0,84
Solid calcium silicate brick EN 771-2	CAC/MC	-	-	0,96	0,80
Solid light weight concrete brick EN 771-3	CAC	0,82	0,68	0,96	0,80
	MC	0,81	0,67	0,90	0,75
Solid normal weight concrete brick EN 771-3	CAC/MC	0,96	0,80	0,96	0,80
Hollow clay brick EN 771-1	CAC	0,96	0,96	0,96	0,96
	MC	0,84	0,84	0,84	0,84
Hollow calcium silicate brick EN 771-2	CAC/MC	-	-	0,96	0,80
Hollow light weight concrete brick EN 771-3	CAC	0,69	0,57	0,81	0,67
	MC	0,68	0,56	0,76	0,63
Hollow normal weight concrete brick EN 771-3	CAC/MC	0,96	0,80	0,96	0,80

\*Temperature range Ta / Tb see Annex B1

**Table C2: Characteristic values of steel resistance for HAS-U under tension and shear loads in masonry**

Steel failure tension loads		M6	M8	M10	M12	M16
Characteristic steel resistance	$N_{Rk,s}$ [kN]	$A_s \cdot f_{uk}$				
Steel failure shear loads without lever arm						
Characteristic steel resistance	$V_{Rk,s}$ [kN]	$0,5 \cdot A_s \cdot f_{uk}$				
Steel failure shear loads with lever arm						
Characteristic bending moment	$M_{Rk,s}$ [Nm]	$1,2 \cdot W_{el} \cdot f_{uk}$				

**Hilti HIT-HY 270 with HAS-U**

**Performances**

$\beta$ -factors for job-site testing under tension load  
Characteristic resistances under tension and shear load – steel failure

**Annex C1**

**Spacing dependent on edge distances for all anchor combinations:**

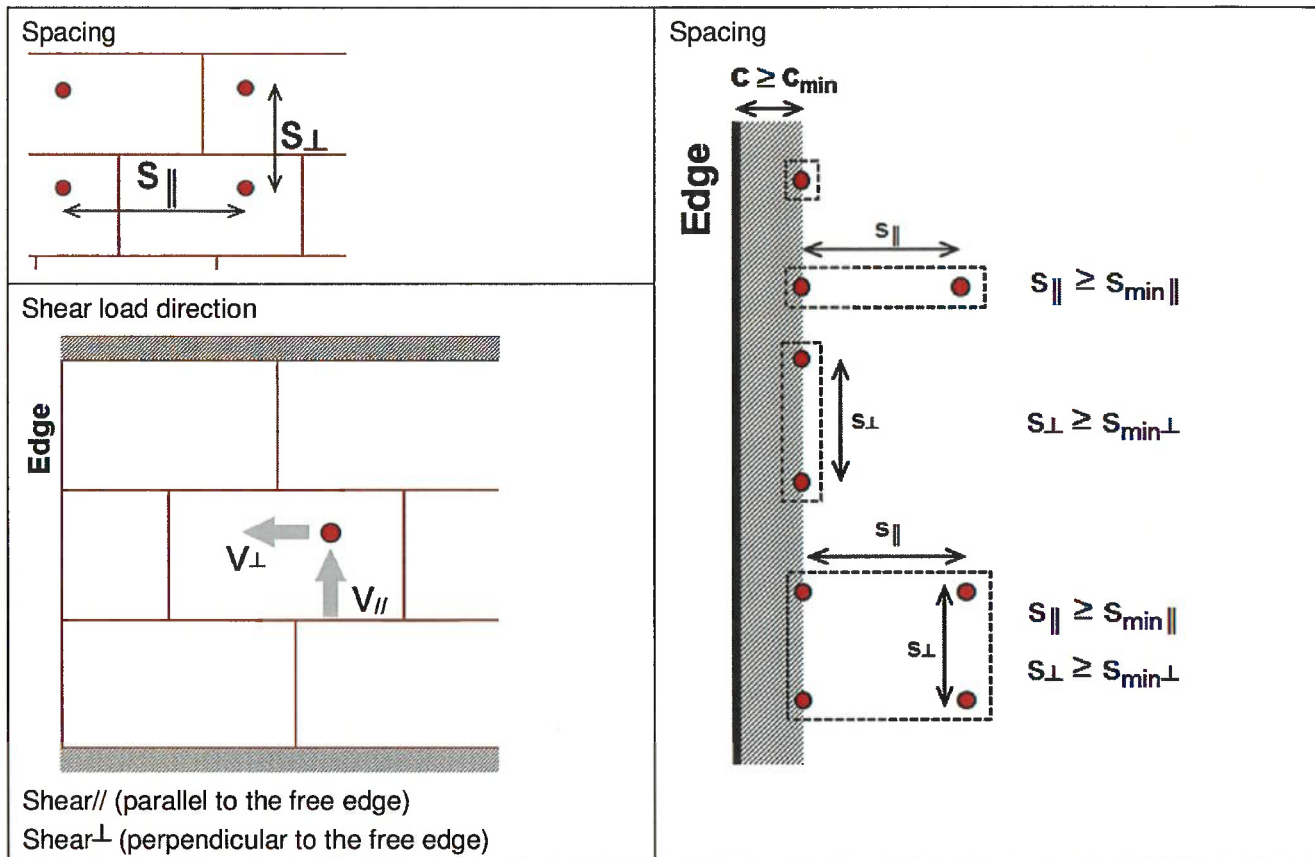

The characteristic values of resistance of an anchor group are calculated by using the group-factors  $\alpha_g$  according to Annexes C3 to C30:

Group of two anchors:  $N_{Rk}^g = \alpha_{g,N} \cdot N_{Rk}$  and  $V_{Rk}^g = \alpha_{g,V} \cdot V_{Rk}$  (with the relevant  $\alpha_g$ )

Group of four anchors:  $N_{Rk}^g = \alpha_{g,N||} \cdot \alpha_{g,N\perp} \cdot N_{Rk}$  and  $V_{Rk}^g = \alpha_{g,V||} \cdot \alpha_{g,V\perp} \cdot V_{Rk}$

**Hilti HIT-HY 270 with HAS-U**

**Performances**  
Anchor spacing  
Shear load direction

**Annex C2**



### Brick type: Solid clay brick Mz, 1DF

**Table C3: Description of brick**

Brick type		Solid Mz, 1DF	
Bulk density	$\rho$ [kg/dm <sup>3</sup> ]	2,0	
Compressive strength	$f_b$ [N/mm <sup>2</sup> ]	$\geq 12, \geq 20$ or $\geq 40$	
Code		EN 771 - 1	
Producer			
Brick dimensions	[mm]	$\geq 240 \times 115 \times 52$	
Minimum wall thickness	$h_{min}$ [mm]	$\geq 115$	





### Characteristic resistances for all anchor combinations (see Table B3)

**Table C4: Tension resistance at edge distance  $c \geq 115$  mm**

Use category			w/w = w/d		d/d	
Service temperature range			Ta	Tb	Ta	Tb
Anchor type and size	$h_{ef}$ [mm]	$f_b$ [N/mm <sup>2</sup> ]	$N_{Rk,p} = N_{Rk,b}$ [kN]			
All anchor	$\geq 50$	12	1,5 (2,0*)			
		20	2,0 (2,5*)			
		40	3,5 (4,0*)			
	$\geq 80$	12	2,5 (3,0*)			
		20	3,5 (4,0*)			
		40	5,5 (6,5*)			
	$\geq 100$	12	3,5 (4,0*)			
		20	4,5 (5,0*)			
		40	7,0 (8,0*)			

\* CAC cleaning only

Related edge and spacing distance and group factor  $\alpha_g$

Configuration	$c \geq$ [mm]	$s_{\perp} \geq$ [mm]	$\alpha_g$ [-]	Configuration	$c \geq$ [mm]	$s_{\parallel} \geq$ [mm]	$\alpha_g$ [-]
	115	-	-	-	-	-	-
	115	55	1,0		115	75	1,35
	115	115	2,0		115	$3 h_{ef}$	2,0

Hilti HIT-HY 270 with HAS-U

Performances solid clay brick Mz, 1DF

Characteristic values of resistance under tension load and group factor

Annex C3

**Table C5: Shear resistance at edge distance  $c \geq 115$  mm (for  $V_{II}$ ) and  $c \geq 1,5 h_{ef}$  (for  $V_{\perp}$ )**

Anchor type and size	$h_{ef}$ [mm]	$f_b$ [N/mm <sup>2</sup> ]	$V_{Rk,b} = V_{Rk,c II}$ [kN]	$V_{Rk,c \perp}$
HAS-U M8; M10	$\geq 50$	12	2,5	Calculate according to TR 054 equation 10
		20	3,0	
		40	4,0	
HAS-U M12; M16	$\geq 50$	12	3,5	
		20	4,5	
		40	5,5	
HAS-U M8; M10	$\geq 80$	12	5,0	
		20	6,0	
		40	7,5	
HAS-U M12; M16	$\geq 80$	12	6,5	
		20	8,5	
		40	10,5	

Related edge and spacing distance and group factor  $\alpha_g$

Configuration	$c \geq$ [mm]	$s_{\perp} \geq$ [mm]	$\alpha_g$ [-]	Configuration	$c \geq$ [mm]	$s_{\perp} \geq$ [mm]	$\alpha_g$ [-]
	115	-	-		$1,5 h_{ef}$	-	-
	115	55	1,0		$1,5 h_{ef}$	55	1,0
	115	115	2,0		$1,5 h_{ef}$	$3 h_{ef}$	2,0
Configuration	$c \geq$ [mm]	$s_{  }$ [mm]	$\alpha_g$ [-]	Configuration	$c \geq$ [mm]	$s_{  }$ [mm]	$\alpha_g$ [-]
-	-	-	-		$1,5 h_{ef}$	115	1,0
	115	75	2,0		$1,5 h_{ef}$	$3 h_{ef}$	2,0

**Table C6: Displacements**

$h_{ef}$	<b>N</b>	$\delta_{N0}$	$\delta_{N\infty}$	<b>V</b>	$\delta_{V0}$	$\delta_{V\infty}$
[mm]	[kN]	[mm]	[mm]	[kN]	[mm]	[mm]
50	1,2	0,1	0,2	1,4	0,5	0,75
80	2,1	0,1	0,2	2,1	1,1	1,65
100	3,9	0,2	0,4	3,0	1,3	1,95

Hilti HIT-HY 270 with HAS-U

Performances solid clay brick Mz, 1DF  
Characteristic values of resistance under shear load and group factor  
Displacements

Annex C4

**Brick type: Solid clay brick Mz, NF**

**Table C7: Description of brick**

Brick type		Solid Mz, NF	
Bulk density	$\rho$ [kg/dm <sup>3</sup> ]	2,0	
Compressive strength	$f_b$ [N/mm <sup>2</sup> ]	≥ 10 / 20	
Code		EN 771 - 1	
Producer			
Brick dimensions	[mm]	≥ 240 x 115 x 71	
Minimum wall thickness	$h_{min}$ [mm]	≥ 115	





**Characteristic resistances for all anchor combinations (see Table B3)**

**Table C8: Tension resistance at edge distance  $c \geq 50$  mm**

Use category			w/w = w/d		d/d	
Service temperature range			Ta	Tb	Ta	Tb
Anchor type and size	$h_{ef}$ [mm]	$f_b$ [N/mm <sup>2</sup> ]	$N_{Rk,p} = N_{Rk,b}$ [kN]			
All anchor	≥ 50	10	1,5 (1,5*)			
		20	2,0 (2,0*)			
	≥ 80	10	2,5 (3,0*)			
		20	3,5 (4,0*)			

\* CAC cleaning only

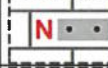
Related edge and spacing distance and group factor  $\alpha_g$

Configuration	$c \geq$ [mm]	$s_{\perp} \geq$ [mm]	$\alpha_g$ [-]	Configuration	$c \geq$ [mm]	$s_{\parallel} \geq$ [mm]	$\alpha_g$ [-]
	50	-	-	-	-	-	-
	50	75	1,0		115	50	1,0
-	-	-	-		50	115	1,15
	50	150	2,0		50	3 $h_{ef}$	2,0

**Hilti HIT-HY 270 with HAS-U**

**Performances solid clay brick Mz, NF**

Characteristic values of resistance under tension load and group factor

**Annex C5**

**Table C9: Tension resistance at edge distance for  $h_{ef} \geq 100$  mm at  $c \geq 150$  mm**

Use category			w/w = w/d		d/d	
Service temperature range			Ta	Tb	Ta	Tb
Anchor type and size	$h_{ef}$ [mm]	$f_b$ [N/mm <sup>2</sup> ]	$N_{Rk,p} = N_{Rk,b}$ [kN]			
All anchor	$\geq 100$	10	4,0 (4,5*)			
		20	5,5 (6,0*)			

\* CAC cleaning only

Related edge and spacing distance and group factor  $\alpha_g$

Configuration	$c \geq$ [mm]	$s_{\perp} \geq$ [mm]	$\alpha_g$ [-]	Configuration	$c \geq$ [mm]	$s_{\parallel} \geq$ [mm]	
	150	-	-	-	-	-	-
	150	75	1,40		150	50	0,75
-	-	-	-		150	115	1,35
	150	150	2,0		150	3 $h_{ef}$	2,0

**Table C10: Shear resistance at edge distance  $c \geq 1,5 h_{ef}$**

Anchor type and size	$h_{ef}$ [mm]	$f_b$ [N/mm <sup>2</sup> ]	$V_{Rk,b} = V_{Rk,c \parallel}$ [kN]	$V_{Rk,c \perp}$
All anchor	$\geq 50$	10	3,0	Calculate according to TR 054 equation 10
		20	4,5	
HAS-U M8; M10	$\geq 80$	10	5,0	
		20	7,0	
HAS-U M8; M10	$\geq 100$	10	8,0	
		20	11,0	
HAS-U M12; M16	$\geq 80$	10	9,0	
		20	12,0	

Related edge and spacing distance and group factor  $\alpha_g$

Configuration	$c \geq$ [mm]	$s_{\perp} \geq$ [mm]	$\alpha_g$ [-]	Configuration	$c \geq$ [mm]	$s_{\perp} \geq$ [mm]	$\alpha_g$ [-]
	1,5 $h_{ef}$	-	-		1,5 $h_{ef}$	-	-
	1,5 $h_{ef}$	75	1,55		1,5 $h_{ef}$	75	1,0
	1,5 $h_{ef}$	150	2,0		1,5 $h_{ef}$	3 $h_{ef}$	2,0
Configuration	$c \geq$ [mm]	$s_{\parallel}$ [mm]	$\alpha_g$ [-]	Configuration	$c \geq$ [mm]	$s_{\parallel}$ [mm]	$\alpha_g$ [-]
	1,5 $h_{ef}$	50	1,2		1,5 $h_{ef}$	50	1,60
	1,5 $h_{ef}$	75	1,5		1,5 $h_{ef}$	3 $h_{ef}$	2,0
	1,5 $h_{ef}$	115	2,0	-	-	-	-

Hilti HIT-HY 270 with HAS-U





Performances solid clay brick Mz, NF  
Characteristic values of resistance under tension load and group factor

Annex C6

**Table C11: Shear resistance at edge distance  $c \geq 50$  mm**

Anchor type and size	$h_{ef}$ [mm]	$f_b$ [N/mm <sup>2</sup> ]	$V_{Rk,b} = V_{Rk,c II}$ [kN]
All anchor	$\geq 50$	10	3,0
		20	4,5
	$\geq 80$	10	4,0
		20	5,5

Related edge and spacing distance and group factor  $\alpha_g$

Configuration	$c \geq$ [mm]	$s_{\perp} \geq$ [mm]	$\alpha_g$ [-]
	50	-	-
	50	75	1,55
	50	150	2,0
Configuration	$c \geq$ [mm]	$s_{  }$ [mm]	$\alpha_g$ [-]
	50	50	1,2
	50	115	2,0

**Table C12: Displacements**

$h_{ef}$ [mm]	<b>N</b> [kN]	$\delta_{N0}$ [mm]	$\delta_{N\infty}$ [mm]	<b>V</b> [kN]	$\delta_{V0}$ [mm]	$\delta_{V\infty}$ [mm]
50	0,8	0,1	0,2	1,6	0,8	1,2
80	1,5	0,1	0,2	2,1	0,8	1,2
100	2,3	0,1	0,2	2,1	0,8	1,2

**Hilti HIT-HY 270 with HAS-U**

**Performances solid clay brick Mz, NF**

Characteristic values of resistance under shear load and group factor  
Displacements

**Annex C7**

**Brick type: Solid clay brick Mz, 2DF**

**Table C13: Description of brick**

Brick type		Solid Mz, 2DF	
Bulk density	$\rho$ [kg/dm <sup>3</sup> ]	$\geq 2,0$	
Compressive strength	$f_b$ [N/mm <sup>2</sup> ]	$\geq 12 / 20$	
Code		EN 771 - 1	
Producer			
Brick dimensions	[mm]	$\geq 240 \times 115 \times 113$	
Minimum wall thickness	$h_{min}$ [mm]	$\geq 115$	







**Characteristic resistances for all anchor combinations (see Table B3)**

**Table C14: Tension resistance at edge distance  $c \geq 115$  mm**

Use category	Service temperature range		w/w = w/d		d/d	
			Ta	Tb	Ta	Tb
Anchor type and size	$h_{ef}$ [mm]	$f_b$ [N/mm <sup>2</sup> ]	$N_{Rk,p} = N_{Rk,b}$ [kN]			
All anchor	$\geq 50$	12	2,5 (3,0*)			
		20	2,5 (3,0*)			
	$\geq 80$	12	3,5 (4,0*)			
		20	4,5 (5,5*)			
	$\geq 100$	12	6,0 (7,0*)			
		20	7,0 (8,0*)			

\* CAC cleaning only

Related edge and spacing distance and group factor  $\alpha_g$

Configuration	$c \geq$ [mm]	$s_{\perp} \geq$ [mm]	$\alpha_g$ [-]	Configuration	$c \geq$ [mm]	$s_{\parallel} \geq$ [mm]	$\alpha_g$ [-]
	115	-	-	-	-	-	-
	115	75	1,0		115	75	1,50
	115	115	1,60	-	-	-	-
	115	3 $h_{ef}$	2,0		115	3 $h_{ef}$	2,0

**Hilti HIT-HY 270 with HAS-U**

**Performances solid clay brick Mz, 2DF**  
Characteristic values of resistance under tension load and group factor

**Annex C8**

**Table C15: Tension resistance at edge distance  $c \geq 50$  mm**

Use category			w/w = w/d		d/d	
Service temperature range			Ta	Tb	Ta	Tb
Anchor type and size	$h_{ef}$ [mm]	$f_b$ [N/mm <sup>2</sup> ]	$N_{Rk,p} = N_{Rk,b}$ [kN]			
All anchor	$\geq 50$	12	1,5 (1,5*)			
		20	2,0 (2,0*)			
	$\geq 80$	12	3,0 (3,5*)			
		20	3,5 (4,0*)			

\* CAC cleaning only

Related edge and spacing distance and group factor  $\alpha_g$

Configuration	$c \geq$ [mm]	$s_{\perp} \geq$ [mm]	$\alpha_g$ [-]	Configuration	$c \geq$ [mm]	$s_{\parallel} \geq$ [mm]	$\alpha_g$ [-]
	50	-	-	-	-	-	-
	50	75	1,10		115	50	1,0
	50	115	1,45		50	115	1,15
	50	3 $h_{ef}$	2,0		50	3 $h_{ef}$	2,0

**Table C16: Shear resistance at edge distance  $c \geq 1,5 h_{ef}$**

Anchor type and size	$h_{ef}$ [mm]	$f_b$ [N/mm <sup>2</sup> ]	$V_{Rk,b} = V_{Rk,c \parallel}$ [kN]	$V_{Rk,c \perp}$
All anchor	$\geq 50$	12	5,5	Calculate according to TR 054 equation 10 (for $h_{ef} > 80$ mm calculate with $h_{ef} = 80$ mm)
		20	7,0	
HAS-U M8; M10	$\geq 80$	12	8,0	
		20	10,0	
HAS-U M12	$\geq 80$	12	10,5	
		20	12,0	
HAS-U M16	$\geq 80$	12	12,0	
		20	12,0	

Related edge and spacing distance and group factor  $\alpha_g$

Configuration	$c \geq$ [mm]	$s_{\perp} c$ [mm]	$\alpha_g$ [-]	Configuration	$c \geq$ [mm]	$s_{\perp} \geq$ [mm]	$\alpha_g$ [-]
	1,5 $h_{ef}$	-	-		1,5 $h_{ef}$	-	-
	1,5 $h_{ef}$	75	0,85		1,5 $h_{ef}$	115	0,75
	1,5 $h_{ef}$	3 $h_{ef}$	2,0		1,5 $h_{ef}$	3 $h_{ef}$	2,0
Configuration	$c \geq$ [mm]	$s_{\parallel}$ [mm]	$\alpha_g$ [-]	Configuration	$c \geq$ [mm]	$s_{\parallel}$ [mm]	$\alpha_g$ [-]
	1,5 $h_{ef}$	115	1,60		1,5 $h_{ef}$	115	0,8
	1,5 $h_{ef}$	3 $h_{ef}$	2,0		1,5 $h_{ef}$	3 $h_{ef}$	2,0

Hilti HIT-HY 270 with HAS-U

Performances solid clay brick Mz, 2DF

Characteristic values of resistance under tension and shear load and group factor

Annex C9

**Table C17: Shear resistance at edge distance  $c \geq 50$  mm**

Anchor type and size	$h_{ef}$ [mm]	$f_b$ [N/mm <sup>2</sup> ]	$V_{Rk,b} = V_{Rk,cII}$ [kN]
All anchor	$\geq 50$	12	3,0
		20	4,0
All anchor	$\geq 80$	12	4,5
		20	5,5

Related edge and spacing distance and group factor  $\alpha_g$

Configuration	$c \geq$ [mm]	$s_{\perp} \geq$ [mm]	$\alpha_g$ [-]
	50	-	-
	50	75	0,70
	50	115	1,5
	50	$3 h_{ef}$	2,0
Configuration	$c \geq$ [mm]	$s_{  }$ [mm]	$\alpha_g$ [-]
	50	115	2,0

**Table C18: Displacements**

$h_{ef}$ [mm]	<b>N</b> [kN]	$\delta_{N0}$ [mm]	$\delta_{N\infty}$ [mm]	<b>V</b> [kN]	$\delta_{V0}$ [mm]	$\delta_{V\infty}$ [mm]
50	0,9	0,1	0,2	1,9	0,6	0,9
80	1,3	0,2	0,4	2,8	1,0	1,5
100	1,7	0,3	0,6	2,8	1,0	1,5

**Hilti HIT-HY 270 with HAS-U**

**Performances solid clay brick Mz, 2DF**

Characteristic values of resistance under shear load and group factor  
Displacements

**Annex C10**



**Brick type: Solid calcium silicate brick KS, 2DF**

**Table C19: Description of brick**







Brick type		Solid KS, 2DF	
Bulk density	$\rho$ [kg/dm <sup>3</sup> ]	$\geq 2,0$	
Compressive strength	$f_b$ [N/mm <sup>2</sup> ]	$\geq 12 / 28$	
Code		EN 771 - 2	
Producer			
Brick dimensions	[mm]	$\geq 240 \times 115 \times 113$	
Minimum wall thickness	$h_{min}$ [mm]	$\geq 115$	

**Characteristic resistances for all anchor combinations (see Table B3)**

**Table C20: Tension resistance at edge distance  $c \geq 115$  mm**

Use category			w/w = w/d		d/d	
Service temperature range			Ta	Tb	Ta	Tb
Anchor type and size	$h_{ef}$ [mm]	$f_b$ [N/mm <sup>2</sup> ]	$N_{Rk,p} = N_{Rk,b}$ [kN]			
All anchor	$\geq 50$	12	-	-	6,0	5,0
		28	-	-	9,0	7,5

Related edge and spacing distance and group factor  $\alpha_g$



Configuration	$c \geq$ [mm]	$s_{\perp} \geq$ [mm]	$\alpha_g$ [-]	Configuration	$c \geq$ [mm]	$s_{  } \geq$ [mm]	$\alpha_g$ [-]
	115	-	-	-	-	-	-
	115	50	1,0		115	50	1,0
	115	115	1,45	-	-	-	-
	115	150	2,0		115	115 (H)* 240 (S)*	2,0

\* (H) = Header, (S) = Stretcher

**Table C21: Tension resistance at edge distance  $c \geq 50$  mm**

Use category			w/w = w/d		d/d	
Service temperature range			Ta	Tb	Ta	Tb
Anchor type and size	$h_{ef}$ [mm]	$f_b$ [N/mm <sup>2</sup> ]	$N_{Rk,p} = N_{Rk,b}$ [kN]			
All anchor	$\geq 50$	12	-	-	4,0	3,5
		28	-	-	6,5	5,5

Related edge and spacing distance and group factor  $\alpha_g$

Configuration	$c \geq$ [mm]	$s_{\perp} \geq$ [mm]	$\alpha_g$ [-]	Configuration	$c \geq$ [mm]	$s_{  } \geq$ [mm]	$\alpha_g$ [-]
	50	-	-	-	-	-	-
	50	115	2,0		50	115 (H)* 240 (S)*	2,0

\* (H) = Header, (S) = Stretcher

**Hilti HIT-HY 270 with HAS-U**

**Performances solid silica brick KS, 2DF**  
Characteristic values of resistance under tension load and group factor

**Annex C11**

**Table C22: Shear resistance at edge distance  $c \geq 115$  mm**

Anchor type and size	$h_{ef}$ [mm]	$f_b$ [N/mm <sup>2</sup> ]	$V_{Rk,b} = V_{Rk,c II}$ [kN]	$V_{Rk,c \perp}$
All anchor	$\geq 50$	12	6,0	Calculate according to TR 054 equation 10
		28	9,0	

Related edge and spacing distance and group factor  $\alpha_g$

Configuration	$c \geq$ [mm]	$s_{\perp} \geq$ [mm]	$\alpha_g$ [-]	Configuration	$c \geq$ [mm]	$s_{\perp} \geq$ [mm]	$\alpha_g$ [-]
	115	-	-		115	-	-
	115	50	0,45		115	50	0,45
	115	115	2,0		115	115	2,0
Configuration	$c \geq$ [mm]	$s_{  }$ [mm]	$\alpha_g$ [-]	Configuration	$c \geq$ [mm]	$s_{  }$ [mm]	$\alpha_g$ [-]
	115	50	0,45		115	50	0,45
	115	115 (H)* 240 (S)*	2,0		115	115 (H)* 240 (S)*	2,0

\* (H) = Header, (S) = Stretcher

**Table C23: Shear resistance at edge distance  $c \geq 50$  mm**

Anchor type and size	$h_{ef}$ [mm]	$f_b$ [N/mm <sup>2</sup> ]	$V_{Rk,b} = V_{Rk,c II} = V_{Rk,c \perp}$ [kN]
All anchor	$\geq 50$	12	3,0
		28	4,5

Related edge and spacing distance and group factor  $\alpha_g$

Configuration	$c \geq$ [mm]	$s_{\perp} \geq$ [mm]	$\alpha_g$ [-]	Configuration	$c \geq$ [mm]	$s_{\perp} \geq$ [mm]	$\alpha_g$ [-]
	50	-	-		50	-	-
	50	115	2,0		50	115	2,0
Configuration	$c \geq$ [mm]	$s_{  }$ [mm]	$\alpha_g$ [-]	Configuration	$c \geq$ [mm]	$s_{  }$ [mm]	$\alpha_g$ [-]
	50	115 (H)* 240 (S)*	2,0		50	115 (H)* 240 (S)*	2,0

\* (H) = Header, (S) = Stretcher

**Table C24: Displacements**

$h_{ef}$	<b>N</b>	$\delta_{N0}$	$\delta_{N\infty}$	<b>V</b>	$\delta_{V0}$	$\delta_{V\infty}$
[mm]	[kN]	[mm]	[mm]	[kN]	[mm]	[mm]
$\geq 50$	2,5	0,3	0,6	2,5	1,0	1,5

Hilti HIT-HY 270 with HAS-U

Performances solid silica brick KS, 2DF  
Characteristic values of resistance under tension and shear load and group factor  
Displacements

Annex C12





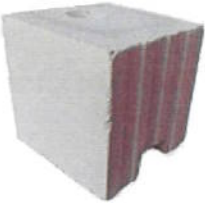

**Brick type: Solid calcium silicate brick KS, 8DF**

**Table C25: Description of brick**

Brick type		Solid KS, 8DF		
Bulk density	$\rho$	[kg/dm <sup>3</sup> ]		$\geq 2,0$
Compressive strength	$f_b$	[N/mm <sup>2</sup> ]		$\geq 12 / 20 / 28$
Code				EN 771 - 2
Producer				
Brick dimensions		[mm]		$\geq 248 \times 240 \times 248$
Minimum wall thickness	$h_{min}$	[mm]		$\geq 240$

**Characteristic resistances for all anchor combinations (see Table B3)**

**Table C26: Tension resistance at edge distance  $c \geq 120$  mm**

Use category			w/w = w/d		d/d	
Service temperature range			Ta	Tb	Ta	Tb
Anchor type and size	$h_{ef}$ [mm]	$f_b$ [N/mm <sup>2</sup> ]	$N_{Rk,p} = N_{Rk,b}$ [kN]			
All anchor	$\geq 50$	12	-	-	7,0	5,5
		20	-	-	9,0	7,5
		28	-	-	10,5	8,5
HAS-U M8, M10 	$\geq 80$	12	-	-	8,5	7,0
		20	-	-	11,0	9,0
		28	-	-	12,0	10,5
HAS-U M12 	$\geq 80$	12	-	-	11,5	9,5
		20	-	-	12,0	12,0
HAS-U + HIT-SC M8, M10 	$\geq 80$	28	-	-	12,0	12,0
		12	-	-	12,0	12,0
HAS-U M16 	$\geq 80$	20	-	-	12,0	12,0
		28	-	-	12,0	12,0
		12	-	-	12,0	11,0
HAS-U + HIT-SC M12, M16 	$\geq 80$	20	-	-	12,0	12,0
		28	-	-	12,0	12,0
		12	-	-	12,0	11,0
HAS-U M8, M10 	$\geq 100$	20	-	-	12,0	12,0
		28	-	-	12,0	12,0
		12	-	-	12,0	11,0



**Hilti HIT-HY 270 with HAS-U**

**Performances solid silica brick KS, 8DF**  
Characteristic values of resistance under tension load



**Annex C13**

English translation prepared by DIBt







**Table C26 continued**

HAS-U 	M12, M16	≥ 100	12	-	-	12,0	12,0
HAS-U + HIT-SC 	M8 to M16		20	-	-	12,0	12,0
			28	-	-	12,0	12,0

Related edge and spacing distance and group factor  $\alpha_g$

Configuration	c ≥ [mm]	s <sub>L</sub> ≥ [mm]	$\alpha_g$ [-]	Configuration	c ≥ [mm]	s <sub>ll</sub> ≥ [mm]	$\alpha_g$ [-]
	120	-	-	-	-	-	-
	120	3 h <sub>ef</sub>	2,0		120	3 h <sub>ef</sub>	2,0

**Table C27: Tension resistance at edge distance c ≥ 50 mm**



Use category			w/w = w/d		d/d	
Service temperature range			Ta	Tb	Ta	Tb
Anchor type and size	h <sub>ef</sub> [mm]	f <sub>b</sub> [N/mm <sup>2</sup> ]	N <sub>Rk,p</sub> = N <sub>Rk,b</sub> [kN]			
All anchor	≥ 50	12	-	-	4,0	3,5
		20	-	-	5,5	4,5
		28	-	-	6,5	5,0
HAS-U 	M8, M10	12	-	-	5,0	4,0
		20	-	-	6,5	5,5
		28	-	-	7,5	6,5
HAS-U 	M12	12	-	-	7,0	5,5
		20	-	-	9,0	7,5
		28	-	-	10,5	8,5
HAS-U + HIT-SC 	M8, M10	12	-	-	10,0	8,0
		20	-	-	12,0	10,5
		28	-	-	12,0	12,0
HAS-U 	M16	12	-	-	8,0	6,5
		20	-	-	10,5	8,5
		28	-	-	12,0	10,0
HAS-U + HIT-SC 	M12, M16	12	-	-	8,0	6,5
		20	-	-	10,5	8,5
		28	-	-	12,0	10,0
HAS-U 	M8, M10	12	-	-	8,0	6,5
		20	-	-	10,5	8,5
		28	-	-	12,0	10,0

**Hilti HIT-HY 270 with HAS-U**



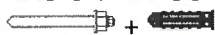

**Performances solid silica brick KS, 8DF**  
Characteristic values of resistance under tension load and group factor

**Annex C14**

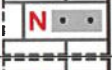

**Table C27 continued**

HAS-U 	M12	$\geq 100$	12	-	-	9,5	8,0
HAS-U + HIT-SC 	M8, M10		20	-	-	12,0	10,0
			28	-	-	12,0	12,0
HAS-U 	M16		12	-	-	12,0	10,5
HAS-U + HIT-SC 	M12, M16		20	-	-	12,0	12,0
			28	-	-	12,0	12,0







Related edge and spacing distance and group factor  $\alpha_g$

Configuration	$c \geq$ [mm]	$s_{\perp} \geq$ [mm]	$\alpha_g$ [-]	Configuration	$c \geq$ [mm]	$s_{\parallel} \geq$ [mm]	$\alpha_g$ [-]
	50	-	-	-	-	-	-
	50	50	1,0		50	50	1,0
	50	$3 h_{ef}$	2,0		50	$3 h_{ef}$	2,0

**Table C28: Shear resistance at edge distance  $c \geq 120$  mm (for  $V_{\parallel}$ ) and  $c \geq 1,5 h_{ef}$  (for  $V_{\perp}$ )**

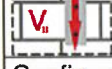
Anchor type and size	$h_{ef}$ [mm]	$f_b$ [N/mm <sup>2</sup> ]	$V_{Rk,b} = V_{Rk,c \parallel}$ [kN]	$V_{Rk,c \perp}$
HAS-U 	$\geq 50$	12	9,0	Calculate according to TR 054 equation 10
		20	12,0	
		28	12,0	
HAS-U 		12	12,0	
HAS-U + HIT-SC 		20	12,0	
		28	12,0	

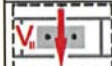
Related edge and spacing distance and group factor  $\alpha_g$

Configuration	$c \geq$ [mm]	$s_{\perp} \geq$ [mm]	$\alpha_g$ [-]	Configuration	$c \geq$ [mm]	$s_{\perp} \geq$ [mm]	$\alpha_g$ [-]
	120	-	-		$1,5 h_{ef}$	-	-
	120	$3 h_{ef}$	2,0		$1,5 h_{ef}$	$3 h_{ef}$	2,0
Configuration	$c \geq$ [mm]	$s_{\parallel}$ [mm]	$\alpha_g$ [-]	Configuration	$c \geq$ [mm]	$s_{\parallel}$ [mm]	$\alpha_g$ [-]
	120	$3 h_{ef}$	2,0		$1,5 h_{ef}$	$3 h_{ef}$	2,0

**Hilti HIT-HY 270 with HAS-U**

**Performances solid silica brick KS, 8DF**  
Characteristic values of resistance under tension and shear load and group factor

**Annex C15**

**Table C29: Shear resistance at edge distance  $c \geq 50$  mm**

Anchor type and size	$h_{ef}$ [mm]	$f_b$ [N/mm <sup>2</sup> ]	$V_{Rk,b} = V_{Rk,c II} = V_{Rk,c \perp}$ [kN]
All anchor	$\geq 50$	12	3,0
		20	4,0
		28	4,5

Related edge and spacing distance and group factor  $\alpha_g$

Configuration	$c \geq$ [mm]	$s_{\perp} \geq$ [mm]	$\alpha_g$ [-]	Configuration	$c \geq$ [mm]	$s_{\perp} \geq$ [mm]	$\alpha_g$ [-]
	50	-	-		50	-	-
	50	250	2,0		50	250	2,0
Configuration	$c \geq$ [mm]	$s_{  }$ [mm]	$\alpha_g$ [-]	Configuration	$c \geq$ [mm]	$s_{  }$ [mm]	$\alpha_g$ [-]
	50	250	2,0		50	250	2,0

**Table C30: Displacements**

$h_{ef}$ [mm]	$N$ [kN]	$\delta_{N0}$ [mm]	$\delta_{N\infty}$ [mm]	$V$ [kN]	$\delta_{V0}$ [mm]	$\delta_{V\infty}$ [mm]
50	2,3	0,10	0,20	3,4	2,8	4,2
80	3,4	0,15	0,30	3,4	2,8	4,2
100	3,4	0,15	0,30	3,4	2,8	4,2

Hilti HIT-HY 270 with HAS-U

Performances solid silica brick KS, 8DF  
Characteristic values of resistance under shear load and group factor  
Displacements

Annex C16

**Brick type: Solid lightweight concrete brick Vbl, 2DF**

**Table C31: Description of brick**

Brick type	Solid Vbl, 2DF		
Bulk density	$\rho$ [kg/dm <sup>3</sup> ]	$\geq 0,9$	
Compressive strength	$f_b$ [N/mm <sup>2</sup> ]	$\geq 4 / 6$	
Code	EN 771-3		
Producer			
Brick dimensions	[mm]	$\geq 240 \times 115 \times 113$	
Minimum wall thickness	$h_{min}$ [mm]	$\geq 115$	



**Characteristic resistances for all anchor combinations (see Table B3)**

**Table C32: Tension resistance at edge distance  $c \geq 115$  mm**

Use category			w/w = w/d		d/d	
Service temperature range			Ta	Tb	Ta	Tb
Anchor type and size	$h_{ef}$ [mm]	$f_b$ [N/mm <sup>2</sup> ]	$N_{Rk,p} = N_{Rk,b}$ [kN]			
All anchor	$\geq 50$	4	3,0	2,0	3,0 (3,5*)	2,5
		6	3,5	3,0	4,0	3,0 (3,5*)
	$\geq 80$	4	4,5	3,5	5,0	4,0 (4,5*)
		6	5,5	4,5	6,0 (6,5*)	5,0 (5,5*)
	$\geq 100$	4	6,0	5,0	6,5 (7,0*)	5,5 (6,0*)
		6	7,5	6,0	8,0 (8,5*)	6,5 (7,0*)

\* Compressed air cleaning only







Related edge and spacing distance and group factor  $\alpha_g$

Configuration	$c \geq$ [mm]	$s_{\perp} \geq$ [mm]	$\alpha_g$ [-]	Configuration	$c \geq$ [mm]	$s_{\parallel} \geq$ [mm]	$\alpha_g$ [-]
	115	-	-	-	-	-	-
	115	$3 h_{ef}$	2,0		115	$3 h_{ef}$	2,0

**Table C33: Tension resistance at edge distance  $c \geq 50$  mm**

Use category			w/w = w/d		d/d	
Service temperature range			Ta	Tb	Ta	Tb
Anchor type and size	$h_{ef}$ [mm]	$f_b$ [N/mm <sup>2</sup> ]	$N_{Rk,p} = N_{Rk,b}$ [kN]			
All anchor	$\geq 50$	4	1,5	1,2	1,5	1,5
		6	2,0	1,5	2,0	1,5

Related edge and spacing distance and group factor  $\alpha_g$

Configuration	$c \geq$ [mm]	$s_{\perp} \geq$ [mm]	$\alpha_g$ [-]	Configuration	$c \geq$ [mm]	$s_{\parallel} \geq$ [mm]	$\alpha_g$ [-]
	50	-	-	-	-	-	-
	50	115	1,0		50	115	1,0
	115	50	1,0		115	50	1,0
	50	$3 h_{ef}$	2,0		50	$3 h_{ef}$	2,0

**Hilti HIT-HY 270 with HAS-U**

**Performances solid lightweight concrete brick Vbl, 2DF**  
Characteristic values of resistance under tension load and group factor

**Annex C17**

**Table C34: Shear resistance at edge distance  $c \geq 115$  mm (for  $V_{II}$ ) and  $c \geq 1,5 h_{ef}$  (for  $V_{\perp}$ )**

Anchor type and size	$h_{ef}$ [mm]	$f_b$ [N/mm <sup>2</sup> ]	$V_{RK,b} = V_{RK,c II}$ [kN]	$V_{RK,c \perp}$
HAS-U M8	$\geq 50$	4	2,0	Calculate according to TR 054 equation 10
		6	2,5	
HAS-U M10 to M16		4	2,5	
		6	3,0	

Related edge and spacing distance and group factor  $\alpha_g$

Configuration	$c \geq$ [mm]	$s_{\perp} \geq$ [mm]	$\alpha_g$ [-]	Configuration	$c \geq$ [mm]	$s_{\perp} \geq$ [mm]	$\alpha_g$ [-]
	115	-	-		$1,5 h_{ef}$	-	-
	115	$3 h_{ef}$	2,0		$1,5 h_{ef}$	$3 h_{ef}$	2,0
Configuration	$c \geq$ [mm]	$s_{II}$ [mm]	$\alpha_g$ [-]	Configuration	$c \geq$ [mm]	$s_{II}$ [mm]	$\alpha_g$ [-]
	115	$3 h_{ef}$	2,0		$1,5 h_{ef}$	$3 h_{ef}$	2,0

**Table C35: Shear resistance at edge distance  $c \geq 50$  mm**

Anchor type and size	$h_{ef}$ [mm]	$f_b$ [N/mm <sup>2</sup> ]	$V_{RK,b} = V_{RK,c II} = V_{RK,c \perp}$ [kN]
All anchor	$\geq 50$	4	1,20
		6	1,50

Related edge and spacing distance and group factor  $\alpha_g$

Configuration	$c \geq$ [mm]	$s_{\perp} \geq$ [mm]	$\alpha_g$ [-]	Configuration	$c \geq$ [mm]	$s_{\perp} \geq$ [mm]	$\alpha_g$ [-]
	50	-	-		50	-	-
	115	50	1,0		115	50	1,0
	50	115	1,0		50	115	1,0
	50	$3 h_{ef}$	2,0		50	$3 h_{ef}$	2,0
Configuration	$c \geq$ [mm]	$s_{II}$ [mm]	$\alpha_g$ [-]	Configuration	$c \geq$ [mm]	$s_{II}$ [mm]	$\alpha_g$ [-]
	115	50	1,0		115	50	1,0
	50	115	1,0		50	115	1,0
	50	$3 h_{ef}$	2,0		50	$3 h_{ef}$	2,0

**Table C36: Displacements**

$h_{ef}$	<b>N</b>	$\delta_{N0}$	$\delta_{N\infty}$	<b>V</b>	$\delta_{V0}$	$\delta_{V\infty}$
[mm]	[kN]	[mm]	[mm]	[kN]	[mm]	[mm]
$\geq 50$	2,5	0,3	0,6	1,8	2,0	3,0

Hilti HIT-HY 270 with HAS-U

Performances solid lightweight concrete brick Vb1, 2DF  
Characteristic values of resistance under tension and shear loads  
Displacements

Annex C18



**Brick type: Solid normal weight concrete brick Vbn, 2DF**

**Table C37: Description of brick**



Brick type			Solid Vbn, 2DF	
Bulk density	$\rho$	[kg/dm <sup>3</sup> ]	$\geq 2,0$	
Compressive strength	$f_b$	[N/mm <sup>2</sup> ]	$\geq 6 / 16$	
Code			EN 771-3	
Producer				
Brick dimensions			[mm] $\geq 240 \times 115 \times 113$	
Minimum wall thickness	$h_{min}$	[mm]	$\geq 115$	

**Characteristic resistances for all anchor combinations (see Table B3)**

**Table C38: Tension resistance at edge distance  $c \geq 115$  mm**

Use category			w/w = w/d		d/d	
Service temperature range			Ta	Tb	Ta	Tb
Anchor type and size	$h_{ef}$ [mm]	$f_b$ [N/mm <sup>2</sup> ]	$N_{Rk,p} = N_{Rk,b}$ [kN]			
All anchor	$\geq 50$	6	3,0	2,5	3,0	2,5
		16	5,5	4,5	5,5	4,5







Related edge and spacing distance and group factor  $\alpha_g$

Configuration	$c \geq$ [mm]	$s_{\perp} \geq$ [mm]	$\alpha_g$ [-]	Configuration	$c \geq$ [mm]	$s_{\parallel} \geq$ [mm]	$\alpha_g$ [-]
	115	-	-	-	-	-	-
	115	$3 h_{ef}$	2,0		115	$3 h_{ef}$	2,0

**Table C39: Tension resistance at edge distance  $c \geq 50$  mm**

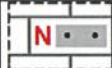
Use category			w/w = w/d		d/d	
Service temperature range			Ta	Tb	Ta	Tb
Anchor type and size	$h_{ef}$ [mm]	$f_b$ [N/mm <sup>2</sup> ]	$N_{Rk,p} = N_{Rk,b}$ [kN]			
All anchor	$\geq 50$	6	1,5	1,2	1,5	1,2
		16	2,5	2,0	2,5	2,0

Related edge and spacing distance and group factor  $\alpha_g$

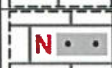
Configuration	$c \geq$ [mm]	$s_{\perp} \geq$ [mm]	$\alpha_g$ [-]	Configuration	$c \geq$ [mm]	$s_{\parallel} \geq$ [mm]	$\alpha_g$ [-]
	50	-	-	-	-	-	-
	50	115	1,0		50	115	1,0
	115	50	1,0		115	50	1,0
	50	$3 h_{ef}$	2,0		50	$3 h_{ef}$	2,0

**Hilti HIT-HY 270 with HAS-U**

**Performances solid normal weight concrete brick Vbn, 2DF**  
Characteristic values of resistance under tension load and group factor

**Annex C19**

**Table C40: Shear resistance at edge distance  $c \geq 115$  mm (for  $V_{II}$ ) and  $c \geq 1,5 h_{ef}$  (for  $V_{\perp}$ )**

Anchor type and size	$h_{ef}$ [mm]	$f_b$ [N/mm <sup>2</sup> ]	$V_{Rk,b} = V_{Rk,c \parallel}$ [kN]	$V_{Rk,c \perp}$
All anchor	$\geq 50$	6	4,0	Calculate according to TR 054 equation 10
		16	6,5	

Related edge and spacing distance and group factor  $\alpha_g$

Configuration	$c \geq$ [mm]	$s_{\perp} \geq$ [mm]	$\alpha_g$ [-]	Configuration	$c \geq$ [mm]	$s_{\perp} \geq$ [mm]	$\alpha_g$ [-]
	115	-	-		1,5 $h_{ef}$	-	-
	115	3 $h_{ef}$	2,0		1,5 $h_{ef}$	3 $h_{ef}$	2,0
Configuration	$c \geq$ [mm]	$s_{\parallel}$ [mm]	$\alpha_g$ [-]	Configuration	$c \geq$ [mm]	$s_{\parallel}$ [mm]	$\alpha_g$ [-]
	115	3 $h_{ef}$	2,0		1,5 $h_{ef}$	3 $h_{ef}$	2,0

**Table C41: Shear resistance at edge distance  $c \geq 50$  mm**

Anchor type and size	$h_{ef}$ [mm]	$f_b$ [N/mm <sup>2</sup> ]	$V_{Rk,b} = V_{Rk,c \parallel} = V_{Rk,c \perp}$
All anchor	$\geq 50$	4	1,5
		6	3,0

Related edge and spacing distance and group factor  $\alpha_g$

Configuration	$c \geq$ [mm]	$s_{\perp} \geq$ [mm]	$\alpha_g$ [-]	Configuration	$c \geq$ [mm]	$s_{\perp} \geq$ [mm]	$\alpha_g$ [-]
	50	-	-		50	-	-
	115	50	1,0		115	50	1,0
	50	115	1,0		50	115	1,0
	50	3 $h_{ef}$	2,0		50	3 $h_{ef}$	2,0
Configuration	$c \geq$ [mm]	$s_{\parallel}$ [mm]	$\alpha_g$ [-]	Configuration	$c \geq$ [mm]	$s_{\parallel}$ [mm]	$\alpha_g$ [-]
	115	50	1,0		115	50	1,0
	50	115	1,0		50	115	1,0
	50	3 $h_{ef}$	2,0		50	3 $h_{ef}$	2,0

**Table C42: Displacements**

$h_{ef}$	<b>N</b>	$\delta_{N0}$	$\delta_{N\infty}$	<b>V</b>	$\delta_{V0}$	$\delta_{V\infty}$
[mm]	[kN]	[mm]	[mm]	[kN]	[mm]	[mm]
$\geq 50$	1,5	0,3	0,6	1,8	2,0	3,0

Hilti HIT-HY 270 with HAS-U

Performances solid normal weight concrete brick Vbn, 2DF  
Characteristic values of resistance under shear load and group factor  
Displacements

Annex C20

**Brick type: Hollow clay brick Hz, 10DF**

**Table C43: Description of brick**

Brick type		Hz12-1,4-10 DF	 <p>Drawing of the brick see <b>Table B4</b></p>
Bulk density	$\rho$ [kg/dm <sup>3</sup> ]	$\geq 1,4$	
Compressive strength	$f_b$ [N/mm <sup>2</sup> ]	$\geq 12 / 20$	
Code		EN 771 - 1	
Producer		Rapis (D)	
Brick dimensions	[mm]	300 x 240 x 238	
Minimum wall thickness	$h_{min}$ [mm]	$\geq 240$	



**Characteristic resistances for all anchor combinations (see Table B3)**

**Table C44: Tension resistance at edge distance  $c \geq 150$  mm**

Use category			w/w = w/d		d/d	
Service temperature range			Ta	Tb	Ta	Tb
Anchor type and size	$h_{ef}$ [mm]	$f_b$ [N/mm <sup>2</sup> ]	$N_{Rk,p} = N_{Rk,b}$ [kN]			
All anchor	$\geq 80$	12	5,5 (6,0*)			
		20	7,0 (8,0*)			

\* Compressed air cleaning only

Related edge and spacing distance and group factor  $\alpha_g$

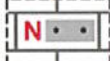



Configuration	$c \geq$ [mm]	$s_{\perp} \geq$ [mm]	$\alpha_g$ [-]	Configuration	$c \geq$ [mm]	$s_{\parallel} \geq$ [mm]	$\alpha_g$ [-]
	150	-	-	-	-	-	-
	150	240	2,0		150	300	2,0

**Table C45: Tension resistance at edge distance  $c \geq 50$  mm**

Use category			w/w = w/d		d/d	
Service temperature range			Ta	Tb	Ta	Tb
Anchor type and size	$h_{ef}$ [mm]	$f_b$ [N/mm <sup>2</sup> ]	$N_{Rk,p} = N_{Rk,b}$ [kN]			
All anchor	$\geq 80$	12	1,5 (2,0*)			
		20	2,0 (2,5*)			

\* Compressed air cleaning only

Related edge and spacing distance and group factor  $\alpha_g$

Configuration	$c \geq$ [mm]	$s_{\perp} \geq$ [mm]	$\alpha_g$ [-]	Configuration	$c \geq$ [mm]	$s_{\parallel} \geq$ [mm]	$\alpha_g$ [-]
	50	-	-	-	-	-	-
	50	5 d <sub>0</sub>	1,0		50	5 d <sub>0</sub>	1,0
	50	240	2,0		50	300	2,0

**Hilti HIT-HY 270 with HAS-U**

**Performances hollow clay brick Hz, 10DF**  
Characteristic values of resistance under tension load and group factor

**Annex C21**

**Table C46: Shear resistance at edge distance  $c \geq 300$  mm**

Anchor type and size	$h_{ef}$ [mm]	$f_b$ [N/mm <sup>2</sup> ]	$V_{Rk,b} = V_{Rk,c,II} = V_{Rk,c,\perp}^{1)}$ [kN]
HAS-U M8, M10	$\geq 80$	12	4,5
		20	5,5
HAS-U M12, M16		12	9,5
		20	10

<sup>1)</sup>  $V_{Rk,b}$  may be used as  $V_{Rk,c,\perp}$  if

- Horizontal joints are completely filled with mortar and
- Vertical joints are completely filled with mortar or the bricks have completely direct contact to each other.

Related edge and spacing distance and group factor  $\alpha_g$

Configuration	$c \geq$ [mm]	$s_{\perp} \geq$ [mm]	$\alpha_g$ [-]	Configuration	$c \geq$ [mm]	$s_{\perp} \geq$ [mm]	$\alpha_g$ [-]
	300	-	-		300	-	-
	300	240	2,0		300	240	1,0
Configuration	$c \geq$ [mm]	$s_{  }$ [mm]	$\alpha_g$ [-]	Configuration	$c \geq$ [mm]	$s_{  }$ [mm]	$\alpha_g$ [-]
	300	300	2,0		300	300	2,0

**Table C47: Shear resistance at edge distance  $c \geq 50$  mm**

Anchor type and size	$h_{ef}$ [mm]	$c$ [mm]	$V_{Rk,c,\perp}$ [kN]
All anchor	$\geq 80$	$\geq 50$	1,25
		$\geq 250$	2,5
		$c$ [mm]	$V_{Rk,b} = V_{Rk,c,II}$ [kN]
		$\geq 50$	1,25
		$\geq 100$ and $\geq 6 \cdot d_0$	2,5

Related edge and spacing distance and group factor  $\alpha_g$

Configuration	$c \geq$ [mm]	$s_{\perp} \geq$ [mm]	$\alpha_g$ [-]	Configuration	$c \geq$ [mm]	$s_{\perp} \geq$ [mm]	$\alpha_g$ [-]
	see table C47	-	-		see table C47	-	-
	see table C47	5 $d_0$	1,0		see table C47	5 $d_0$	1,0
	see table C47	240	2,0		see table C47	240	2,0
Configuration	$c \geq$ [mm]	$s_{  }$ [mm]	$\alpha_g$ [-]	Configuration	$c \geq$ [mm]	$s_{  }$ [mm]	$\alpha_g$ [-]
	see table C47	5 $d_0$	1,0		see table C47	5 $d_0$	1,0
	see table C47	300	2,0		see table C47	300	2,0

**Table C48: Displacements**

$h_{ef}$	<b>N</b>	$\delta_{N0}$	$\delta_{N\infty}$	<b>V</b>	$\delta_{V0}$	$\delta_{V\infty}$
[mm]	[kN]	[mm]	[mm]	[kN]	[mm]	[mm]
$\geq 80$	2,5	0,4	0,8	1,7	1,0	1,5

Hilti HIT-HY 270 with HAS-U

Performances hollow clay brick Hz, 10DF

Characteristic values of resistance under shear load and group factor  
Displacements

Annex C22

**Brick type: Hollow calcium silicate brick KSL, 8DF**

**Table C49: Description of brick**





Brick type		KSL-12-1,4-8 DF	 <p>Drawing of the brick see Table B4</p>
Bulk density	$\rho$ [kg/dm <sup>3</sup> ]	$\geq 1,4$	
Compressive strength	$f_b$ [N/mm <sup>2</sup> ]	$\geq 12 / 20$	
Code		EN 771 – 2	
Producer		KS Wemding (D)	
Brick dimensions	[mm]	248 x 240 x 238	
Minimum wall thickness	$h_{min}$ [mm]	$\geq 240$	

**Characteristic resistances for all anchor combinations (see Table B3)**

**Table C50: Tension resistance at edge distance  $c \geq 50$  mm**

Use category			w/w = w/d		d/d	
Service temperature range			Ta	Tb	Ta	Tb
Anchor type and size	$h_{ef}$ [mm]	$f_b$ [N/mm <sup>2</sup> ]	$N_{RK,p} = N_{RK,b}$ [kN]			
HAS-U M8 to M16	$\geq 80$	12	-	-	4,0	3,0
		20	-	-	5,5	4,5
	$\geq 130$	12	-	-	5,0	4,0
		20	-	-	7,5	6,0

Related edge and spacing distance and group factor  $\alpha_g$

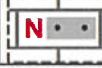
Configuration	$c \geq$ [mm]	$s_{\perp} \geq$ [mm]	$\alpha_g$ [-]	Configuration	$c \geq$ [mm]	$s_{  } \geq$ [mm]	$\alpha_g$ [-]
	50	-	-	-	-	-	-
	50	50	1,0		50	50	1,0
	50	240	2,0		50	250	2,0

**Table C51: Shear resistance at edge distance  $c \geq 125$  mm (for  $V_{||}$ ) and  $c \geq 250$  mm (for  $V_{\perp}$ )**

Anchor type and size	$h_{ef}$ [mm]	$f_b$ [N/mm <sup>2</sup> ]	$V_{RK,b} = V_{RK,c  } = V_{RK,c\perp}^{1)}$ [kN]
HAS-U M8	$\geq 80$	12	6,0
		20	9,0
HAS-U M10		12	9,0
		20	12,0
HAS-U M12 to M16		12	12,0
		20	12,0

<sup>1)</sup>  $V_{RK,b}$  may be used as  $V_{RK,c\perp}$  if  
 - Horizontal joints are completely filled with mortar and  
 - Vertical joints are completely filled with mortar or the bricks have completely direct contact to each other and  
 - max  $V_{RK,c\perp} = 9$  kN

**Hilti HIT-HY 270 with HAS-U**

**Performances hollow silica brick KSL, 8DF**  
 Characteristic values of resistance under tension and shear load and group factor

**Annex C23**

Related edge and spacing distance and group factor  $\alpha_g$

Configuration	$c \geq$ [mm]	$s_{\perp} \geq$ [mm]	$\alpha_g$ [-]	Configuration	$c \geq$ [mm]	$s_{\perp} \geq$ [mm]	$\alpha_g$ [-]
	125	-	-		250	-	-
	125	240	2,0	-	-	-	-
Configuration	$c \geq$ [mm]	$s_{\parallel}$ [mm]	$\alpha_g$ [-]	Configuration	$c \geq$ [mm]	$s_{\parallel}$ [mm]	$\alpha_g$ [-]
	125	250	2,0		250	250	2,0

**Table C52: Shear resistance at edge distance  $c \geq 50$  mm**

Anchor type and size	$h_{ef}$ [mm]	$c$ [mm]	$f_b$ [N/mm <sup>2</sup> ]	$V_{Rk,c,\perp}^{1)}$ [kN]
All anchor	$\geq 80$	$\geq 50$	12	4,0
			20	6,0
		$c$ [mm]	$f_b$ [N/mm <sup>2</sup> ]	$V_{Rk,b} = V_{Rk,c,\parallel}$ [kN]
			$\geq 50$	12
		20	6,0	

Related edge and spacing distance and group factor  $\alpha_g$

Configuration	$c \geq$ [mm]	$s_{\perp} \geq$ [mm]	$\alpha_g$ [-]	Configuration	$c \geq$ [mm]	$s_{\perp} \geq$ [mm]	$\alpha_g$ [-]
	50	-	-		50	-	-
	50	50	1,0		50	50	1,0
	50	240	2,0		50	240	2,0
Configuration	$c \geq$ [mm]	$s_{\parallel}$ [mm]	$\alpha_g$ [-]	Configuration	$c \geq$ [mm]	$s_{\parallel}$ [mm]	$\alpha_g$ [-]
	50	50	1,0		50	50	1,0
	50	250	2,0		50	250	2,0

<sup>1)</sup> max  $V_{Rk,c,\perp} = 9$  kN

**Table C53: Displacements**

$h_{ef}$	<b>N</b>	$\delta_{N0}$	$\delta_{N\infty}$	<b>V</b>	$\delta_{V0}$	$\delta_{V\infty}$
[mm]	[kN]	[mm]	[mm]	[kN]	[mm]	[mm]
80	1,0	0,3	0,6	4,3	2,0	3,0
130	2,1	0,3	0,6	4,3	2,0	3,0

Hilti HIT-HY 270 with HAS-U

Performances hollow silica brick KSL, 8DF

Characteristic values of resistance under shear load and group factor  
Displacements

Annex C24

**Brick type: Hollow lightweight concrete brick Hbl, 16DF**

**Table C54: Description of brick**

Brick type		Hbl-4-0,7	 <p>Drawing of the brick see <b>Table B4</b></p>
Bulk density	$\rho$ [kg/dm <sup>3</sup> ]	$\geq 0,7$	
Compressive strength	$f_b$ [N/mm <sup>2</sup> ]	$\geq 2 / 6$	
Code		EN 771-3	
Producer		Knobel (D)	
Brick dimensions	[mm]	495 x 240 x 238	
Minimum wall thickness	$h_{\min}$ [mm]	$\geq 240$	



**Characteristic resistances for all anchor combinations (see Table B3)**

**Table C55: Tension resistance at edge distance  $c \geq 125$  mm**

Use category			w/w = w/d		d/d	
Service temperature range			Ta	Tb	Ta	Tb
Anchor type and size	$h_{ef}$ [mm]	$f_b$ [N/mm <sup>2</sup> ]	$N_{Rk,p} = N_{Rk,b}$ [kN]			
HAS-U M8 and M10,	$\geq 80$	2	3,5	3,0	4,0	3,0 (3,5*)
		6	6,0	5,0	6,5 (7,0*)	5,5 (6,0*)
HAS-U M12 and M16	$\geq 80$	2	4,0	3,5	4,5	3,5 (4,0*)
		6	7,0	6,0	8,0	6,5 (7,0*)

\* Compressed air cleaning only

Related edge and spacing distance and group factor  $\alpha_g$

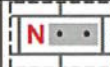
Configuration	$c \geq$ [mm]	$s_{\perp} \geq$ [mm]	$\alpha_g$ [-]	Configuration	$c \geq$ [mm]	$s_{\parallel} \geq$ [mm]	$\alpha_g$ [-]
	125	-	-	-	-	-	-
	125	240	2,0		125	240	2,0

**Hilti HIT-HY 270 with HAS-U**

**Performances hollow lightweight concrete brick Hbl, 16DF**  
Characteristic values of resistance under tension load and group factor

**Annex C25**

**Table C56: Tension resistance at edge distance  $c \geq 50$  mm**

Use category			w/w = w/d		d/d	
Service temperature range			Ta	Tb	Ta	Tb
Anchor type and size	$h_{ef}$ [mm]	$f_b$ [N/mm <sup>2</sup> ]	$N_{Rk,p} = N_{Rk,b}$ [kN]			
HAS-U M8 to M16	$\geq 80$	2	1,5	1,2	1,5	1,5
		6	2,5	2,0	3,0	2,5
	160	2	2,0	1,5	2,0	1,5 (2,0*)
		6	3,5	2,5	3,5 (4,0*)	3,0

\* Compressed air cleaning only

Related edge and spacing distance and group factor  $\alpha_g$

Configuration	$c \geq$ [mm]	$s_{\perp} \geq$ [mm]	$\alpha_g$ [-]	Configuration	$c \geq$ [mm]	$s_{\parallel} \geq$ [mm]	$\alpha_g$ [-]
	50	-	-	-	-	-	-
	50	50	1,0		50	50	1,0
	50	240	2,0		50	240	2,0

**Table C57: Shear resistance at edge distance  $c \geq 250$  mm (for  $V_{\parallel}$ ) and  $c \geq 500$  mm (for  $V_{\perp}$ )**

Anchor type and size	$h_{ef}$ [mm]	$f_b$ [N/mm <sup>2</sup> ]	$V_{Rk,b} = V_{Rk,c \parallel} = V_{Rk,c \perp}$ <sup>1)</sup> [kN]
HAS-U M8, M10	$\geq 80$	2	4,0
		6	6,5
HAS-U M12	$\geq 80$	2	5,5
		6	9,5
HAS-U M16	$\geq 80$	2	6,0
		6	10,0

<sup>1)</sup>  $V_{Rk,b}$  may be used as  $V_{Rk,c \perp}$  if

- Horizontal joints are completely filled with mortar and
- Vertical joints are completely filled with mortar or the bricks have completely direct contact to each other.

Related edge and spacing distance and group factor  $\alpha_g$

Configuration	$c \geq$ [mm]	$s_{\perp} \geq$ [mm]	$\alpha_g$ [-]	Configuration	$c \geq$ [mm]	$s_{\perp} \geq$ [mm]	$\alpha_g$ [-]
	250	-	-		500	-	-
	250	240	2,0		500	240	1,0
Configuration	$c \geq$ [mm]	$s_{\parallel}$ [mm]	$\alpha_g$ [-]	Configuration	$c \geq$ [mm]	$s_{\parallel}$ [mm]	$\alpha_g$ [-]
	250	250	2,0		500	500	2,0

Hilti HIT-HY 270 with HAS-U

Performances hollow lightweight concrete brick Hbl, 16DF  
Characteristic values of resistance under tension and shear load and group factor







Annex C26

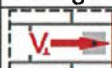

**Table C58: Shear resistance at edge distance  $c \geq 50$  mm**

Anchor type and size	$h_{ef}$ [mm]	$c$ [mm]	$f_b$ [N/mm <sup>2</sup> ]	$V_{Rk,c,\perp}$ [kN]
All anchor	$\geq 80$	$\geq 50$	2	1,5
			6	3,0
		$\geq 250$	2	2,5
			$c$ [mm]	$f_b$ [N/mm <sup>2</sup> ]
		$\geq 50$	2	1,5
			6	3,0
$\geq 100$ $\geq 6 d_0$	2	2,5		

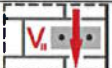
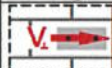
Related edge and spacing distance and group factor  $\alpha_g$

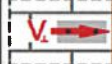
Configuration	$c \geq$ [mm]	$s_{\perp} \geq$ [mm]	$\alpha_g$ [-]	Configuration	$c \geq$ [mm]	$s_{\perp} \geq$ [mm]	$\alpha_g$ [-]
	see table C58	-	-		see table C58	-	-
	see table C58	50	1,0		see table C58	50	1,0
	see table C58	240	2,0		see table C58	240	2,0
Configuration	$c \geq$ [mm]	$s_{  }$ [mm]	$\alpha_g$ [-]	Configuration	$c \geq$ [mm]	$s_{  }$ [mm]	$\alpha_g$ [-]
	see table C58	50	1,0		see table C58	50	1,0
	see table C58	250	2,0		see table C58	250	2,0

**Table C59: Displacements**

$h_{ef}$	N	$\delta_{N0}$	$\delta_{N\infty}$	V	$\delta_{V0}$	$\delta_{V\infty}$
[mm]	[kN]	[mm]	[mm]	[kN]	[mm]	[mm]
80	0,8	0,20	0,4	2,3	1,0	1,5
160	1,1	0,25	0,5	2,3	1,0	1,5

Hilti HIT-HY 270 with HAS-U

Performances hollow lightweight concrete brick Hbl, 16DF  
Characteristic values of resistance under shear load and group factor  
Displacements

Annex C27

**Brick type: Hollow normal weight concrete brick - parpaing creux**

**Table C60: Description of brick**



Brick type		B40	 <p>Drawing of the brick see <b>Table B4</b></p>
Bulk density	$\rho$ [kg/dm <sup>3</sup> ]	$\geq 0,9$	
Compressive strength	$f_b$ [N/mm <sup>2</sup> ]	$\geq 4 / 10$	
Code		EN 771-3	
Producer		Fabemi (F)	
Brick dimensions	[mm]	500 x 200 x 200	
Minimum wall thickness	$h_{min}$ [mm]	$\geq 200$	

**Characteristic resistances for all anchor combinations (see Table B3)**

**Table C61: Tension resistance at edge distance  $c \geq 50$  mm**

Use category			w/w = w/d		d/d	
Service temperature range			Ta	Tb	Ta	Tb
Anchor type and size	$h_{ef}$ [mm]	$f_b$ [N/mm <sup>2</sup> ]	$N_{RK,p} = N_{RK,b}$ [kN]			
All anchors	$\geq 50$	4	0,9	0,9	0,9	0,9
		10	2,0	1,5	2,0	1,5
All anchors	$\geq 130$	4	1,5	1,2	1,5	1,2
		10	2,5	2,0	2,5	2,0

Related edge and spacing distance and group factor  $\alpha_g$

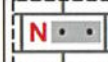
Configuration	$c \geq$ [mm]	$s_{\perp} \geq$ [mm]	$\alpha_g$ [-]	Configuration	$c \geq$ [mm]	$s_{\perp} \geq$ [mm]	$\alpha_g$ [-]
	50	-	-	-	-	-	-
	50	200	2,0		50	200	2,0

**Table C62: Shear resistance at edge distance  $c \geq 200$  mm (for  $V_{||}$ ) and  $c \geq 500$  mm (for  $V_{\perp}$ )**

Anchor type and size	$h_{ef}$ [mm]	$f_b$ [N/mm <sup>2</sup> ]	$V_{RK,b} = V_{RK,c  } = V_{RK,c\perp}^{1)}$ [kN]
All anchors	$\geq 50$	4	4
		10	6,5
	$\geq 80$	4	5
		10	7,5

<sup>1)</sup>  $V_{RK,b}$  may be used as  $V_{RK,c\perp}$  if







- Horizontal joints are completely filled with mortar and
- Vertical joints are completely filled with mortar or the bricks have completely direct contact to each other.

**Hilti HIT-HY 270 with HAS-U**

**Performances hollow normal weight concrete brick - parpaing creux**  
Characteristic values of resistance under tension and shear load and group factor

**Annex C28**

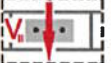





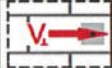

Related edge and spacing distance and group factor  $\alpha_g$

Configuration	$c \geq$ [mm]	$s_{\perp} \geq$ [mm]	$\alpha_g$ [-]	Configuration	$c \geq$ [mm]	$s_{\perp} \geq$ [mm]	$\alpha_g$ [-]
	200	-	-		500	-	-
	200	200	2,0		500	200	1,0
Configuration	$c \geq$ [mm]	$s_{\parallel}$ [mm]	$\alpha_g$ [-]	Configuration	$c \geq$ [mm]	$s_{\parallel}$ [mm]	$\alpha_g$ [-]
	200	200	2,0		500	500	2,0

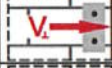
**Table C63: Shear resistance at edge distance  $c \geq 50$  mm**

Anchor type and size	$h_{ef}$ [mm]	$c$ [mm]	$f_b$ [N/mm <sup>2</sup> ]	$V_{Rk,c,\perp}$ [kN]
All anchor	$\geq 50$	$\geq 50$	4	1,2
			10	1,5
		$\geq 250$	4/10	2,5
		$c$ [mm]	$f_b$ [N/mm <sup>2</sup> ]	$V_{Rk,b} = V_{Rk,c,\parallel}$ [kN]
		$\geq 50$	4	2,0
		$\geq 50$	10	3,0

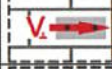
Related edge and spacing distance and group factor  $\alpha_g$

Configuration	$c \geq$ [mm]	$s_{\perp} \geq$ [mm]	$\alpha_g$ [-]	Configuration	$c \geq$ [mm]	$s_{\perp} \geq$ [mm]	$\alpha_g$ [-]
	50	-	-		see table C63	-	-
	50	50	1,0		see table C63	50	1,0
	50	200	2,0		see table C63	200	2,0
Configuration	$c \geq$ [mm]	$s_{\parallel}$ [mm]	$\alpha_g$ [-]	Configuration	$c \geq$ [mm]	$s_{\parallel}$ [mm]	$\alpha_g$ [-]
	50	50	1,0		see table C63	50	1,0
	50	200	2,0		see table C63	200	2,0

**Table C64: Displacements**

$h_{ef}$	<b>N</b>	$\delta_{N0}$	$\delta_{N\infty}$	<b>V</b>	$\delta_{V0}$	$\delta_{V\infty}$
[mm]	[kN]	[mm]	[mm]	[kN]	[mm]	[mm]
$\geq 50$	0,7	0,5	1,0	1,7	1,0	1,5

Hilti HIT-HY 270 with HAS-U

Performances hollow normal weight concrete brick - parpaing creux  
Characteristic values of resistance under shear load and group factor  
Displacements

Annex C29

**Brick type: Hollow clay brick for ceiling**

**Table C65: Description of brick**

Brick type		Ds-1,0	 Drawing of the brick see <b>Table B4</b>
Bulk density	$\rho \geq$ [kg/dm <sup>3</sup> ]	1,0	
Strength		DIN EN 15037-3, class R2	
Code		DIN 4160	
Producer		Fiedler Marktredwitz (D)	
Brick dimensions	[mm]	510 x 250 x 180	
Min. ceiling thickness	$h_{\min} \geq$ [mm]	$\geq 180$	

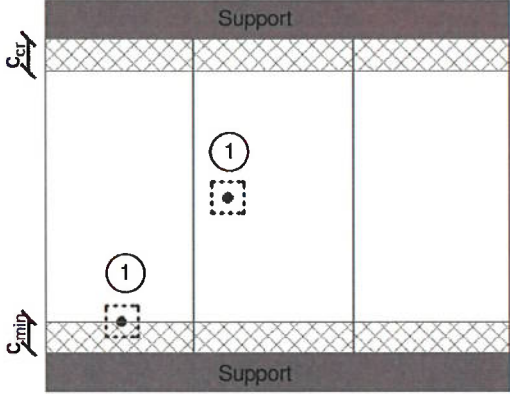
	① Single fastening Maximum one anchor per ceiling brick
--	--

**Table C66: Installation parameter for all anchor combinations (see Table B3)**

Anchor type		HAS-U M6 with HIT-SC 12x85
Edge distance	$c_{\min} = c_{cr}$ [mm]	100 from support
Spacing $A_c$	$s_{\min II}$ [mm]	510
	$s_{\min \perp} = s_{cr}$ [mm]	250

**Table C67: Group factor**

Group factor	$\alpha_{g,N II} \alpha_{g,V II} \alpha_{g,N \perp} \alpha_{g,V \perp}$ [-]	1
--------------	---	---

**Table C68: Characteristic tension resistance for all anchor combinations (see Table B3)**

Use category			w/w		d/d	
Service temperature range			Ta	Tb	Ta	Tb
Anchor type and size	$h_{ef}$ [mm]	Console load capacity [kN]	$N_{Rk,p} = N_{Rk,b}$ [kN]			
All anchor	$\geq 80$	3	1,5	1,5	1,5	1,5

**Table C69: Displacements**

$h_{ef}$	N	$\delta_{N0}$	$\delta_{N\infty}$
[mm]	[kN]	[mm]	[mm]
$\geq 80$	0,4	0,15	0,30

Hilti HIT-HY 270 with HAS-U

Performances hollow clay brick for ceiling  
Characteristic values of resistance under tension load  
Displacements

Annex C30



Zulassungsstelle für Bauprodukte und Bauarten

Bautechnisches Prüfamt

Eine vom Bund und den Ländern  
gemeinsam getragene Anstalt des öffentlichen Rechts

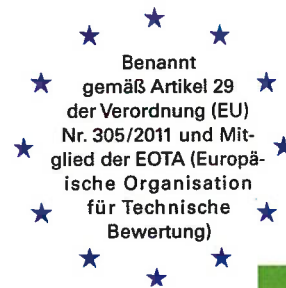

## Europäische Technische Bewertung

ETA-19/0160  
vom 30. August 2019

### Allgemeiner Teil

Technische Bewertungsstelle, die  
die Europäische Technische Bewertung  
ausstellt

Handelsname des Bauprodukts

Produktfamilie,  
zu der das Bauprodukt gehört

Hersteller

Herstellungsbetrieb

Diese Europäische Technische Bewertung  
enthält

Diese Europäische Technische Bewertung  
wird ausgestellt gemäß der Verordnung (EU)  
Nr. 305/2011, auf der Grundlage von

Diese Fassung ersetzt

Deutsches Institut für Bautechnik

Hilti HIT-HY 270 mit HAS-U

Metall-Injektionsdübel zur Verankerung im Mauerwerk

Hilti Aktiengesellschaft  
9494 SCHAAN  
FÜRSTENTUM LIECHTENSTEIN

Hilti Werke

51 Seiten, davon 3 Anhänge, die fester Bestandteil dieser  
Bewertung sind.

EAD 330076-00-0604

ETA-19/0160 vom 29. April 2019

Die Europäische Technische Bewertung wird von der Technischen Bewertungsstelle in ihrer Amtssprache ausgestellt. Übersetzungen dieser Europäischen Technischen Bewertung in andere Sprachen müssen dem Original vollständig entsprechen und müssen als solche gekennzeichnet sein.

Diese Europäische Technische Bewertung darf, auch bei elektronischer Übermittlung, nur vollständig und ungekürzt wiedergegeben werden. Nur mit schriftlicher Zustimmung der ausstellenden Technischen Bewertungsstelle kann eine teilweise Wiedergabe erfolgen. Jede teilweise Wiedergabe ist als solche zu kennzeichnen.

Die ausstellende Technische Bewertungsstelle kann diese Europäische Technische Bewertung widerrufen, insbesondere nach Unterrichtung durch die Kommission gemäß Artikel 25 Absatz 3 der Verordnung (EU) Nr. 305/2011.

## Besonderer Teil

### 1 Technische Beschreibung des Produkts

Das Injektionssystem Hilti HIT-HY 270 mit HAS-U für Mauerwerk ist ein Verbunddübel (Injektionstyp), der aus einem Foliengebinde mit Injektionsmörtel Hilti HIT-HY 270, einer Siebhülse und einer Gewindestange mit Sechskanmutter und Unterlegscheibe in den Größen M6 bis M16 besteht. Die Stahlteile bestehen aus verzinktem Stahl, nichtrostendem Stahl oder hochkorrosionsbeständigem Stahl.

Die Ankerstange wird in ein mit Injektionsmörtel gefülltes Bohrloch gesetzt und durch den Verbund und/oder Formschluss zwischen Stahlteil, Injektionsmörtel und Mauerwerk verankert.

Die Produktbeschreibung ist in Anhang A angegeben.

### 2 Spezifizierung des Verwendungszwecks gemäß dem anwendbaren Europäischen Bewertungsdokument

Von den Leistungen in Abschnitt 3 kann nur ausgegangen werden, wenn der Dübel entsprechend den Angaben und Bedingungen nach Anhang B verwendet wird.

Die Prüf- und Bewertungsmethoden, die dieser Europäischen Technischen Bewertung zu Grunde liegen, führen zur Annahme einer Nutzungsdauer des Dübels von mindestens 50 Jahren. Die Angabe zur Nutzungsdauer kann nicht als Garantie des Herstellers ausgelegt werden, sondern ist lediglich ein Hilfsmittel zur Auswahl des richtigen Produkts in Bezug auf die erwartete wirtschaftlich angemessene Nutzungsdauer des Bauwerks.

### 3 Leistung des Produkts und Angaben der Methoden ihrer Bewertung

#### 3.1 Mechanische Festigkeit und Standsicherheit (BWR 1)

Wesentliches Merkmal	Leistung
Charakteristische Werte für Widerstand	Siehe Anhang C1 bis C30
Verschiebungen	Siehe Anhang C4 bis C30
Dauerhaftigkeit	Siehe Anhang B2

#### 3.2 Brandschutz (BWR 2)

Wesentliches Merkmal	Leistung
Brandverhalten	Klasse A1

#### 3.3 Hygiene, Gesundheit und Umweltschutz (BWR 3)

Wesentliches Merkmal	Leistung
Inhalt, Emission und/oder Freisetzung von gefährlichen Stoffen	Leistung nicht bewertet

### 4 Angewandtes System zur Bewertung und Überprüfung der Leistungsbeständigkeit mit der Angabe der Rechtsgrundlage

Gemäß dem Europäischen Bewertungsdokument EAD 330076-00-0604 gilt folgende Rechtsgrundlage: [97/177/EG].

Folgendes System ist anzuwenden: 1



**5 Für die Durchführung des Systems zur Bewertung und Überprüfung der Leistungsbeständigkeit erforderliche technische Einzelheiten gemäß anwendbarem Europäischen Bewertungsdokument**

Technische Einzelheiten, die für die Durchführung des Systems zur Bewertung und Überprüfung der Leistungsbeständigkeit notwendig sind, sind Bestandteil des Prüfplans, der beim Deutschen Institut für Bautechnik hinterlegt ist.

Ausgestellt in Berlin am 30. August 2019 vom Deutschen Institut für Bautechnik

BD Dipl.-Ing. Andreas Kummerow  
Abteilungsleiter



**Einbauzustand**

**Bild A1:** Lochstein und Vollstein mit HAS-U-... und einer Siebhülse HIT-SC (siehe Tabelle B5)

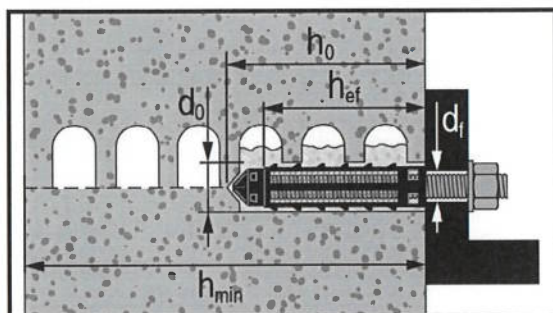

**Bild A2:** Lochstein und Vollstein mit HAS-U-... und zwei Siebhülsen HIT-SC für große Verankerungstiefe (siehe Tabelle B6)

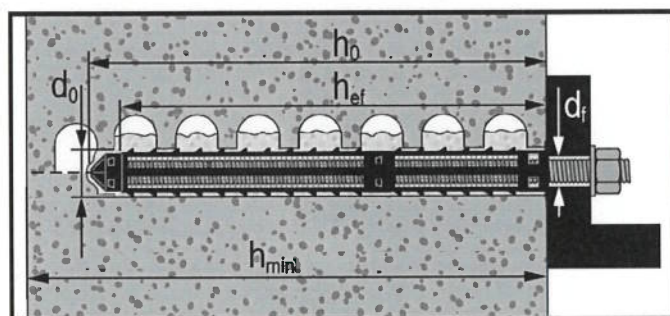

**Bild A3:** Vollstein mit HAS-U-... (siehe Tabelle B7)

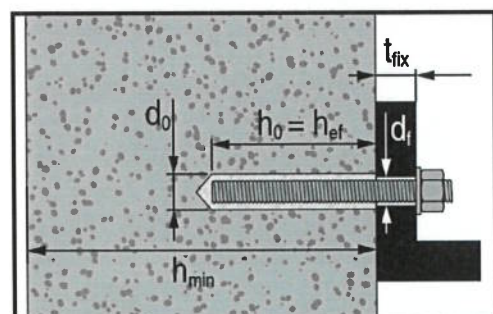

Hilti HIT-HY 270 mit HAS-U

Produktbeschreibung  
Einbauzustand

Anhang A1

**Bild A4:** Lochstein und Vollstein mit HAS-U... mit zwei Siebhülsen HIT-SC zur Montage durch das Anbauteil und/oder durch eine nichttragende Schicht (siehe Tabelle B8)

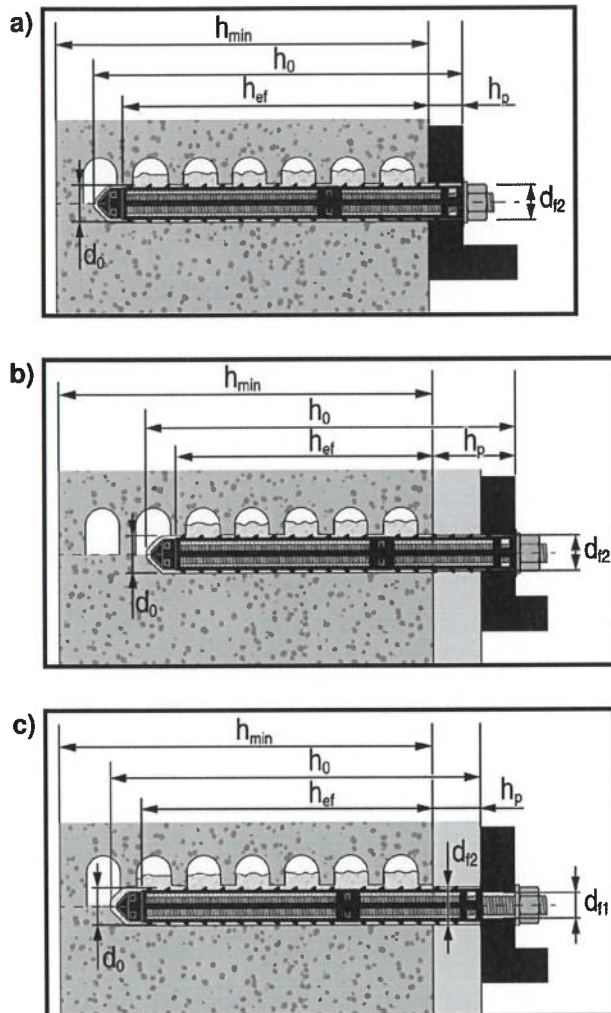

Hilti HIT-HY 270 mit HAS-U

Produktbeschreibung  
Einbauzustand

Anhang A2

### Produktbeschreibung: Injektionsmörtel und Stahlelemente

**Injektionsmörtel Hilti HIT-HY 270:** Hybridsystem mit Zuschlag  
330 ml und 500 ml

Kennzeichnung  
HILTI HY-270  
Chargennummer und  
Produktionslinie  
Verfallsdatum mm/yyyy



Produktname: "Hilti HIT-HY 270"

### Statikmischer Hilti HIT-RE-M



### HAS-U-...

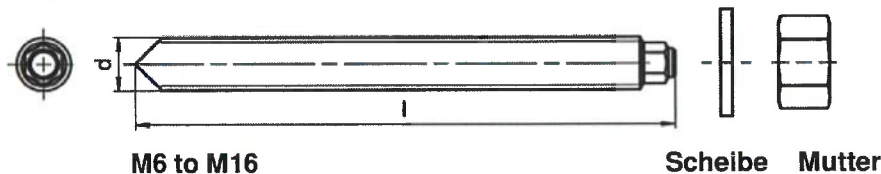

### Siebhülse HIT-SC 16 bis 22

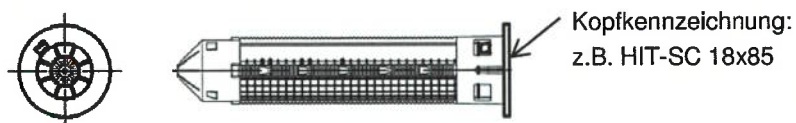

**Hilti HIT-HY 270 mit HAS-U**

**Produktbeschreibung**  
Injektionsmörtel / Statikmischer / Stahlelemente / Siebhülsen

**Anhang A3**

**Tabelle A1: Werkstoffe**

Bezeichnung	Werkstoff
<b>Stahlteile aus verzinktem Stahl</b>	
HAS-U-5.8 (HDG)	Festigkeitsklasse 5.8, $f_{uk} = 500 \text{ N/mm}^2$ , $f_{yk} = 400 \text{ N/mm}^2$ , Bruchdehnung ( $l_0=5d$ ) > 8% duktil Galvanisch verzinkt $\geq 5 \mu\text{m}$ , (HDG) Feuerverzinkt $\geq 45 \mu\text{m}$
HAS-U-8.8 (HDG)	Festigkeitsklasse 8.8, $f_{uk} = 800 \text{ N/mm}^2$ , $f_{yk} = 640 \text{ N/mm}^2$ , Bruchdehnung ( $l_0=5d$ ) > 12% duktil Galvanisch verzinkt $\geq 5 \mu\text{m}$ , (HDG) Feuerverzinkt $\geq 45 \mu\text{m}$
Scheibe	Galvanisch verzinkt $\geq 5 \mu\text{m}$ Feuerverzinkt $\geq 45 \mu\text{m}$
Mutter	Festigkeit der Sechskantmutter abgestimmt auf Festigkeit der Gewindestange Galvanisch verzinkt $\geq 5 \mu\text{m}$ , Feuerverzinkt $\geq 45 \mu\text{m}$
<b>Stahlteile aus nichtrostendem Stahl</b>	
HAS-U A4	Festigkeitsklasse 70, $f_{uk} = 700 \text{ N/mm}^2$ , $f_{yk} = 450 \text{ N/mm}^2$ , Bruchdehnung ( $l_0=5d$ ) > 8% duktil Nichtrostender Stahl A4 gemäß EN 10088-1: 2014
Scheibe	Nichtrostender Stahl A4 gemäß EN 10088-1: 2014
Mutter	Festigkeit der Sechskantmutter abgestimmt auf Festigkeit der Gewindestange Nichtrostender Stahl A4 gemäß EN 10088-1: 2014
<b>Stahlteile aus hochkorrosionsbeständigem Stahl</b>	
HAS-U HCR	$f_{uk} = 800 \text{ N/mm}^2$ , $f_{yk} = 640 \text{ N/mm}^2$ , Bruchdehnung ( $l_0=5d$ ) > 8% duktil Hochkorrosionsbeständiger Stahl gemäß EN 10088-1: 2014
Scheibe	Hochkorrosionsbeständiger Stahl gemäß EN 10088-1: 2014
Mutter	Festigkeit der Sechskantmutter abgestimmt auf Festigkeit der Gewindestange Hochkorrosionsbeständiger Stahl gemäß EN 10088-1: 2014
<b>Plastikteile</b>	
Siebhülse HIT-SC	Rahmen: FPP 20T Netz: PA6.6 N500/200

**Hilti HIT-HY 270 mit HAS-U**

**Produktbeschreibung**  
Werkstoffe

**Anhang A4**

## Spezifizierung des Verwendungszwecks

### Verankerungsgrund:

- Vollsteinmauerwerk (Nutzungskategorie b), entsprechend Anlage B3.  
Bemerkung: Die charakteristischen Widerstände gelten ebenfalls für größere Steinabmessungen und höhere Steindruckfestigkeiten.
- Lochsteinmauerwerk (Nutzungskategorie c), entsprechend Anlage B3 und B5.
- Festigkeitsklasse des Mauer Mörtels: M2,5 Minimum entsprechend EN 998-2: 2010.
- Für Mauerwerk aus anderen Vollsteinen oder Lochsteinen darf der charakteristische Widerstand mittels Baustellenversuchen ermittelt werden. Dies geschieht gemäß EOTA Technical Report TR 053, April 2016, unter Berücksichtigung des im Anhang C1, Tabelle C1 genannten  $\beta$ -Faktors.

### Tabelle B1: Übersicht der Nutzungskategorien

Befestigungen unter:		HIT-HY 270 mit HAS-U	
		in Vollstein	in Lochstein
Bohren 		Hammerbohren, Drehbohren	Drehbohren
Statische und quasi statische Belastung		Anhang : C1 (Stahl), C3 bis C20	Anhang : C1 (Stahl), C21 bis C30
Nutzungskategorie: trockenes oder feuchtes Mauerwerk		Kategorie <b>d/d</b> – <b>Montage und Verwendung</b> in Bauteilen unter den Bedingungen <b>trockener</b> Innenräume. Kategorie <b>w/d</b> – <b>Montage</b> unter <b>trockenen</b> oder <b>feuchten</b> Bedingungen <b>und Verwendung</b> unter den Bedingungen <b>trockener</b> Innenräume (ausgenommen Kalksandsteine). Kategorie <b>w/w</b> - <b>Montage und Verwendung</b> in Bauteilen unter <b>trockenen</b> oder <b>feuchten</b> Bedingungen (ausgenommen Kalksandsteine).	
Montagerichtung Mauerwerk		Horizontal	
Montagerichtung Deckenziegel		Überkopf	
Nutzungskategorie		b ( Mauerwerk aus Vollstein)	c (Mauerwerk aus Lochstein)
Temperatur im Verankerungs- grund beim Einbau		+5° C bis +40° C (Tabelle B9)	0° C bis +40° C (Tabelle B10)
Gebrauchs- temperatur	Temperatur- bereich Ta:	-40 °C bis +40 °C	(max. Langzeittemperatur +24 °C und max. Kurzzeittemperatur +40 °C)
	Temperatur- bereich Tb:	-40 °C bis +80 °C	(max. Langzeittemperatur +50 °C und max. Kurzzeittemperatur +80 °C)

Hilti HIT-HY 270 mit HAS-U

Verwendungszweck  
Spezifikationen

Anhang B1

#### Anwendungsbedingungen (Umweltbedingungen):

- In Bauteilen unter den Bedingungen trockener Innenräume (verzinkter Stahl, nichtrostender Stahl oder hochkorrosionsbeständiger Stahl).
- Bauteile im Freien (einschließlich Industrieatmosphäre und Meeresnähe) und in Feuchträumen, wenn keine besonders aggressiven Bedingungen vorliegen (nichtrostender Stahl oder hochkorrosionsbeständiger Stahl).
- Bauteile im Freien und in Feuchträumen, wenn besonders aggressive Bedingungen vorliegen (hochkorrosionsbeständiger Stahl).  
Anmerkung: Aggressive Bedingungen sind z.B. ständiges, abwechselndes Eintauchen in Meerwasser oder der Bereich der Spritzzone von Meerwasser, chlorhaltige Atmosphäre in Schwimmbadhallen oder Atmosphäre mit extremer chemischer Verschmutzung (z. B. bei Rauchgas-Entschwefelungsanlagen oder Straßentunneln, in denen Enteisungsmittel verwendet werden).

#### Bemessung:

- Die Befestigungen müssen unter der Verantwortung eines auf dem Gebiet der Verankerungen und des Mauerwerksbaus erfahrenen Ingenieurs bemessen werden.
- Unter Berücksichtigung der zu verankernden Lasten sind prüfbare Berechnungen und Konstruktionszeichnungen anzufertigen. Auf den Konstruktionszeichnungen ist die Lage des Dübels (z. B. Lage des Dübels zu den Auflagern usw.) anzugeben.
- Die Bemessung der Verankerungen unter statischer und quasi statischer Belastung erfolgt in Übereinstimmung mit: EOTA Technical Report TR 054, April 2016, Bemessungsverfahren A
- Im Falle, dass die Steindruckfestigkeit  $f_b$  kleiner ist als die höchste, in den Lasttabellen genannte Druckfestigkeit, kann die Last gemäß folgender Formel berechnet werden:

$$F_{Rk,act.} = F_{Rk,ETA,(fb)} * (f_{b,act.}/f_{b,ETA})^\alpha$$

$F_{Rk,act.}$  = Tragfähigkeit des Dübels im vorhandenen Mauerwerk.

$F_{Rk,ETA,(fb)}$  = Tragfähigkeit des Dübels im Mauerwerk gemäß Anhang C3 bis C30.

$f_{b,act.}$  = Vorhandene, normalisierte mittlere Druckfestigkeitsklasse gemäß EN 772-1:2011.

$f_{b,ETA}$  = Normalisierte mittlere Druckfestigkeitsklasse gemäß Anhang C3 bis C30.

$\alpha$  = 0,5 für Mauerwerk aus Ziegel, Beton und Kalksandvollsteinen.

$\alpha$  = 0,75 für Mauerwerk aus Kalksandlochsteinen.

- Für Lochsteinmauerwerk: Querlasten zum freien Rand müssen über vollvermörtelte Stoßfugen oder direkten Kontakt der Steine übertragen werden.
- Für Lochsteinmauerwerk sind nur Querlasten ohne Hebelarm erlaubt.

#### Einbau:

- Der Einbau erfolgt durch entsprechend geschultes Personal unter der Aufsicht des Bauleiters.

Hilti HIT-HY 270 mit HAS-U

Verwendungszweck  
Spezifikationen

Anhang B2

**Tabelle B2: Übersicht der Mauersteine und Eigenschaften**

Art des Mauersteins	Foto	Stein- abmessungen [mm]	Druck- festigkeit $f_{b,ETA}$ [N/mm <sup>2</sup> ]	Roh- dichte [kg/dm <sup>3</sup> ]	Anhang
Vollziegel EN 771-1		≥ 240x115x52	12/20/40	2,0	C3/C4
Vollziegel EN 771-1		≥ 240x115x72	10/20	2,0	C5/C7
Vollziegel EN 771-1		≥ 240x115x113	12/20	2,0	C8/C10
Kalksandvollstein EN 771-2		≥ 240x115x113	12 / 28	2,0	C11/C12
Kalksandvollstein EN 771-2		≥ 248x240x248	12/20/28	2,0	C13/C16
Leichtbetonvollstein EN 771-3		≥ 240x115x113	4 / 6	0,9	C17/C18
Normalbetonvollstein EN 771-3		≥ 240x115x113	6 / 16	2,0	C19/C20
Lochziegel EN 771-1		300x240x238	12 / 20	1,4	C21/C22
Kalksandlochstein EN 771-2		248x240x248	12 / 20	1,4	C23/C24
Leichtbeton Hohlblockstein EN 771-3		495x240x238	2 / 6	0,7	C25/C27
Normalbeton Lochstein EN 771-3		500x200x200	4 / 10	0,9	C28/C29
Lochziegel EN 771-1 Deckenstein		250x510x180	DIN EN 15037-3 Klasse R2	1,0	C30

**Hilti HIT-HY 270 mit HAS-U**

**Verwendungszweck**  
Steintypen und Eigenschaften

**Anhang B3**



**Tabelle B3: Übersicht Befestigungselemente (inkl. Größen und Verankerungstiefen) und zugehörige Mauersteine**







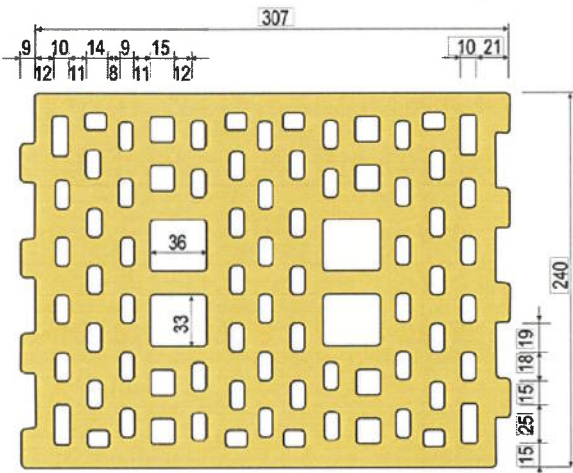

Art des Mauersteins	Foto	HAS-U 	HAS-U + HIT-SC 	Anhang
Vollziegel EN 771-1		M8 bis M16 $h_{ef} = 50 \text{ mm}$ bis 300 mm	M8 bis M16 $h_{ef} = 80 \text{ mm}$ bis 160 mm	C3/C4
Vollziegel EN 771-1		M8 bis M16 $h_{ef} = 50 \text{ mm}$ bis 300 mm	M8 bis M16 $h_{ef} = 80 \text{ mm}$ bis 160 mm	C5/C7
Vollziegel EN 771-1		M8 bis M16 $h_{ef} = 50 \text{ mm}$ bis 300 mm	M8 bis M16 $h_{ef} = 80 \text{ mm}$ bis 160 mm	C8/C10
Kalksand-vollstein EN 771-2		M8 bis M16 $h_{ef} = 50 \text{ mm}$ bis 300 mm	M8 bis M16 $h_{ef} = 80 \text{ mm}$ bis 160 mm	C11/C12
Kalksand-vollstein EN 771-2		M8 bis M16 $h_{ef} = 50 \text{ mm}$ bis 300 mm	M8 bis M16 $h_{ef} = 80 \text{ mm}$ bis 160 mm	C13/C16
Leichtbeton-vollstein EN 771-3		M8 bis M16 $h_{ef} = 50 \text{ mm}$ bis 300 mm	M8 bis M16 $h_{ef} = 80 \text{ mm}$ bis 160 mm	C17/C18
Normalbeton-vollstein EN 771-3		M8 bis M16 $h_{ef} = 50 \text{ mm}$ bis 300 mm	M8 bis M16 $h_{ef} = 80 \text{ mm}$ bis 160 mm	C19/C20
Lochziegel EN 771-1		-	M8 bis M16 $h_{ef} = 80 \text{ mm}$ bis 160 mm	C21/C22
Kalksand-lochstein EN 771-2		-	M8 bis M16 $h_{ef} = 80 \text{ mm}$ bis 160 mm	C23/C24
Leichtbeton Hohlblockstein EN 771-3		-	M8 bis M16 $h_{ef} = 80 \text{ mm}$ bis 160 mm	C25/C27
Normalbeton Lochstein EN 771-3		-	M8 bis M16 $h_{ef} = 50 \text{ mm}$ bis 160 mm	C28/C29
Lochziegel EN 771-1 Deckenstein		-	M6 $h_{ef} = 80 \text{ mm}$	C30

Hilti HIT-HY 270 mit HAS-U

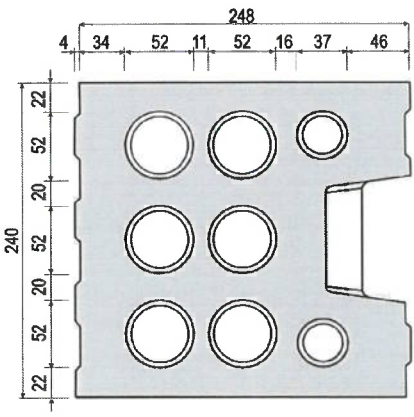
Verwendungszweck  
Befestigungselemente und entsprechende Steintypen

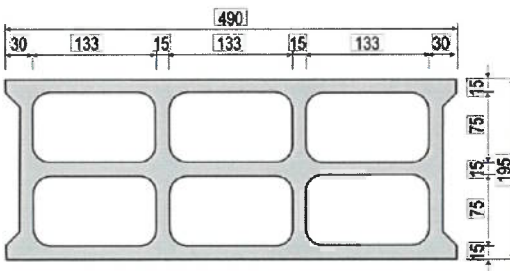
Anhang B4

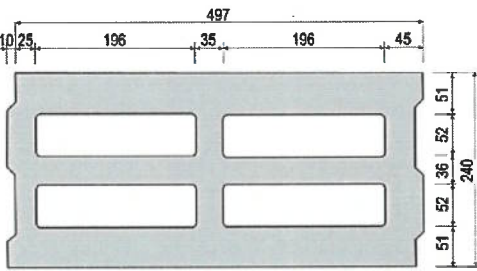
**Tabelle B4: Details der Lochsteine**

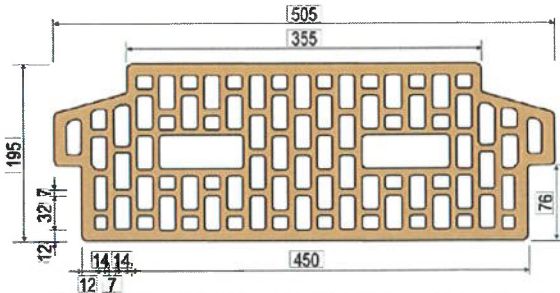

<p>Hochlochziegel EN 771-1 Rapis Ziegel Hlz 12-1,4-10DF</p>  	<p>Kalksandlochstein EN 771-2 KS Wemding KSL-R(P) 12-1,4 8DF</p>  
<p>Normalbeton Lochstein EN 771-3 Parpaing creux B40</p>  	<p>Leichtbeton Hohlblockstein EN 771-3 Knobel Betonwerk Hbl 4-0,8-500x240x238</p>  
	<p>Hochlochziegel EN 771-1 Deckenziegel Fiedler Ziegeldecke Typ 18+0 oder 18+3</p>  

Hilti HIT-HY 270 mit HAS-U

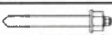

Verwendungszweck  
Details der Lochsteine

Anhang B5

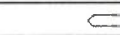

**Tabelle B5: Montagekennwerte HAS-U... mit einer Siebhülse HIT-SC für Lochstein und Vollstein (Bild A1)**

HAS-U-...		M6	M8		M10		M12		M16	
mit HIT-SC		12x85	16x50	16x85	16x50	16x85	18x50	18x85	22x50	22x85
Bohrerinnendurchmesser	$d_0$ [mm]	12	16	16	16	16	18	18	22	22
Bohrlochtiefe	$h_0$ [mm]	95	60	95	60	95	60	95	60	95
Effektive Verankerungstiefe	$h_{ef}$ [mm]	80	50	80	50	80	50	80	50	80
Maximaler Durchmesser des Durchgangslochs im Anbauteil	$d_f$ [mm]	7	9	9	12	12	14	14	18	18
Minimale Wanddicke	$h_{min}$ [mm]	115	80	115	80	115	80	115	80	115
Bürste HIT-RB	- [-]	12	16	16	16	16	18	18	22	22
Anzahl Hübe HDM	- [-]	5	4	6	4	6	4	8	6	10
Anzahl Hübe HDE 500-A	- [-]	4	3	5	3	5	3	6	5	8
Maximales Anzugsdrehmoment für alle Steine ausser "Parpaing creux"	$T_{max}$ [Nm]	0	3	3	4	4	6	6	8	8
Maximales Anzugsdrehmoment für "Parpaing creux"	$T_{max}$ [Nm]	-	2	2	2	2	3	3	6	6

**Tabelle B6: Montagekennwerte HAS-U... mit zwei Siebhülsen HIT-SC für Lochstein und Vollstein für größere Verankerungstiefen (Bild A2)**

HAS-U-...		M8		M10	
mit HIT-SC		16x50+16x85	16x85+16x85	16x50+16x85	16x85+16x85
Bohrerinnendurchmesser	$d_0$ [mm]	16		16	
Bohrlochtiefe	$h_0$ [mm]	145		180	
Effektive Verankerungstiefe	$h_{ef}$ [mm]	130		160	
Maximaler Durchmesser des Durchgangslochs im Anbauteil	$d_f$ [mm]	9		12	
Minimale Wanddicke	$h_{min}$ [mm]	195		230	
Bürste HIT-RB	- [-]	16		16	
Anzahl Hübe HDM	- [-]	4+6		6+6	
Anzahl Hübe HDE 500-A	- [-]	3+5		5+5	
Maximales Anzugsdrehmoment	$T_{max}$ [Nm]	3		4	

**Tabelle B6: Fortsetzung**

HAS-U-...		M12		M16	
mit HIT-SC		18x50+18x85	18x85+18x85	22x50+22x85	22x85+22x85
Bohrerinnendurchmesser	$d_0$ [mm]	18		22	
Bohrlochtiefe	$h_0$ [mm]	145		180	
Effektive Verankerungstiefe	$h_{ef}$ [mm]	130		160	
Maximaler Durchmesser des Durchgangslochs im Anbauteil	$d_f$ [mm]	14		18	
Minimale Wanddicke	$h_{min}$ [mm]	195		230	
Bürste HIT-RB	- [-]	18		22	
Anzahl Hübe HDM	- [-]	4+8		6+10	
Anzahl Hübe HDE 500-A	- [-]	3+6		5+8	
Maximales Anzugsdrehmoment	$T_{max}$ [Nm]	6		8	

Hilti HIT-HY 270 mit HAS-U

Verwendungszweck  
Montagekennwerte

Anhang B6

**Tabelle B7: Montagekennwerte HAS-U-... in Vollstein (Bild A3)**

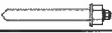
HAS-U-...			M8	M10	M12	M16
Bohrerinnendurchmesser	$d_0$	[mm]	10	12	14	18
Bohrlochtiefe = Effektive Verankerungstiefe	$h_0 =$ $h_{ef}$	[mm]	50...300	50...300	50...300	50...300
Maximaler Durchmesser des Durchgangslochs im Anbauteil	$d_f$	[mm]	9	12	14	18
Minimale Wanddicke	$h_{min}$	[mm]	$h_0+30$	$h_0+30$	$h_0+30$	$h_0+36$
Bürste HIT-RB	-	[-]	10	12	14	18
Maximales Anzugsdrehmoment	$T_{max}$	[Nm]	5	8	10	10

Hilti HIT-HY 270 mit HAS-U

Verwendungszweck  
Montagekennwerte

Anhang B7

**Tabelle B8: Montagekennwerte HAS-U-... mit zwei Siebhülsen HIT-SC für die Montage durch das Anbauteil und/oder durch eine nichttragende Schicht für Lochstein und Vollstein ( Bild A4)**

HAS-U-... mit HIT-SC			M8		M10	
			16x50+16x85	16x85+16x85	16x50+16x85	16x85+16x85
Bohrerinnendurchmesser	$d_0$	[mm]	16	16	16	16
Bohrlochtiefe	$h_0$	[mm]	145	180	145	180
Min. effektive Verankerungstiefe	$h_{ef,min}$	[mm]	80	80	80	80
Max. Dicke der nichttragenden Schicht und Anbauteildicke (Durchsteckmontage)	$h_{p,max}$	[mm]	50	80	50	80
Max. Durchmesser des Durchgangslochs im Anbauteil (Vorsteckmontage)	$d_{f1}$	[mm]	9	9	12	12
Max. Durchmesser des Durchgangslochs im Anbauteil (Durchsteckmontage)	$d_{f2}$	[mm]	17	17	17	17
Minimale Wanddicke	$h_{min}$	[mm]	$h_{ef}+65$	$h_{ef}+70$	$h_{ef}+65$	$h_{ef}+70$
Bürste HIT-RB	-	[-]	16	16	16	16
Anzahl Hübe HDM	-	[-]	4+6	6+6	4+6	6+6
Anzahl Hübe HDE 500-A	-	[-]	3+5	5+5	3+5	5+5
Maximales Anzugsdrehmoment für alle Steine außer "parpaing creux"	$T_{max}$	[Nm]	3	3	4	4
Maximales Anzugsdrehmoment für "parpaing creux"	$T_{max}$	[Nm]	2	2	2	2

**Tabelle B8 fortgesetzt**

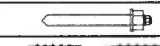
HAS-U-... mit HIT-SC			M12		M16	
			18x50+18x85	18x85+18x85	22x50+22x85	22x85+22x85
Bohrerinnendurchmesser	$d_0$	[mm]	18	18	22	22
Bohrlochtiefe	$h_0$	[mm]	145	180	145	180
Min. effektive Verankerungstiefe	$h_{ef,min}$	[mm]	80	80	80	80
Max. Dicke der nichttragenden Schicht und Anbauteildicke (Durchsteckmontage)	$h_{p,max}$	[mm]	50	80	50	80
Max. Durchmesser des Durchgangslochs im Anbauteil (Vorsteckmontage)	$d_{f1}$	[mm]	14	14	18	18
Max. Durchmesser des Durchgangslochs im Anbauteil (Durchsteckmontage)	$d_{f2}$	[mm]	19	19	23	23
Minimale Wanddicke	$h_{min}$	[mm]	$h_{ef}+65$	$h_{ef}+70$	$h_{ef}+65$	$h_{ef}+70$
Bürste HIT-RB	-	[-]	18	18	22	22
Anzahl Hübe HDM	-	[-]	4+8	8+8	6+10	10+10
Anzahl Hübe HDE 500-A	-	[-]	5+8	8+8	5+8	8+8
Maximales Anzugsdrehmoment für alle Steine außer "parpaing creux"	$T_{max}$	[Nm]	6	6	8	8
Maximales Anzugsdrehmoment für "parpaing creux"	$T_{max}$	[Nm]	3	3	6	6

Hilti HIT-HY 270 mit HAS-U

Verwendungszweck  
Montagekennwerte

Anhang B8

**Tabelle B9: Maximale Verarbeitungszeit und minimale Aushärtezeit für Vollsteine<sup>1)</sup>**

Temperatur im Verankerungsgrund T	Maximale Verarbeitungszeit $t_{work}$	Minimale Aushärtezeit $t_{cure}$
5 °C bis 9 °C	10 min	2,5 h
10 °C bis 19 °C	7 min	1,5 h
20 °C bis 29 °C	4 min	30 min
30 °C bis 40 °C	1 min	20 min

<sup>1)</sup> Die Aushärtezeiten gelten nur für trockenen Verankerungsgrund.  
In feuchtem Verankerungsgrund müssen die Aushärtezeiten verdoppelt werden.

**Tabelle B10: Maximale Verarbeitungszeit und minimale Aushärtezeit<sup>1)</sup> für Lochsteine**

Temperatur im Verankerungsgrund T	Maximale Verarbeitungszeit $t_{work}$	Minimale Aushärtezeit $t_{cure}$
0 °C bis 4 °C	10 min	4 h
5 °C bis 9 °C	10 min	2,5 h
10 °C bis 19 °C	7 min	1,5 h
20 °C bis 29 °C	4 min	30 min
30 °C bis 40 °C	1 min	20 min

<sup>1)</sup> Die Aushärtezeiten gelten nur für trockenen Verankerungsgrund.  
In feuchtem Verankerungsgrund müssen die Aushärtezeiten verdoppelt werden.

**Tabelle B11: Reinigungsalternativen**

**Handreinigung (MC):**

zum Ausblasen von Bohrlöchern bis zu einem Durchmesser von  $d_0 \leq 18$  mm und einer Bohrlochtiefe von  $h_0 = 100$  mm wird die Hilti-Handausblaspumpe empfohlen.



**Druckluftreinigung (CAC):**

zum Ausblasen von Bohrlöchern bis zu einer Bohrlochtiefe von  $h_0 = 300$  mm wird eine Ausblasdüse mit einem Durchmesser von mindestens 3,5 mm empfohlen.



**Stahlbürste HIT-RB:**

gemäß Tabelle B5 bis B8 in Abhängigkeit vom Bohrlochdurchmesser für MC und CAC



Hilti HIT-HY 270 mit HAS-U

Verwendungszweck  
Montagekennwerte  
Reinigungswerkzeuge

Anhang B9

## Montageanweisung

### Bohrlocherstellung

Wenn beim Bohren über die gesamte Bohrlochtiefe (z.B. in nicht verfüllten Stoßfugen) kein nennenswerter Bohrwiderstand spürbar ist, so ist diese Setzposition zu verwerfen.

### Bohrverfahren

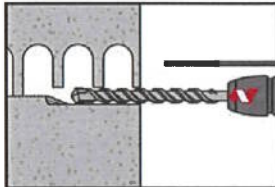

#### Im Hohlstein und Vollstein (Nutzungskategorie c): Drehbohren

Bohrloch mit Bohrhammer im Drehmodus, unter Verwendung des passenden Bohrerdurchmessers, auf die richtige Bohrtiefe erstellen.

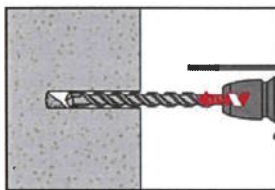

#### Im Vollstein (Nutzungskategorie b): Hammerbohren

Bohrloch mit Bohrhammer drehschlagend, unter Verwendung des passenden Bohrerdurchmessers, auf die richtige Bohrtiefe erstellen.

### Bohrlochreinigung

Unmittelbar vor dem Setzen des Dübels muss das Bohrloch frei von Bohrmehl und Verunreinigungen sein. Schlechte Bohrlochreinigung = geringe Traglasten.

### Handreinigung (MC): Für Lochsteine und Vollsteine

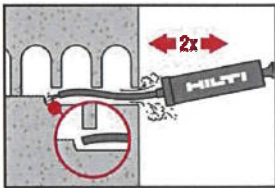

Für Bohrlochdurchmesser  $d_0 \leq 18$  mm und Bohrlochtiefen bis  $h_0 = 100$  mm kann die Hilti Handausblaspumpe verwendet werden.

Bohrloch mindestens 4-mal mit der Hilti Ausblaspumpe vom Bohrlochgrund ausblasen, bis die rückströmende Luft staubfrei ist.

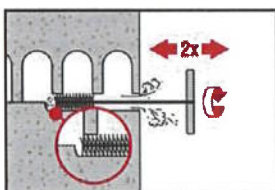

2-mal mit Stahlbürste in passender Größe (siehe Tabelle B5 bis B8) bürsten. Stahlbürste Hilti HIT-RB mit einer Drehbewegung in das Bohrloch bis zum Bohrlochgrund einführen und wieder herausziehen (falls notwendig mit Verlängerung).

Die Bürste muss beim Einführen einen Widerstand erzeugen (Bürste  $\varnothing \geq$  Bohrloch  $\varnothing$ ) – falls nicht, ist die Bürste zu klein und muss durch eine geeignete Bürste ersetzt werden.

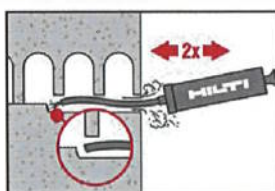

Bohrloch erneut mit der Hilti Handausblaspumpe vom Bohrlochgrund mindestens 4-mal ausblasen, bis die rückströmende Luft staubfrei ist.

Hilti HIT-HY 270 mit HAS-U

Verwendungszweck  
Montageanweisung

Anhang B10

**Handreinigung (CAC): Für Lochsteine und Vollsteine**

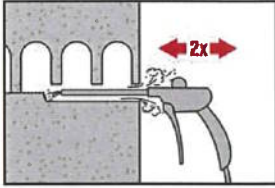

Bohrloch 2-mal vom Bohrlochgrund über die gesamte Länge mit ölfreier Druckluft (min. 6 bar bei 6 m<sup>3</sup>/h; Bohrlochtiefe bis h<sub>0</sub> = 300 mm) ausblasen, bis die rückströmende Luft staubfrei ist. Falls notwendig Verlängerung verwenden.

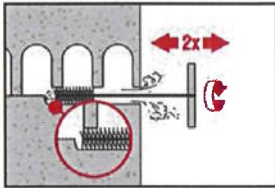

2-mal mit Stahlbürste in passender Größe (siehe Tabelle B5 bis B8) bürsten. Stahlbürste Hilti HIT-RB mit einer Drehbewegung in das Bohrloch bis zum Bohrlochgrund einführen und wieder herausziehen (falls notwendig mit Verlängerung). Die Bürste muss beim Einführen einen Widerstand erzeugen (Bürste  $\varnothing \geq$  Bohrloch  $\varnothing$ ) – falls nicht, ist die Bürste zu klein und muss durch eine geeignete Bürste ersetzt werden.

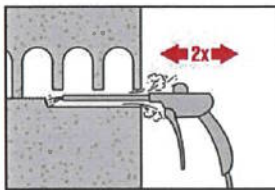

Bohrloch erneut mit der Hilti Handpumpe oder Druckluft 2-mal ausblasen, bis die rückströmende Luft staubfrei ist.

**Injektionsvorbereitung bei Mauerwerk mit Lochanteil und Hohlräumen: Montage mit Siebhülse HIT-SC**

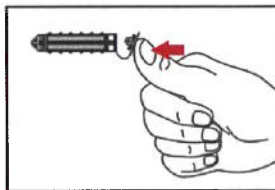

**Einzelsiebhülse HIT-SC**  
Kappe aufstecken

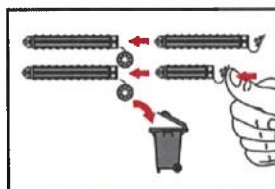

**Zwei Siebhülsen HIT-SC**  
Siebhülsen zusammenstecken und überflüssige Kappe entsorgen.  
Beachten, dass im Falle von unterschiedlichen Siebhülsenlängen die kurze Siebhülse in die lange Siebhülse gesteckt wird.

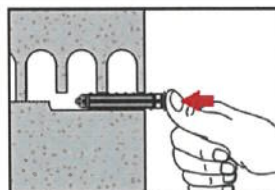

Siebhülse manuell einschieben.  
Bei der Verwendung von zwei Siebhülsen muss die Längere zuerst eingeschoben werden.

Hilti HIT-HY 270 mit HAS-U

Verwendungszweck  
Montageanweisung

Anhang B11



### Für alle Anwendungen

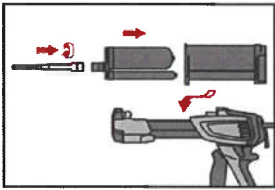

Statikmischer HIT-RE-M fest auf Foliengebilde aufschrauben. Den Mischer unter keinen Umständen verändern.  
Bedienungsanleitung des Auspressgerätes und des Mörtels befolgen.  
Prüfen der Kassette und des Foliengebundes auf einwandfreie Funktion.  
Kein beschädigtes Gebinde / Kassette verwenden.  
Foliengebilde in die Kassette einführen und Kassette in Auspressgerät einsetzen.

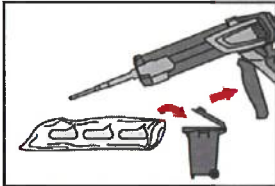

Das Öffnen der Foliengebilde erfolgt automatisch bei Auspressbeginn. Der am Anfang aus dem Mischer austretende Mörtelvorlauf darf nicht für Befestigungen verwendet werden. Die Menge des Mörtelvorlaufes ist abhängig von der Gebindegröße:

2 Hübe bei 330 ml Foliengebilde,  
3 Hübe bei 500 ml Foliengebilde.

### Injektion des Mörtels ohne Luftblasen zu bilden

#### Montage mit Siebhülse HIT-SC

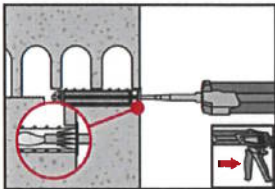

##### Einzelsiebhülse HIT-SC

Den Mischer ca. 1 cm in die Kappe einschieben. Die gemäß Tabelle B5 bis B8 angegebene Mörtelmenge injizieren. Mörtel muss aus der Kappe austreten.

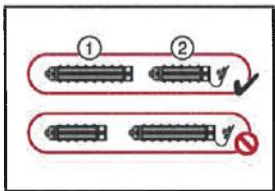

##### Zwei Siebhülsen HIT-SC

Mischerverlängerung bei der Montage von zwei Siebhülsen verwenden.  
Den Mischer ca. 1 cm durch die Spitze der Siebhülse "2" einschieben. Die gemäß Tabelle B5 bis B8 angegebene Mörtelmenge in die Siebhülse "1" injizieren.  
Mischer zurückziehen, bis er 1 cm in der Kappe der Siebhülse "2" steckt und Mörtel, wie vorher beschrieben, in die Siebhülse "2" injizieren.

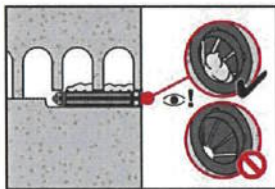

Kontrolle der injizierten Mörtelmenge. Der Mörtel muss aus der Kappe ausgetreten sein.

Nach der Mörtelinjektion die Entriegelungstaste am Auspressgerät betätigen, um Mörtelnachlauf zu vermeiden.

Hilti HIT-HY 270 mit HAS-U

Verwendungszweck  
Montageanweisung

Anhang B12

### Vollsteine: Montage ohne Siebhülse

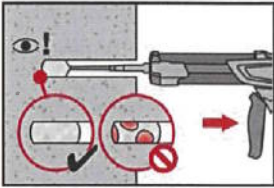

Injizieren des Mörtels vom Bohrlochgrund und während jedes Hubes den Mischer zurückziehen.  
Das Bohrloch zu ca. 2/3 verfüllen. Nach dem Einsetzen des Befestigungselementes muss der Ringspalt zwischen Dübel und Untergrund, über die gesamte Verankerungstiefe, vollständig mit Mörtel ausgefüllt sein.

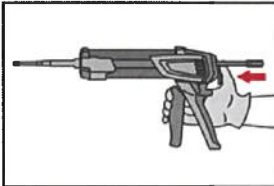

Nach der Mörtelinjektion die Entriegelungstaste am Auspressgerät betätigen, um Mörtelnachlauf zu vermeiden.

### Setzen des Befestigungselementes:

Vor der Montage sicherstellen, dass das Element trocken und frei von Öl und anderen Verunreinigungen ist.

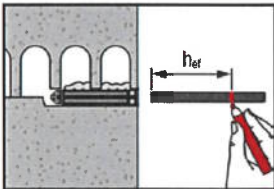

#### HAS-U-... in Lochstein und Vollstein: Vorsteckmontage (Bild A1 bis Bild A4)

Befestigungselement markieren und bis zur gewünschten Verankerungstiefe  $h_{ef}$  gemäß Tabelle B5 bis B7 einführen.

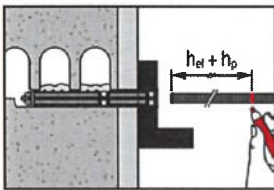

#### HAS-U-... in Lochstein und Vollstein: Montage durch das Anbauteil (Bild A4a)

#### oder durch die nichttragende Schicht und das Anbauteil (Bild A4b)

Befestigungselement markieren und bis zur gewünschten Verankerungstiefe  $h_{ef} + h_p$  gemäß Tabelle B8 einführen.

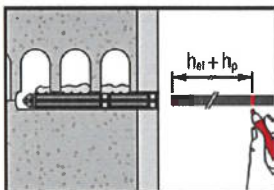

#### HAS-U-... in Lochstein und Vollstein:

#### Montage durch die nichttragende Schicht (Bild A4c)

Befestigungselement markieren und bis zur gewünschten Verankerungstiefe  $h_{ef} + h_p$  gemäß Tabelle B8 einführen.

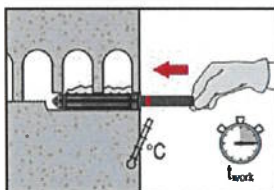

Befestigungselement noch bevor die Verarbeitungszeit  $t_{work}$  abgelaufen ist setzen. Verarbeitungszeit  $t_{work}$  siehe Tabelle B9 und Tabelle B10.

### Belasten des Dübels

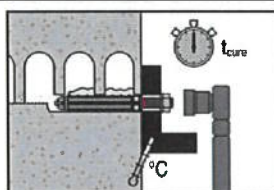

Nach Ablauf der Aushärtezeit  $t_{cure}$  (siehe Tabelle B9 und Tabelle B10) kann der Dübel belastet werden.

Das aufzubringende Drehmoment darf die angegebenen Werte  $T_{max}$  gemäß Tabelle B5 bis B8 nicht überschreiten.

Hilti HIT-HY 270 mit HAS-U

Verwendungszweck  
Montageanweisung

Anhang B13

**Tabelle C1:  $\beta$ -Faktor für Baustellenversuche unter Zugbelastung**

Nutzungskategorien		w/w und w/d		d/d	
Temperatur Bereich		Ta*	Tb*	Ta*	Tb*
Base material	Cleaning				
Vollziegel EN 771-1	CAC	0,96	0,96	0,96	0,96
	MC	0,84	0,84	0,84	0,84
Kalksandvollstein EN 771-2	CAC/MC	-	-	0,96	0,80
Leichtbetonvollstein EN 771-3	CAC	0,82	0,68	0,96	0,80
	MC	0,81	0,67	0,90	0,75
Normalbetonvollstein EN 771-3	CAC/MC	0,96	0,80	0,96	0,80
Lochziegel EN 771-1	CAC	0,96	0,96	0,96	0,96
	MC	0,84	0,84	0,84	0,84
Kalksandlochstein EN 771-2	CAC/MC	-	-	0,96	0,80
Leichtbeton Hohlblockstein EN 771-3	CAC	0,69	0,57	0,81	0,67
	MC	0,68	0,56	0,76	0,63
Normalbeton Lochstein EN 771-3	CAC/MC	0,96	0,80	0,96	0,80

\* Temperaturbereich Ta / Tb siehe Anlage B1

**Tabelle C2: Charakteristische Werte der Stahltragfähigkeit für HAS-U unter Zuglast und Querlast in Mauerwerk**

Stahlversagen Zuglast		M6	M8	M10	M12	M16
Charakteristische Stahltragfähigkeit	$N_{Rk,s}$ [kN]	$A_s \cdot f_{uk}$				
Stahlversagen Querlast ohne Hebelarm						
Charakteristische Stahltragfähigkeit	$V_{Rk,s}$ [kN]	$0,5 \cdot A_s \cdot f_{uk}$				
Stahlversagen Querlast mit Hebelarm						
Charakteristisches Biegemoment	$M_{Rk,s}$ [Nm]	$1,2 \cdot W_{el} \cdot f_{uk}$				

Hilti HIT-HY 270 mit HAS-U

**Leistung**

$\beta$ -Faktor für Baustellenversuche unter Zugbelastung  
Charakteristische Werte unter Zuglast und Querlast - Stahlversagen

**Anhang C1**

**Achsabstand in Abhängigkeit vom Randabstand für alle Dübelkombinationen:**

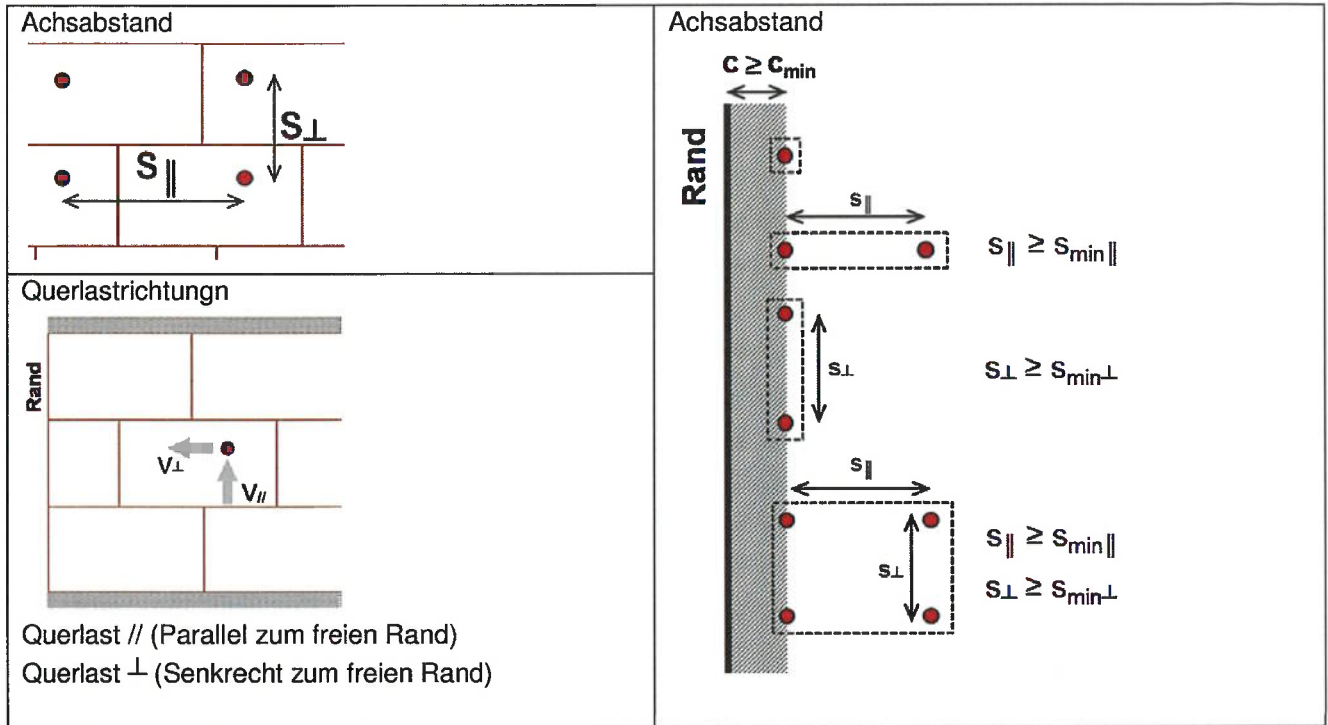

Die charakteristischen Widerstände einer Dübelgruppe werden unter Verwendung von Gruppenfaktoren  $\alpha_g$  gemäß Anhang C3 bis C30, berechnet

Gruppe mit zwei Dübeln:  $N_{Rk}^g = \alpha_{g,N} \cdot N_{Rk}$  und  $V_{Rk}^g = \alpha_{g,V} \cdot V_{Rk}$  (mit den relevanten  $\alpha_g$ )

Gruppe mit vier Dübeln:  $N_{Rk}^g = \alpha_{g,N \parallel} \cdot \alpha_{g,N \perp} \cdot N_{Rk}$  und  $V_{Rk}^g = \alpha_{g,V \parallel} \cdot \alpha_{g,V \perp} \cdot V_{Rk}$

**Hilti HIT-HY 270 mit HAS-U**

**Leistung**  
Dübel Achsabstand

**Anhang C2**

**Art des Mauersteins: Vollziegel Mz, 1DF**

**Tabelle C3: Beschreibung des Mauersteins**

Steintyp		Solid Mz, 1DF	
Rohdichte	$\rho$ [kg/dm <sup>3</sup> ]	$\geq 2,0$	
Druckfestigkeit	$f_b$ [N/mm <sup>2</sup> ]	$\geq 12 / 20 / 40$	
Norm		EN 771 - 1	
Hersteller			
Steinabmessungen	[mm]	$\geq 240 \times 115 \times 52$	
Minimale Wanddicke	$h_{min}$ [mm]	$\geq 115$	





**Charakteristische Werte der Tragfähigkeit für alle Dübelkombinationen (siehe Tabelle B3)**

**Tabelle C4: Zugtragfähigkeit bei Randabstand  $c \geq 115$  mm**

Nutzungskategorie			w/w = w/d		d/d	
Gebrauchstemperaturbereich			Ta	Tb	Ta	Tb
Dübeltyp und -größe	$h_{ef}$ [mm]	$f_b$ [N/mm <sup>2</sup> ]	$N_{Rk,p} = N_{Rk,b}$ [kN]			
Alle Dübel	$\geq 50$	12	1,5 (2,0*)			
		20	2,0 (2,5*)			
		40	3,5 (4,0*)			
	$\geq 80$	12	2,5 (3,0*)			
		20	3,5 (4,0*)			
		40	5,5 (6,5*)			
	$\geq 100$	12	3,5 (4,0*)			
		20	4,5 (5,0*)			
		40	7,0 (8,0*)			

\* nur CAC Reinigung

Zugehörige Achs- und Randabstände und Gruppenfaktoren  $\alpha_g$

Anordnung	$c \geq$ [mm]	$s_{\perp} \geq$ [mm]	$\alpha_g$ [-]	Anordnung	$c \geq$ [mm]	$s_{  } \geq$ [mm]	$\alpha_g$ [-]
	115	-	-	-	-	-	-
	115	55	1,0		115	75	1,35
	115	115	2,0		115	3 $h_{ef}$	2,0

**Hilti HIT-HY 270 mit HAS-U**

**Leistung Vollziegel Mz, 1DF**  
Charakteristische Werte der Tragfähigkeit unter Zuglast und Gruppenfaktor

**Anhang C3**

**Tabelle C5: Quertragfähigkeit bei Randabstand  $c \geq 115$  mm (für  $V_{II}$ ) und  $c \geq 1,5 h_{ef}$  (für  $V_{\perp}$ )**

Dübeltyp und -größe	$h_{ef}$ [mm]	$f_b$ [N/mm <sup>2</sup> ]	$V_{Rk,b} = V_{Rk,c II}$ [kN]	$V_{Rk,c \perp}$
HAS-U M8; M10	$\geq 50$	12	2,5	Bemessung gemäß TR 054 Formel 10
		20	3,0	
		40	4,0	
HAS-U M12; M16	$\geq 50$	12	3,5	
		20	4,5	
		40	5,5	
HAS-U M8; M10	$\geq 80$	12	5,0	
		20	6,0	
		40	7,5	
HAS-U M12; M16	$\geq 80$	12	6,5	
		20	8,5	
		40	10,5	

Zugehörige Achs- und Randabstände und Gruppenfaktoren  $\alpha_g$

Anordnung	$c \geq$ [mm]	$s_{\perp} \geq$ [mm]	$\alpha_g$ [-]	Anordnung	$c \geq$ [mm]	$s_{\perp} \geq$ [mm]	$\alpha_g$ [-]
	115	-	-		$1,5 h_{ef}$	-	-
	115	55	1,0		$1,5 h_{ef}$	55	1,0
	115	115	2,0		$1,5 h_{ef}$	$3 h_{ef}$	2,0
Anordnung	$c \geq$ [mm]	$s_{II}$ [mm]	$\alpha_g$ [-]	Anordnung	$c \geq$ [mm]	$s_{II}$ [mm]	$\alpha_g$ [-]
					$1,5 h_{ef}$	115	1,0
	115	75	2,0		$1,5 h_{ef}$	$3 h_{ef}$	2,0

**Tabelle C6: Verschiebungen**

$h_{ef}$	<b>N</b>	$\delta_{N0}$	$\delta_{N\infty}$	<b>V</b>	$\delta_{V0}$	$\delta_{V\infty}$
[mm]	[kN]	[mm]	[mm]	[kN]	[mm]	[mm]
50	1,2	0,1	0,2	1,4	0,5	0,75
80	2,1	0,1	0,2	2,1	1,1	1,65
100	3,9	0,2	0,4	3,0	1,3	1,95

Hilti HIT-HY 270 mit HAS-U

Leistung Vollziegel Mz, 1DF

Charakteristische Werte der Tragfähigkeit unter Querlast und Gruppenfaktor  
Verschiebungen

Anhang C4

**Art des Mauersteins: Vollziegel Mz, NF**

**Tabelle C7: Beschreibung des Mauersteins**

Steintyp		Mz, NF	
Rohdichte	$\rho$ [kg/dm <sup>3</sup> ]	2,0	
Druckfestigkeit	$f_b$ [N/mm <sup>2</sup> ]	≥ 10 / 20	
Norm		EN 771 - 1	
Hersteller			
Steinabmessungen	[mm]	≥ 240 x 115 x 71	
Minimale Wanddicke	$h_{min}$ [mm]	≥ 115	





**Charakteristische Werte der Tragfähigkeit für alle Dübelkombinationen (siehe Tabelle B3)**

**Tabelle C8: Zugtragfähigkeit bei Randabstand  $c \geq 50$  mm**

Nutzungskategorie			w/w = w/d		d/d	
Gebrauchstemperaturbereich			Ta	Tb	Ta	Tb
Dübeltyp und -größe	$h_{ef}$ [mm]	$f_b$ [N/mm <sup>2</sup> ]	$N_{Rk,p} = N_{Rk,b}$ [kN]			
Alle Dübel	≥ 50	10	1,5 (1,5*)			
		20	2,0 (2,0*)			
	≥ 80	10	2,5 (3,0*)			
		20	3,5 (4,0*)			

\* nur CAC Reinigung

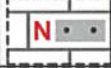
Zugehörige Achs- und Randabstände und Gruppenfaktoren  $\alpha_g$

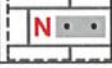
Anordnung	$c \geq$ [mm]	$s_{\perp} \geq$ [mm]	$\alpha_g$ [-]	Anordnung	$c \geq$ [mm]	$s_{\parallel} \geq$ [mm]	$\alpha_g$ [-]
	50	-	-	-	-	-	-
	50	75	1,0		115	50	1,0
-	-	-	-		50	115	1,15
	50	150	2,0		50	3 $h_{ef}$	2,0

**Hilti HIT-HY 270 mit HAS-U**

**Leistung Vollziegel Mz, NF**  
Charakteristische Werte der Tragfähigkeit unter Zuglast und Gruppenfaktor

**Anhang C5**

**Tabelle C9: Zugtragfähigkeit bei Randabstand  $c \geq 150$  mm**

Nutzungskategorie			w/w = w/d		d/d	
Gebrauchstemperaturbereich			Ta	Tb	Ta	Tb
Dübeltyp und -größe	$h_{ef}$ [mm]	$f_b$ [N/mm <sup>2</sup> ]	$N_{Rk,p} = N_{Rk,b}$ [kN]			
Alle Dübel	$\geq 100$	10	4,0 (4,5*)			
		20	5,5 (6,0*)			

\* nur CAC Reinigung

Zugehörige Achs- und Randabstände und Gruppenfaktoren  $\alpha_g$

Anordnung	$c \geq$ [mm]	$s_{\perp} \geq$ [mm]	$\alpha_g$ [-]	Anordnung	$c \geq$ [mm]	$s_{\parallel} \geq$ [mm]	
	150	-	-	-	-	-	-
	150	75	1,40		150	50	0,75
-	-	-	-		150	115	1,35
	150	150	2,0		150	$3 h_{ef}$	2,0

**Tabelle C10: Quertragfähigkeit bei Randabstand  $c \geq 1,5 h_{ef}$**

Dübeltyp und -größe	$h_{ef}$ [mm]	$f_b$ [N/mm <sup>2</sup> ]	$V_{Rk,b} = V_{Rk,c \parallel}$ [kN]	$V_{Rk,c \perp}$
Alle Dübel	$\geq 50$	10	3,0	Bemessung gemäß TR 054 Formel 10
		20	4,5	
HAS-U M8; M10	$\geq 80$	10	5,0	
		20	7,0	
HAS-U M8; M10	$\geq 100$	10	8,0	
		20	11,0	
HAS-U M12; M16	$\geq 80$	10	9,0	
		20	12,0	

Zugehörige Achs- und Randabstände und Gruppenfaktoren  $\alpha_g$

Anordnung	$c \geq$ [mm]	$s_{\perp} \geq$ [mm]	$\alpha_g$ [-]	Anordnung	$c \geq$ [mm]	$s_{\perp} \geq$ [mm]	$\alpha_g$ [-]
	$1,5 h_{ef}$	-	-		$1,5 h_{ef}$	-	-
	$1,5 h_{ef}$	75	1,55		$1,5 h_{ef}$	75	1,0
	$1,5 h_{ef}$	150	2,0		$1,5 h_{ef}$	$3 h_{ef}$	2,0
Anordnung	$c \geq$ [mm]	$s_{\parallel}$ [mm]	$\alpha_g$ [-]	Anordnung	$c \geq$ [mm]	$s_{\parallel}$ [mm]	$\alpha_g$ [-]
	$1,5 h_{ef}$	50	1,2		$1,5 h_{ef}$	50	1,60
	$1,5 h_{ef}$	75	1,5		$1,5 h_{ef}$	$3 h_{ef}$	2,0
	$1,5 h_{ef}$	115	2,0	-	-	-	-

Hilti HIT-HY 270 mit HAS-U

Leistung Vollziegel Mz, NF  
Charakteristische Werte der Tragfähigkeit unter Zug- und Querlast und Gruppenfaktor

Anhang C6



**Tabelle C11: Quertragfähigkeit bei Randabstand  $c \geq 50$  mm**

Dübeltyp und -größe	$h_{ef}$ [mm]	$f_b$ [N/mm <sup>2</sup> ]	$V_{Rk,b} = V_{Rk,cII}$ [kN]
Alle Dübel	$\geq 50$	10	3,0
		20	4,5
	$\geq 80$	10	4,0
		20	5,5

Zugehörige Achs- und Randabstände und Gruppenfaktoren  $\alpha_g$

Anordnung	$c \geq$ [mm]	$s_{\perp} \geq$ [mm]	$\alpha_g$ [-]
	50	-	-
	50	75	1,55
	50	150	2,0
Anordnung	$c \geq$ [mm]	$s_{  }$ [mm]	$\alpha_g$ [-]
	50	50	1,2
	50	115	2,0

**Tabelle C12: Verschiebungen**

$h_{ef}$	<b>N</b>	$\delta_{N0}$	$\delta_{N\infty}$	<b>V</b>	$\delta_{V0}$	$\delta_{V\infty}$
[mm]	[kN]	[mm]	[mm]	[kN]	[mm]	[mm]
50	0,8	0,1	0,2	1,6	0,8	1,2
80	1,5	0,1	0,2	2,1	0,8	1,2
100	2,3	0,1	0,2	2,1	0,8	1,2

Hilti HIT-HY 270 mit HAS-U

Leistung Vollziegel Mz, NF

Charakteristische Werte der Tragfähigkeit unter Querlast und Gruppenfaktor  
Verschiebungen

Anhang C7

**Art des Mauersteins: Vollziegel Mz, 2DF**

**Tabelle C13: Beschreibung des Mauersteins**

Steintyp		Mz, 2DF	
Rohdichte	$\rho$ [kg/dm <sup>3</sup> ]	≥ 2,0	
Druckfestigkeit	$f_b$ [N/mm <sup>2</sup> ]	≥ 12 / 20	
Norm		EN 771 - 1	
Hersteller			
Steinabmessungen	[mm]	≥ 240 x 115 x 113	
Minimale Wanddicke	$h_{min}$ [mm]	≥ 115	







**Charakteristische Werte der Tragfähigkeit für alle Dübelkombinationen (siehe Tabelle B3)**

**Tabelle C14: Zugtragfähigkeit bei Randabstand  $c \geq 115$  mm**

Nutzungskategorie			w/w = w/d		d/d	
Gebrauchstemperaturbereich			Ta	Tb	Ta	Tb
Dübeltyp und -größe	$h_{ef}$ [mm]	$f_b$ [N/mm <sup>2</sup> ]	$N_{Rk,p} = N_{Rk,b}$ [kN]			
Alle Dübel	≥ 50	12	2,5 (3,0*)			
		20	2,5 (3,0*)			
	≥ 80	12	3,5 (4,0*)			
		20	4,5 (5,5*)			
	≥ 100	12	6,0 (7,0*)			
		20	7,0 (8,0*)			

\* nur CAC Reinigung

Zugehörige Achs- und Randabstände und Gruppenfaktoren  $\alpha_g$

Anordnung	$c \geq$ [mm]	$s_{\perp} \geq$ [mm]	$\alpha_g$ [-]	Anordnung	$c \geq$ [mm]	$s_{\parallel} \geq$ [mm]	$\alpha_g$ [-]
	115	-	-	-	-	-	-
	115	75	1,0		115	75	1,50
	115	115	1,60	-	-	-	-
	115	3 $h_{ef}$	2,0		115	3 $h_{ef}$	2,0

**Hilti HIT-HY 270 mit HAS-U**

**Leistung Vollziegel Mz, 2DF**

Charakteristische Werte der Tragfähigkeit unter Zuglast und Gruppenfaktor

**Anhang C8**

**Tabelle C15: Zugtragfähigkeit bei Randabstand  $c \geq 50$  mm**

Nutzungskategorie			w/w = w/d		d/d	
Gebrauchstemperaturbereich			Ta	Tb	Ta	Tb
Dübeltyp und -größe	$h_{ef}$ [mm]	$f_b$ [N/mm <sup>2</sup> ]	$N_{Rk,p} = N_{Rk,b}$ [kN]			
Alle Dübel	$\geq 50$	12	1,5 (1,5*)			
		20	2,0 (2,0*)			
	$\geq 80$	12	3,0 (3,5*)			
		20	3,5 (4,0*)			

\* nur CAC Reinigung

Zugehörige Achs- und Randabstände und Gruppenfaktoren  $\alpha_g$

Anordnung	$c \geq$ [mm]	$s_{\perp} \geq$ [mm]	$\alpha_g$ [-]	Anordnung	$c \geq$ [mm]	$s_{\parallel} \geq$ [mm]	$\alpha_g$ [-]
	50	-	-	-	-	-	-
	50	75	1,10		115	50	1,0
	50	115	1,45		50	115	1,15
	50	3 $h_{ef}$	2,0		50	3 $h_{ef}$	2,0

**Tabelle C16: Quertragfähigkeit bei Randabstand  $c \geq 1,5 h_{ef}$**

Dübeltyp und -größe	$h_{ef}$ [mm]	$f_b$ [N/mm <sup>2</sup> ]	$V_{Rk,b} = V_{Rk,c \parallel}$ [kN]	$V_{Rk,c \perp}$
Alle Dübel	$\geq 50$	12	5,5	Bemessung gemäß TR 054 Formel 10 (bei $h_{ef} > 80$ mm berechne mit $h_{ef} = 80$ mm)
		20	7,0	
HAS-U M8; M10	$\geq 80$	12	8,0	
		20	10,0	
HAS-U M12	$\geq 80$	12	10,5	
		20	12,0	
HAS-U M16	$\geq 80$	12	12,0	
		20	12,0	

Zugehörige Achs- und Randabstände und Gruppenfaktoren  $\alpha_g$

Anordnung	$c \geq$ [mm]	$s_{\perp} \geq$ [mm]	$\alpha_g$ [-]	Anordnung	$c \geq$ [mm]	$s_{\parallel} \geq$ [mm]	$\alpha_g$ [-]
	1,5 $h_{ef}$	-	-		1,5 $h_{ef}$	-	-
	1,5 $h_{ef}$	75	0,85		1,5 $h_{ef}$	115	0,75
	1,5 $h_{ef}$	3 $h_{ef}$	2,0		1,5 $h_{ef}$	3 $h_{ef}$	2,0
Anordnung	$c \geq$ [mm]	$s_{\parallel}$ [mm]	$\alpha_g$ [-]	Anordnung	$c \geq$ [mm]	$s_{\parallel}$ [mm]	$\alpha_g$ [-]
	1,5 $h_{ef}$	115	1,60		1,5 $h_{ef}$	115	0,8
	1,5 $h_{ef}$	3 $h_{ef}$	2,0		1,5 $h_{ef}$	3 $h_{ef}$	2,0

Hilti HIT-HY 270 mit HAS-U

Leistung Vollziegel Mz, 2DF

Charakteristische Werte der Tragfähigkeit unter Querlast und Gruppenfaktor

Anhang C9

**Tabelle C17: Quertragfähigkeit bei Randabstand  $c \geq 50$  mm**

Dübeltyp und -größe	$h_{ef}$ [mm]	$f_b$ [N/mm <sup>2</sup> ]	$V_{Rk,b} = V_{Rk,cII}$ [kN]
Alle Dübel	$\geq 50$	12	3,0
		20	4,0
Alle Dübel	$\geq 80$	12	4,5
		20	5,5

Zugehörige Achs- und Randabstände und Gruppenfaktoren  $\alpha_g$

Anordnung	$c \geq$ [mm]	$s_{\perp} \geq$ [mm]	$\alpha_g$ [-]
	50	-	-
	50	75	0,70
	50	115	1,5
	50	$3 h_{ef}$	2,0
Anordnung	$c \geq$ [mm]	$s_{  }$ [mm]	$\alpha_g$ [-]
	50	115	2,0

**Tabelle C18: Verschiebungen**

$h_{ef}$	<b>N</b>	$\delta_{N0}$	$\delta_{N\infty}$	<b>V</b>	$\delta_{V0}$	$\delta_{V\infty}$
[mm]	[kN]	[mm]	[mm]	[kN]	[mm]	[mm]
50	0,9	0,1	0,2	1,9	0,6	0,9
80	1,3	0,2	0,4	2,8	1,0	1,5
100	1,7	0,3	0,6	2,8	1,0	1,5

Hilti HIT-HY 270 mit HAS-U

Leistung Vollziegel Mz, 2DF

Charakteristische Werte der Tragfähigkeit unter Querlast und Gruppenfaktor  
Verschiebungen

Anhang C10

**Art des Mauersteins: Kalksandvollstein KS, 2DF**

**Tabelle C19: Beschreibung des Mauersteins**







Steintyp		KS, 2DF	
Rohdichte	$\rho$ [kg/dm <sup>3</sup> ]	≥ 2,0	
Druckfestigkeit	$f_b$ [N/mm <sup>2</sup> ]	≥ 12 / 28	
Norm		EN 771 - 2	
Hersteller			
Steinabmessungen	[mm]	≥ 240 x 115 x 113	
Minimale Wanddicke	$h_{min}$ [mm]	≥ 115	

**Charakteristische Werte der Tragfähigkeit für alle Dübelkombinationen (siehe Tabelle B3)**

**Tabelle C20: Zugtragfähigkeit bei Randabstand  $c \geq 115$  mm**

Nutzungskategorie			w/w = w/d		d/d	
Gebrauchstemperaturbereich			Ta	Tb	Ta	Tb
Dübeltyp und -größe	$h_{ef}$ [mm]	$f_b$ [N/mm <sup>2</sup> ]	$N_{Rk,p} = N_{Rk,b}$ [kN]			
Alle Dübel	≥ 50	12	-	-	6,0	5,0
		28	-	-	9,0	7,5

Zugehörige Achs- und Randabstände und Gruppenfaktoren  $\alpha_g$



Anordnung	$c \geq$ [mm]	$s_{\perp} \geq$ [mm]	$\alpha_g$ [-]	Anordnung	$c \geq$ [mm]	$s_{  } \geq$ [mm]	$\alpha_g$ [-]
	115	-	-	-	-	-	-
	115	50	1,0		115	50	1,0
	115	115	1,45	-	-	-	-
	115	150	2,0		115	115 (H)* 240 (S)*	2,0

\* (H) = Binder, (S) = Läufer

**Tabelle C21: Zugtragfähigkeit bei Randabstand  $c \geq 50$  mm**

Nutzungskategorie			w/w = w/d		d/d	
Gebrauchstemperaturbereich			Ta	Tb	Ta	Tb
Dübeltyp und -größe	$h_{ef}$ [mm]	$f_b$ [N/mm <sup>2</sup> ]	$N_{Rk,p} = N_{Rk,b}$ [kN]			
Alle Dübel	≥ 50	12	-	-	4,0	3,5
		28	-	-	6,5	5,5

Zugehörige Achs- und Randabstände und Gruppenfaktoren  $\alpha_g$

Anordnung	$c \geq$ [mm]	$s_{\perp} \geq$ [mm]	$\alpha_g$ [-]	Anordnung	$c \geq$ [mm]	$s_{  } \geq$ [mm]	$\alpha_g$ [-]
	50	-	-	-	-	-	-
	50	115	2,0		50	115 (H)* 240 (S)*	2,0

\* (H) = Binder, (S) = Läufer

**Hilti HIT-HY 270 mit HAS-U**

**Leistung Kalksandvollstein KS, 2DF**  
Charakteristische Werte der Tragfähigkeit unter Zuglast und Gruppenfaktor

**Anhang C11**

**Tabelle C22: Quertragfähigkeit bei Randabstand  $c \geq 115$  mm**

Dübeltyp und -größe	$h_{ef}$ [mm]	$f_b$ [N/mm <sup>2</sup> ]	$V_{Rk,b} = V_{Rk,c \parallel}$ [kN]	$V_{Rk,c \perp}$
Alle Dübel	$\geq 50$	12	6,0	Bemessung gemäß TR 054 Formel 10
		28	9,0	

Zugehörige Achs- und Randabstände und Gruppenfaktoren  $\alpha_g$

Anordnung	$c \geq$ [mm]	$s_{\perp} \geq$ [mm]	$\alpha_g$ [-]	Anordnung	$c \geq$ [mm]	$s_{\perp} \geq$ [mm]	$\alpha_g$ [-]
	115	-	-		115	-	-
	115	50	0,45		115	50	0,45
	115	115	2,0		115	115	2,0
Anordnung	$c \geq$ [mm]	$s_{\parallel}$ [mm]	$\alpha_g$ [-]	Anordnung	$c \geq$ [mm]	$s_{\parallel}$ [mm]	$\alpha_g$ [-]
	115	50	0,45		115	50	0,45
	115	115 (H)* 240 (S)*	2,0		115	115 (H)* 240 (S)*	2,0

\* (H) = Binder, (S) = Läufer

**Tabelle C23: Quertragfähigkeit bei Randabstand  $c \geq 50$  mm**

Dübeltyp und -größe	$h_{ef}$ [mm]	$f_b$ [N/mm <sup>2</sup> ]	$V_{Rk,b} = V_{Rk,c \parallel} = V_{Rk,c \perp}$ [kN]
Alle Dübel	$\geq 50$	12	3,0
		28	4,5

Zugehörige Achs- und Randabstände und Gruppenfaktoren  $\alpha_g$

Anordnung	$c \geq$ [mm]	$s_{\perp} \geq$ [mm]	$\alpha_g$ [-]	Anordnung	$c \geq$ [mm]	$s_{\perp} \geq$ [mm]	$\alpha_g$ [-]
	50	-	-		50	-	-
	50	115	2,0		50	115	2,0
Anordnung	$c \geq$ [mm]	$s_{\parallel}$ [mm]	$\alpha_g$ [-]	Anordnung	$c \geq$ [mm]	$s_{\parallel}$ [mm]	$\alpha_g$ [-]
	50	115 (H)* 240 (S)*	2,0		50	115 (H)* 240 (S)*	2,0

\* (H) = Binder, (S) = Läufer

**Tabelle C24: Verschiebungen**

$h_{ef}$	N	$\delta_{N0}$	$\delta_{N\infty}$	V	$\delta_{V0}$	$\delta_{V\infty}$
[mm]	[kN]	[mm]	[mm]	[kN]	[mm]	[mm]
$\geq 50$	2,5	0,3	0,6	2,5	1,0	1,5

Hilti HIT-HY 270 mit HAS-U

Leistung Kalksandvollstein KS, 2DF  
Charakteristische Werte der Tragfähigkeit unter Querlast und Gruppenfaktor  
Verschiebungen

Anhang C12







**Art des Mauersteins: Kalksandvollstein KS, 8DF**

**Tabelle C25: Beschreibung des Mauersteins**

Steintyp			Solid KS, 8DF	
Rohdichte	$\rho$	[kg/dm <sup>3</sup> ]	≥ 2,0	
Druckfestigkeit	$f_b$	[N/mm <sup>2</sup> ]	≥ 12 / 20 / 28	
Norm			EN 771 - 2	
Hersteller				
Steinabmessungen			≥ 248 x 240 x 248 [mm]	
Minimale Wanddicke	$h_{min}$	[mm]	≥ 240	

**Charakteristische Werte der Tragfähigkeit für alle Dübelkombinationen (siehe Tabelle B3)**

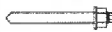
**Tabelle C26: Zugtragfähigkeit bei Randabstand  $c \geq 120$  mm**

Nutzungskategorie			w/w = w/d		d/d		
Gebrauchstemperaturbereich			Ta	Tb	Ta	Tb	
Dübeltyp und -größe	$h_{ef}$ [mm]	$f_b$ [N/mm <sup>2</sup> ]	$N_{Rk,p} = N_{Rk,b}$ [kN]				
Alle Dübel	≥ 50	12	-	-	7,0	5,5	
		20	-	-	9,0	7,5	
		28	-	-	10,5	8,5	
HAS-U  M8, M10	≥ 80	12	-	-	8,5	7,0	
		20	-	-	11,0	9,0	
		28	-	-	12,0	10,5	
HAS-U  M12	≥ 80	12	-	-	11,5	9,5	
		HAS-U + HIT-SC  + 	20	-	-	12,0	12,0
			28	-	-	12,0	12,0
HAS-U  M16	≥ 80	12	-	-	12,0	12,0	
		HAS-U + HIT-SC  + 	20	-	-	12,0	12,0
			28	-	-	12,0	12,0
HAS-U  M8, M10	≥ 100	12	-	-	12,0	11,0	
		20	-	-	12,0	12,0	
		28	-	-	12,0	12,0	

**Hilti HIT-HY 270 mit HAS-U**

**Leistung Kalksandvollstein KS, 8DF**  
Charakteristische Werte der Tragfähigkeit unter Zuglast und Gruppenfaktor

**Anhang C13**



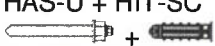

**Tabelle C26 fortgesetzt**

HAS-U 	M12, M16	≥ 100	12	-	-	12,0	12,0
HAS-U + HIT-SC 	M8 to M16		20	-	-	12,0	12,0
			28	-	-	12,0	12,0

Zugehörige Achs- und Randabstände und Gruppenfaktoren  $\alpha_g$

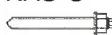
Anordnung	c ≥ [mm]	s <sub>⊥</sub> ≥ [mm]	$\alpha_g$ [-]	Anordnung	c ≥ [mm]	s <sub>  </sub> ≥ [mm]	$\alpha_g$ [-]
	120	-	-	-	-	-	-
	120	3 h <sub>ef</sub>	2,0		120	3 h <sub>ef</sub>	2,0

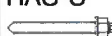
**Tabelle C27: Zugtragfähigkeit bei Randabstand c ≥ 50 mm**

Nutzungskategorie			w/w = w/d		d/d	
Gebrauchstemperaturbereich			Ta	Tb	Ta	Tb
Dübeltyp und -größe	h <sub>ef</sub> [mm]	f <sub>b</sub> [N/mm <sup>2</sup> ]	N <sub>RR,k,p</sub> = N <sub>RR,k,b</sub> [kN]			
Alle Dübel	≥ 50	12	-	-	4,0	3,5
		20	-	-	5,5	4,5
		28	-	-	6,5	5,0
HAS-U 	M8, M10	12	-	-	5,0	4,0
		20	-	-	6,5	5,5
		28	-	-	7,5	6,5
HAS-U 	M12	12	-	-	7,0	5,5
		20	-	-	9,0	7,5
		28	-	-	10,5	8,5
HAS-U + HIT-SC 	M8, M10	12	-	-	10,0	8,0
		20	-	-	12,0	10,5
		28	-	-	12,0	12,0
HAS-U 	M16	12	-	-	8,0	6,5
		20	-	-	10,5	8,5
		28	-	-	12,0	10,0
HAS-U + HIT-SC 	M12, M16	12	-	-	8,0	6,5
		20	-	-	10,5	8,5
		28	-	-	12,0	10,0
HAS-U 	M8, M10	12	-	-	8,0	6,5
		20	-	-	10,5	8,5
		28	-	-	12,0	10,0



Hilti HIT-HY 270 mit HAS-U

Leistung Kalksandvollstein KS, 8DF  
Charakteristische Werte der Tragfähigkeit unter Zuglast und Gruppenfaktor





Anhang C14

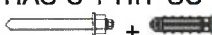

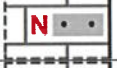

**Tabelle C27 fortgesetzt**

HAS-U 	M12	$\geq 100$	12	-	-	9,5	8,0
HAS-U + HIT-SC 	M8, M10		20	-	-	12,0	10,0
			28	-	-	12,0	12,0
HAS-U 	M16		12	-	-	12,0	10,5
HAS-U + HIT-SC 	M12, M16		20	-	-	12,0	12,0
			28	-	-	12,0	12,0







Zugehörige Achs- und Randabstände und Gruppenfaktoren  $\alpha_g$

Anordnung	$c \geq$ [mm]	$s_{\perp} \geq$ [mm]	$\alpha_g$ [-]	Anordnung	$c \geq$ [mm]	$s_{\parallel} \geq$ [mm]	$\alpha_g$ [-]
	50	-	-	-	-	-	-
	50	50	1,0		50	50	1,0
	50	3 h <sub>ef</sub>	2,0		50	3 h <sub>ef</sub>	2,0

**Tabelle C28: Quertragfähigkeit bei Randabstand  $c \geq 120$  mm (für  $V_{\parallel}$ ) und  $c \geq 1,5$  h<sub>ef</sub> (für  $V_{\perp}$ )**

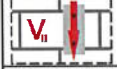
Dübeltyp und -größe	$h_{ef}$ [mm]	$f_b$ [N/mm <sup>2</sup> ]	$V_{RK,b} = V_{RK,c \parallel}$ [kN]	$V_{RK,c \perp}$
HAS-U 	$\geq 50$	12	9,0	Bemessung gemäß TR 054 Formel 10
		20	12,0	
		28	12,0	
HAS-U 		12	12,0	
		20	12,0	
HAS-U + HIT-SC 		M12, M16	28	

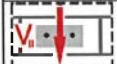
Zugehörige Achs- und Randabstände und Gruppenfaktoren  $\alpha_g$

Anordnung	$c \geq$ [mm]	$s_{\perp} \geq$ [mm]	$\alpha_g$ [-]	Anordnung	$c \geq$ [mm]	$s_{\perp} \geq$ [mm]	$\alpha_g$ [-]
	120	-	-		1,5 h <sub>ef</sub>	-	-
	120	3 h <sub>ef</sub>	2,0		1,5 h <sub>ef</sub>	3 h <sub>ef</sub>	2,0
Anordnung	$c \geq$ [mm]	$s_{\parallel}$ [mm]	$\alpha_g$ [-]	Anordnung	$c \geq$ [mm]	$s_{\parallel}$ [mm]	$\alpha_g$ [-]
	120	3 h <sub>ef</sub>	2,0		1,5 h <sub>ef</sub>	3 h <sub>ef</sub>	2,0

Hilti HIT-HY 270 mit HAS-U

Leistung Kalksandvollstein KS, 8DF  
Charakteristische Werte der Tragfähigkeit unter Zug- und Querlast und Gruppenfaktor

Anhang C15

**Tabelle C29: Quertragfähigkeit bei Randabstand  $c \geq 50$  mm**

Dübeltyp und -größe	$h_{ef}$ [mm]	$f_b$ [N/mm <sup>2</sup> ]	$V_{Rk,b} = V_{Rk,c II} = V_{Rk,c \perp}$ [kN]
Alle Dübel	$\geq 50$	12	3,0
		20	4,0
		28	4,5

Zugehörige Achs- und Randabstände und Gruppenfaktoren  $\alpha_g$

Anordnung	$c \geq$ [mm]	$s_{\perp} \geq$ [mm]	$\alpha_g$ [-]	Anordnung	$c \geq$ [mm]	$s_{\perp} \geq$ [mm]	$\alpha_g$ [-]
	50	-	-		50	-	-
	50	250	2,0		50	250	2,0
Anordnung	$c \geq$ [mm]	$s_{II}$ [mm]	$\alpha_g$ [-]	Anordnung	$c \geq$ [mm]	$s_{II}$ [mm]	$\alpha_g$ [-]
	50	250	2,0		50	250	2,0

**Tabelle C30: Verschiebungen**

$h_{ef}$	N	$\delta_{N0}$	$\delta_{N\infty}$	V	$\delta_{V0}$	$\delta_{V\infty}$
[mm]	[kN]	[mm]	[mm]	[kN]	[mm]	[mm]
50	2,3	0,10	0,20	3,4	2,8	4,2
80	3,4	0,15	0,30	3,4	2,8	4,2
100	3,4	0,15	0,30	3,4	2,8	4,2

Hilti HIT-HY 270 mit HAS-U

Leistung Kalksandvollstein KS, 8DF  
Charakteristische Werte der Tragfähigkeit unter Querlast und Gruppenfaktor  
Verschiebungen

Anhang C16

**Art des Mauersteins: Leichtbetonvollstein Vbl, 2DF**

**Tabelle C31: Beschreibung des Mauersteins**

Steintyp		Vbl, 2DF	
Rohdichte	$\rho$ [kg/dm <sup>3</sup> ]	$\geq 0,9$	
Druckfestigkeit	$f_b$ [N/mm <sup>2</sup> ]	$\geq 4 / 6$	
Norm		EN 771-3	
Hersteller			
Steinabmessungen	[mm]	$\geq 240 \times 115 \times 113$	
Minimale Wanddicke	$h_{min}$ [mm]	$\geq 115$	



**Charakteristische Werte der Tragfähigkeit für alle Dübelkombinationen (siehe Tabelle B3)**

**Tabelle C32: Zugtragfähigkeit bei Randabstand  $c \geq 115$  mm**

Nutzungskategorie			w/w = w/d		d/d	
Gebrauchstemperaturbereich			Ta	Tb	Ta	Tb
Dübeltyp und -größe	$h_{ef}$ [mm]	$f_b$ [N/mm <sup>2</sup> ]	$N_{RK,p} = N_{RK,b}$ [kN]			
Alle Dübel	$\geq 50$	4	3,0	2,0	3,0 (3,5*)	2,5
		6	3,5	3,0	4,0	3,0 (3,5*)
	$\geq 80$	4	4,5	3,5	5,0	4,0 (4,5*)
		6	5,5	4,5	6,0 (6,5*)	5,0 (5,5*)
	$\geq 100$	4	6,0	5,0	6,5 (7,0*)	5,5 (6,0*)
		6	7,5	6,0	8,0 (8,5*)	6,5 (7,0*)

\* nur CAC Reinigung







Zugehörige Achs- und Randabstände und Gruppenfaktoren  $\alpha_g$

Anordnung	$c \geq$ [mm]	$s_{\perp} \geq$ [mm]	$\alpha_g$ [-]	Anordnung	$c \geq$ [mm]	$s_{\parallel} \geq$ [mm]	$\alpha_g$ [-]
	115	-	-	-	-	-	-
	115	3 $h_{ef}$	2,0		115	3 $h_{ef}$	2,0

**Tabelle C33: Zugtragfähigkeit bei Randabstand  $c \geq 50$  mm**

Nutzungskategorie			w/w = w/d		d/d	
Gebrauchstemperaturbereich			Ta	Tb	Ta	Tb
Dübeltyp und -größe	$h_{ef}$ [mm]	$f_b$ [N/mm <sup>2</sup> ]	$N_{RK,p} = N_{RK,b}$ [kN]			
Alle Dübel	$\geq 50$	4	1,5	1,2	1,5	1,5
		6	2,0	1,5	2,0	1,5

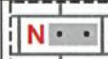
Zugehörige Achs- und Randabstände und Gruppenfaktoren  $\alpha_g$

Anordnung	$c \geq$ [mm]	$s_{\perp} \geq$ [mm]	$\alpha_g$ [-]	Anordnung	$c \geq$ [mm]	$s_{\parallel} \geq$ [mm]	$\alpha_g$ [-]
	50	-	-	-	-	-	-
	50	115	1,0		50	115	1,0
	115	50	1,0		115	50	1,0
	50	3 $h_{ef}$	2,0		50	3 $h_{ef}$	2,0

**Hilti HIT-HY 270 mit HAS-U**

**Leistung Leichtbetonvollstein Vbl, 2DF**  
Charakteristische Werte der Tragfähigkeit unter Zuglast und Gruppenfaktor

**Anhang C17**

**Tabelle C34: Quertragfähigkeit bei Randabstand  $c \geq 115$  mm (für  $V_{II}$ ) und  $c \geq 1,5$  hef (für  $V_{\perp}$ )**

Dübeltyp und -größe	hef [mm]	$f_b$ [N/mm <sup>2</sup> ]	$V_{RK,b} = V_{RK,c II}$ [kN]	$V_{RK,c \perp}$
HAS-U M8	$\geq 50$	4	2,0	Bemessung gemäß TR 054 Formel 10
		6	2,5	
HAS-U M10 to M16		4	2,5	
		6	3,0	

Zugehörige Achs- und Randabstände und Gruppenfaktoren  $\alpha_g$

Anordnung	$c \geq$ [mm]	$s_{\perp} \geq$ [mm]	$\alpha_g$ [-]	Anordnung	$c \geq$ [mm]	$s_{\perp} \geq$ [mm]	$\alpha_g$ [-]
	115	-	-		$1,5 h_{ef}$	-	-
	115	$3 h_{ef}$	2,0		$1,5 h_{ef}$	$3 h_{ef}$	2,0
Anordnung	$c \geq$ [mm]	$s_{II}$ [mm]	$\alpha_g$ [-]	Anordnung	$c \geq$ [mm]	$s_{II}$ [mm]	$\alpha_g$ [-]
	115	$3 h_{ef}$	2,0		$1,5 h_{ef}$	$3 h_{ef}$	2,0

**Tabelle C35: Quertragfähigkeit bei Randabstand  $c \geq 50$  mm**

Dübeltyp und -größe	hef [mm]	$f_b$ [N/mm <sup>2</sup> ]	$V_{RK,b} = V_{RK,c II} = V_{RK,c \perp}$ [kN]
Alle Dübel	$\geq 50$	4	1,20
		6	1,50

Zugehörige Achs- und Randabstände und Gruppenfaktoren  $\alpha_g$

Anordnung	$c \geq$ [mm]	$s_{\perp} \geq$ [mm]	$\alpha_g$ [-]	Anordnung	$c \geq$ [mm]	$s_{\perp} \geq$ [mm]	$\alpha_g$ [-]
	50	-	-		50	-	-
	115	50	1,0		115	50	1,0
	50	115	1,0		50	115	1,0
	50	$3 h_{ef}$	2,0		50	$3 h_{ef}$	2,0
Anordnung	$c \geq$ [mm]	$s_{II}$ [mm]	$\alpha_g$ [-]	Anordnung	$c \geq$ [mm]	$s_{II}$ [mm]	$\alpha_g$ [-]
	115	50	1,0		115	50	1,0
	50	115	1,0		50	115	1,0
	50	$3 h_{ef}$	2,0		50	$3 h_{ef}$	2,0

**Tabelle C36: Verschiebungen**

hef	N	$\delta_{N0}$	$\delta_{N\infty}$	V	$\delta_{V0}$	$\delta_{V\infty}$
[mm]	[kN]	[mm]	[mm]	[kN]	[mm]	[mm]
$\geq 50$	2,5	0,3	0,6	1,8	2,0	3,0

Hilti HIT-HY 270 mit HAS-U

Leistung Leichtbetonvollstein Vbl, 2DF

Charakteristische Werte der Tragfähigkeit unter Querlast und Gruppenfaktor  
Verschiebungen

Anhang C18

**Art des Mauersteins: Normalbetonvollstein Vbn, 2DF**

**Tabelle C37: Beschreibung des Mauersteins**



Steintyp		Vbn, 2DF	
Rohdichte	$\rho$ [kg/dm <sup>3</sup> ]	$\geq 2,0$	
Druckfestigkeit	$f_b$ [N/mm <sup>2</sup> ]	$\geq 6$ oder $\geq 16$	
Norm		EN 771-3	
Hersteller			
Steinabmessungen	[mm]	$\geq 240 \times 115 \times 113$	
Minimale Wanddicke	$h_{min}$ [mm]	$\geq 115$	

**Charakteristische Werte der Tragfähigkeit für alle Dübelkombinationen (siehe Tabelle B3)**

**Tabelle C38: Zugtragfähigkeit bei Randabstand  $c \geq 115$  mm**

Nutzungskategorie			w/w = w/d		d/d	
Gebrauchstemperaturbereich			Ta	Tb	Ta	Tb
Dübeltyp und -größe	$h_{ef}$ [mm]	$f_b$ [N/mm <sup>2</sup> ]	$N_{Rk,p} = N_{Rk,b}$ [kN]			
Alle Dübel	$\geq 50$	6	3,0	2,5	3,0	2,5
		16	5,5	4,5	5,5	4,5







Zugehörige Achs- und Randabstände und Gruppenfaktoren  $\alpha_g$

Anordnung	$c \geq$ [mm]	$s_{\perp} \geq$ [mm]	$\alpha_g$ [-]	Anordnung	$c \geq$ [mm]	$s_{\parallel} \geq$ [mm]	$\alpha_g$ [-]
	115	-	-	-	-	-	-
	115	$3 h_{ef}$	2,0		115	$3 h_{ef}$	2,0

**Tabelle C39: Zugtragfähigkeit bei Randabstand  $c \geq 50$  mm**

Nutzungskategorie			w/w = w/d		d/d	
Gebrauchstemperaturbereich			Ta	Tb	Ta	Tb
Dübeltyp und -größe	$h_{ef}$ [mm]	$f_b$ [N/mm <sup>2</sup> ]	$N_{Rk,p} = N_{Rk,b}$ [kN]			
Alle Dübel	$\geq 50$	6	1,5	1,2	1,5	1,2
		16	2,5	2,0	2,5	2,0

Zugehörige Achs- und Randabstände und Gruppenfaktoren  $\alpha_g$

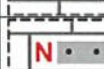
Anordnung	$c \geq$ [mm]	$s_{\perp} \geq$ [mm]	$\alpha_g$ [-]	Anordnung	$c \geq$ [mm]	$s_{\parallel} \geq$ [mm]	$\alpha_g$ [-]
	50	-	-	-	-	-	-
	50	115	1,0		50	115	1,0
	115	50	1,0		115	50	1,0
	50	$3 h_{ef}$	2,0		50	$3 h_{ef}$	2,0

Hilti HIT-HY 270 mit HAS-U

Leistung Normalbetonvollstein Vbn, 2DF  
Charakteristische Werte der Tragfähigkeit unter Zuglast und Gruppenfaktor

Anhang C19

**Tabelle C40: Quertragfähigkeit bei Randabstand  $c \geq 115$  mm (für  $V_{||}$ ) und  $c \geq 1,5 h_{ef}$  (für  $V_{\perp}$ )**

Dübeltyp und -größe	$h_{ef}$ [mm]	$f_b$ [N/mm <sup>2</sup> ]	$V_{RK,b} = V_{RK,c  }$ [kN]	$V_{RK,c\perp}$
Alle Dübel	$\geq 50$	6	4,0	Bemessung gemäß TR 054 Formel 10
		16	6,5	

Zugehörige Achs- und Randabstände und Gruppenfaktoren  $\alpha_g$

Anordnung	$c \geq$ [mm]	$s_{\perp} \geq$ [mm]	$\alpha_g$ [-]	Anordnung	$c \geq$ [mm]	$s_{\perp} \geq$ [mm]	$\alpha_g$ [-]
	115	-	-		$1,5 h_{ef}$	-	-
	115	$3 h_{ef}$	2,0		$1,5 h_{ef}$	$3 h_{ef}$	2,0
Anordnung	$c \geq$ [mm]	$s_{  }$ [mm]	$\alpha_g$ [-]	Anordnung	$c \geq$ [mm]	$s_{  }$ [mm]	$\alpha_g$ [-]
	115	$3 h_{ef}$	2,0		$1,5 h_{ef}$	$3 h_{ef}$	2,0

**Tabelle C41: Quertragfähigkeit bei Randabstand  $c \geq 50$  mm**

Dübeltyp und -größe	$h_{ef}$ [mm]	$f_b$ [N/mm <sup>2</sup> ]	$V_{RK,b} = V_{RK,c  } = V_{RK,c\perp}$
Alle Dübel	$\geq 50$	4	1,5
		6	3,0

Zugehörige Achs- und Randabstände und Gruppenfaktoren  $\alpha_g$

Anordnung	$c \geq$ [mm]	$s_{\perp} \geq$ [mm]	$\alpha_g$ [-]	Anordnung	$c \geq$ [mm]	$s_{\perp} \geq$ [mm]	$\alpha_g$ [-]
	50	-	-		50	-	-
	115	50	1,0		115	50	1,0
	50	115	1,0		50	115	1,0
	50	$3 h_{ef}$	2,0		50	$3 h_{ef}$	2,0
Anordnung	$c \geq$ [mm]	$s_{  }$ [mm]	$\alpha_g$ [-]	Anordnung	$c \geq$ [mm]	$s_{  }$ [mm]	$\alpha_g$ [-]
	115	50	1,0		115	50	1,0
	50	115	1,0		50	115	1,0
	50	$3 h_{ef}$	2,0		50	$3 h_{ef}$	2,0

**Tabelle C42: Verschiebungen**

$h_{ef}$	N	$\delta_{N0}$	$\delta_{N\infty}$	V	$\delta_{V0}$	$\delta_{V\infty}$
[mm]	[kN]	[mm]	[mm]	[kN]	[mm]	[mm]
$\geq 50$	1,5	0,3	0,6	1,8	2,0	3,0

Hilti HIT-HY 270 mit HAS-U

Leistung Normalbetonvollstein Vbn, 2DF  
Charakteristische Werte der Tragfähigkeit unter Querlast und Gruppenfaktor  
Verschiebungen

Anhang C20

**Art des Mauersteins: Lochziegel Hlz, 10DF**

**Tabelle C43: Beschreibung des Mauersteins**

Steintyp		Hlz12-1,4-10 DF	 <p>Steinzeichnung siehe Tabelle B4</p>	
Rohdichte	$\rho$	[kg/dm <sup>3</sup> ]		$\geq 1,4$
Druckfestigkeit	$f_b$	[N/mm <sup>2</sup> ]		$\geq 12 / 20$
Norm		EN 771 - 1		
Hersteller		Rapis (D)		
Steinabmessungen		[mm]		300 x 240 x 238
Minimale Wanddicke	$h_{min}$	[mm]		$\geq 240$



**Charakteristische Werte der Tragfähigkeit für alle Dübelkombinationen (siehe Tabelle B3)**

**Tabelle C44: Zugtragfähigkeit bei Randabstand  $c \geq 150$  mm**

Nutzungskategorie			w/w = w/d		d/d	
Gebrauchstemperaturbereich			Ta	Tb	Ta	Tb
Dübeltyp und -größe	$h_{ef}$ [mm]	$f_b$ [N/mm <sup>2</sup> ]	$N_{RK,p} = N_{RK,b}$ [kN]			
Alle Dübel	$\geq 80$	12	5,5 (6,0*)			
		20	7,0 (8,0*)			

\* nur CAC Reinigung

Zugehörige Achs- und Randabstände und Gruppenfaktoren  $\alpha_g$





Anordnung	$c \geq$ [mm]	$s_{\perp} \geq$ [mm]	$\alpha_g$ [-]	Anordnung	$c \geq$ [mm]	$s_{  } \geq$ [mm]	$\alpha_g$ [-]
	150	-	-	-	-	-	-
	150	240	2,0		150	300	2,0

**Tabelle C45: Zugtragfähigkeit bei Randabstand  $c \geq 50$  mm**

Nutzungskategorie			w/w = w/d		d/d	
Gebrauchstemperaturbereich			Ta	Tb	Ta	Tb
Dübeltyp und -größe	$h_{ef}$ [mm]	$f_b$ [N/mm <sup>2</sup> ]	$N_{RK,p} = N_{RK,b}$ [kN]			
Alle Dübel	$\geq 80$	12	1,5 (2,0*)			
		20	2,0 (2,5*)			

\* nur CAC Reinigung

Zugehörige Achs- und Randabstände und Gruppenfaktoren  $\alpha_g$

Anordnung	$c \geq$ [mm]	$s_{\perp} \geq$ [mm]	$\alpha_g$ [-]	Anordnung	$c \geq$ [mm]	$s_{  } \geq$ [mm]	$\alpha_g$ [-]
	50	-	-	-	-	-	-
	50	5 d <sub>0</sub>	1,0		50	5 d <sub>0</sub>	1,0
	50	240	2,0		50	300	2,0

Hilti HIT-HY 270 mit HAS-U

Leistung Lochziegel Hlz, 10DF  
Charakteristische Werte der Tragfähigkeit unter Zuglast und Gruppenfaktor

Anhang C21

**Tabelle C46: Quertragfähigkeit bei Randabstand  $c \geq 300$  mm**

Dübeltyp und -größe	$h_{ef}$ [mm]	$f_b$ [N/mm <sup>2</sup> ]	$V_{Rk,b} = V_{Rk,c,II} = V_{Rk,c,\perp}^{1)}$ [kN]
HAS-U M8, M10	$\geq 80$	12	4,5
		20	5,5
HAS-U M12, M16		12	9,5
		20	10

1)  $V_{Rk,b}$  kann als  $V_{Rk,c,\perp}$  eingesetzt werden wenn:  
 - die Lagerfugen vollständig mit Mörtel verfüllt sind und  
 - die Stoßfugen vollständig mit Mörtel verfüllt sind oder die Steine direkten Kontakt zueinander haben.

Zugehörige Achs- und Randabstände und Gruppenfaktoren  $\alpha_g$

Anordnung	$c \geq$ [mm]	$s_{\perp} \geq$ [mm]	$\alpha_g$ [-]	Anordnung	$c \geq$ [mm]	$s_{\perp} \geq$ [mm]	$\alpha_g$ [-]
	300	-	-		300	-	-
	300	240	2,0		300	240	1,0
Anordnung	$c \geq$ [mm]	$s_{II}$ [mm]	$\alpha_g$ [-]	Anordnung	$c \geq$ [mm]	$s_{II}$ [mm]	$\alpha_g$ [-]
	300	300	2,0		300	300	2,0

**Tabelle C47: Quertragfähigkeit bei Randabstand  $c \geq 50$  mm**

Dübeltyp und -größe	$h_{ef}$ [mm]	$c$ [mm]	$V_{Rk,c,\perp}$ [kN]
Alle Dübel	$\geq 80$	$\geq 50$	1,25
		$\geq 250$	2,5
		$c$ [mm]	$V_{Rk,b} = V_{Rk,c,II}$ [kN]
		$\geq 50$	1,25
		$\geq 100$ und $\geq 6 \cdot d_0$	2,5

Zugehörige Achs- und Randabstände und Gruppenfaktoren  $\alpha_g$

Anordnung	$c \geq$ [mm]	$s_{\perp} \geq$ [mm]	$\alpha_g$ [-]	Anordnung	$c \geq$ [mm]	$s_{\perp} \geq$ [mm]	$\alpha_g$ [-]
	siehe Tabelle C47	-	-		siehe Tabelle C47	-	-
	siehe Tabelle C47	$5 d_0$	1,0		siehe Tabelle C47	$5 d_0$	1,0
	siehe Tabelle C47	240	2,0		siehe Tabelle C47	240	2,0
Anordnung	$c \geq$ [mm]	$s_{II}$ [mm]	$\alpha_g$ [-]	Anordnung	$c \geq$ [mm]	$s_{II}$ [mm]	$\alpha_g$ [-]
	siehe Tabelle C47	$5 d_0$	1,0		siehe Tabelle C47	$5 d_0$	1,0
	siehe Tabelle C47	300	2,0		siehe Tabelle C47	300	2,0

**Tabelle C48: Verschiebungen**

$h_{ef}$	<b>N</b>	$\delta_{N0}$	$\delta_{N\infty}$	<b>V</b>	$\delta_{V0}$	$\delta_{V\infty}$
[mm]	[kN]	[mm]	[mm]	[kN]	[mm]	[mm]
$\geq 80$	2,5	0,4	0,8	1,7	1,0	1,5

Hilti HIT-HY 270 mit HAS-U

Leistung Lochziegel Hlz, 10DF  
 Charakteristische Werte der Tragfähigkeit unter Querlast und Gruppenfaktor  
 Verschiebungen

Anhang C22



**Art des Mauersteins: Kalksandlochstein KSL, 8DF**

**Tabelle C49: Beschreibung des Mauersteins**





Steintyp		KSL-12-1,4-8 DF	 <p>Steinzeichnung siehe Tabelle B4</p>	
Rohdichte	$\rho$	[kg/dm <sup>3</sup> ]		$\geq 1,4$
Druckfestigkeit	$f_b$	[N/mm <sup>2</sup> ]		$\geq 12 / 20$
Norm				EN 771 – 2
Hersteller				KS Wemding (D)
Steinabmessungen		[mm]		248 x 240 x 238
Minimale Wanddicke	$h_{min}$	[mm]		$\geq 240$

**Charakteristische Werte der Tragfähigkeit für alle Dübelkombinationen (siehe Tabelle B3)**

**Tabelle C50: Zugtragfähigkeit bei Randabstand  $c \geq 50$  mm**

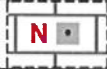
Nutzungskategorie			w/w = w/d		d/d	
Gebrauchstemperaturbereich			Ta	Tb	Ta	Tb
Dübeltyp und -größe	$h_{ef}$ [mm]	$f_b$ [N/mm <sup>2</sup> ]	$N_{Rk,p} = N_{Rk,b}$ [kN]			
HAS-U M8 bis M16	$\geq 80$	12	-	-	4,0	3,0
		20	-	-	5,5	4,5
	$\geq 130$	12	-	-	5,0	4,0
		20	-	-	7,5	6,0

Zugehörige Achs- und Randabstände und Gruppenfaktoren  $\alpha_g$

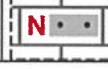
Anordnung	$c \geq$ [mm]	$s_{\perp} \geq$ [mm]	$\alpha_g$ [-]	Anordnung	$c \geq$ [mm]	$s_{  } \geq$ [mm]	$\alpha_g$ [-]
	50	-	-	-	-	-	-
	50	50	1,0		50	50	1,0
	50	240	2,0		50	250	2,0

**Tabelle C51: Quertragfähigkeit bei Randabstand  $c \geq 125$  mm (für  $V_{||}$ ) und  $c \geq 250$  mm (für  $V_{\perp}$ )**

Dübeltyp und -größe	$h_{ef}$ [mm]	$f_b$ [N/mm <sup>2</sup> ]	$V_{Rk,b} = V_{Rk,c  } = V_{Rk,c\perp}$ <sup>1)</sup> [kN]
HAS-U M8	$\geq 80$	12	6,0
		20	9,0
HAS-U M10		12	9,0
		20	12,0
HAS-U M12 to M16		12	12,0
		20	12,0

<sup>1)</sup>  $V_{Rk,b}$  darf als  $V_{Rk,c\perp}$  eingesetzt werden wenn:

- die Lagerfugen vollständig mit Mörtel verfüllt sind und
- die Stoßfugen vollständig mit Mörtel verfüllt sind oder die Steine direkten Kontakt zueinander haben und
- max  $V_{Rk,c\perp} = 9$  kN

Hilti HIT-HY 270 mit HAS-U

Leistung Kalksandlochstein KSL, 8DF  
Charakteristische Werte der Tragfähigkeit unter Zuglast und Gruppenfaktor

Anhang C23

Zugehörige Achs- und Randabstände und Gruppenfaktoren  $\alpha_g$

Anordnung	$c \geq$ [mm]	$s_{\perp} \geq$ [mm]	$\alpha_g$ [-]	Anordnung	$c \geq$ [mm]	$s_{\perp} \geq$ [mm]	$\alpha_g$ [-]
	125	-	-		250	-	-
	125	240	2,0	-	-	-	-
Anordnung	$c \geq$ [mm]	$s_{\parallel}$ [mm]	$\alpha_g$ [-]	Anordnung	$c \geq$ [mm]	$s_{\parallel}$ [mm]	$\alpha_g$ [-]
	125	250	2,0		250	250	2,0

**Tabelle C52: Quertragfähigkeit bei Randabstand  $c \geq 50$  mm**

Dübeltyp und -größe	$h_{ef}$ [mm]	$c$ [mm]	$f_b$ [N/mm <sup>2</sup> ]	$V_{RK,c,\perp}$ [kN]	
Alle Dübel	$\geq 80$	$\geq 50$	12	4,0	
			20	6,0	
		$c$ [mm]	$f_b$ [N/mm <sup>2</sup> ]	$V_{RK,b} = V_{RK,c,\parallel}$ [kN]	
				12	4,0
		$\geq 50$	20	6,0	

Zugehörige Achs- und Randabstände und Gruppenfaktoren  $\alpha_g$

Anordnung	$c \geq$ [mm]	$s_{\perp} \geq$ [mm]	$\alpha_g$ [-]	Anordnung	$c \geq$ [mm]	$s_{\perp} \geq$ [mm]	$\alpha_g$ [-]
	50	-	-		50	-	-
	50	50	1,0		50	50	1,0
	50	240	2,0		50	240	2,0
Anordnung	$c \geq$ [mm]	$s_{\parallel}$ [mm]	$\alpha_g$ [-]	Anordnung	$c \geq$ [mm]	$s_{\parallel}$ [mm]	$\alpha_g$ [-]
	50	50	1,0		50	50	1,0
	50	250	2,0		50	250	2,0

**Tabelle C53: Verschiebungen**

$h_{ef}$	$N$	$\delta_{N0}$	$\delta_{N\infty}$	$V$	$\delta_{V0}$	$\delta_{V\infty}$
[mm]	[kN]	[mm]	[mm]	[kN]	[mm]	[mm]
80	1,0	0,3	0,6	4,3	2,0	3,0
130	2,1	0,3	0,6	4,3	2,0	3,0

Hilti HIT-HY 270 mit HAS-U

Leistung Kalksandlochstein KSL, 8DF

Charakteristische Werte der Tragfähigkeit unter Querlast und Gruppenfaktor  
Verschiebungen

Anhang C24

**Art des Mauersteins: Leichtbeton Hohlblockstein Hbl, 16DF**

**Tabelle C54: Beschreibung des Mauersteins**

Steintyp		Hbl-4-0,7	 Steinzeichnung siehe Tabelle B4
Rohdichte	$\rho$ [kg/dm <sup>3</sup> ]	$\geq 0,7$	
Druckfestigkeit	$f_b$ [N/mm <sup>2</sup> ]	$\geq 2 / 6$	
Norm		EN 771-3	
Hersteller		Knobel (D)	
Steinabmessungen	[mm]	495 x 240 x 238	
Minimale Wanddicke	$h_{min}$ [mm]	$\geq 240$	



**Charakteristische Werte der Tragfähigkeit für alle Dübelkombinationen (siehe Tabelle B3)**

**Tabelle C55: Zugtragfähigkeit bei Randabstand  $c \geq 125$  mm**

Nutzungskategorie			w/w = w/d		d/d	
Gebrauchstemperaturbereich			Ta	Tb	Ta	Tb
Dübeltyp und -größe	$h_{ef}$ [mm]	$f_b$ [N/mm <sup>2</sup> ]	$N_{Rk,p} = N_{Rk,b}$ [kN]			
HAS-U M8 und M10,	$\geq 80$	2	3,5	3,0	4,0	3,0 (3,5*)
		6	6,0	5,0	6,5 (7,0*)	5,5 (6,0*)
HAS-U M12 und M16	$\geq 80$	2	4,0	3,5	4,5	3,5 (4,0*)
		6	7,0	6,0	8,0	6,5 (7,0*)

\* nur CAC Reinigung

Zugehörige Achs- und Randabstände und Gruppenfaktoren  $\alpha_g$

Anordnung	$c \geq$ [mm]	$s_{\perp} \geq$ [mm]	$\alpha_g$ [-]	Anordnung	$c \geq$ [mm]	$s_{\parallel} \geq$ [mm]	$\alpha_g$ [-]
	125	-	-	-	-	-	-
	125	240	2,0		125	240	2,0

**Hilti HIT-HY 270 mit HAS-U**

**Leistung Leichtbeton Hohlblockstein Hbl, 16DF**  
Charakteristische Werte der Tragfähigkeit unter Zuglast und Gruppenfaktor

**Anhang C25**

**Tabelle C56: Zugtragfähigkeit bei Randabstand  $c \geq 50$  mm**

Nutzungskategorie			w/w = w/d		d/d	
Gebrauchstemperaturbereich			Ta	Tb	Ta	Tb
Dübeltyp und -größe	$h_{ef}$ [mm]	$f_b$ [N/mm <sup>2</sup> ]	$N_{RK,p} = N_{RK,b}$ [kN]			
HAS-U M8 bis M16	$\geq 80$	2	1,5	1,2	1,5	1,5
		6	2,5	2,0	3,0	2,5
	160	2	2,0	1,5	2,0	1,5 (2,0*)
		6	3,5	2,5	3,5 (4,0*)	3,0

\* nur CAC Reinigung

Zugehörige Achs- und Randabstände und Gruppenfaktoren  $\alpha_g$

Anordnung	$c \geq$ [mm]	$s_{\perp} \geq$ [mm]	$\alpha_g$ [-]	Anordnung	$c \geq$ [mm]	$s_{  } \geq$ [mm]	$\alpha_g$ [-]
	50	-	-	-	-	-	-
	50	50	1,0		50	50	1,0
	50	240	2,0		50	240	2,0

**Tabelle C57: Quertragfähigkeit bei Randabstand  $c \geq 250$  mm (für  $V_{||}$ ) und  $c \geq 500$  mm (für  $V_{\perp}$ )**

Dübeltyp und -größe	$h_{ef}$ [mm]	$f_b$ [N/mm <sup>2</sup> ]	$V_{RK,b} = V_{RK,c  } = V_{RK,c\perp}$ <sup>1)</sup> [kN]
HAS-U M8, M10	$\geq 80$	2	4,0
		6	6,5
HAS-U M12	$\geq 80$	2	5,5
		6	9,5
HAS-U M16	$\geq 80$	2	6,0
		6	10,0

<sup>1)</sup>  $V_{RK,b}$  darf als  $V_{RK,c\perp}$  eingesetzt werden, wenn:

- die Lagerfugen vollständig mit Mörtel verfüllt sind und
- die Stoßfugen vollständig mit Mörtel verfüllt sind oder die Steine direkten Kontakt zueinander haben.

Zugehörige Achs- und Randabstände und Gruppenfaktoren  $\alpha_g$

Anordnung	$c \geq$ [mm]	$s_{\perp} \geq$ [mm]	$\alpha_g$ [-]	Anordnung	$c \geq$ [mm]	$s_{\perp} \geq$ [mm]	$\alpha_g$ [-]
	250	-	-		500	-	-
	250	240	2,0		500	240	1,0
Anordnung	$c \geq$ [mm]	$s_{  }$ [mm]	$\alpha_g$ [-]	Anordnung	$c \geq$ [mm]	$s_{  }$ [mm]	$\alpha_g$ [-]
	250	250	2,0		500	500	2,0

Hilti HIT-HY 270 mit HAS-U

Leistung Leichtbeton Hohlblockstein Hbl, 16DF

Charakteristische Werte der Tragfähigkeit unter Zug- und Querlast und Gruppenfaktor

Anhang C26

**Tabelle C58: Quertragfähigkeit bei Randabstand  $c \geq 50$  mm**

Dübeltyp und -größe	$h_{ef}$ [mm]	$c$ [mm]	$f_b$ [N/mm <sup>2</sup> ]	$V_{Rk,c,\perp}$ [kN]
Alle Dübel	$\geq 80$	$\geq 50$	2	1,5
			6	3,0
		$\geq 250$	2	2,5
			$c$ [mm]	$f_b$ [N/mm <sup>2</sup> ]
		$\geq 50$	2	1,5
			6	3,0
$\geq 100$ $\geq 6 d_0$	2	2,5		

Zugehörige Achs- und Randabstände und Gruppenfaktoren  $\alpha_g$

Anordnung	$c \geq$ [mm]	$s_{\perp} \geq$ [mm]	$\alpha_g$ [-]	Anordnung	$c \geq$ [mm]	$s_{\perp} \geq$ [mm]	$\alpha_g$ [-]
	siehe Tabelle C58	-	-		siehe Tabelle C58	-	-
	siehe Tabelle C58	50	1,0		siehe Tabelle C58	50	1,0
	siehe Tabelle C58	240	2,0		siehe Tabelle C58	240	2,0
Anordnung	$c \geq$ [mm]	$s_{\parallel}$ [mm]	$\alpha_g$ [-]	Anordnung	$c \geq$ [mm]	$s_{\parallel}$ [mm]	$\alpha_g$ [-]
	siehe Tabelle C58	50	1,0		siehe Tabelle C58	50	1,0
	siehe Tabelle C58	250	2,0		siehe Tabelle C58	250	2,0

**Tabelle C59: Verschiebungen**

$h_{ef}$	<b>N</b>	$\delta_{N0}$	$\delta_{N\infty}$	<b>V</b>	$\delta_{V0}$	$\delta_{V\infty}$
[mm]	[kN]	[mm]	[mm]	[kN]	[mm]	[mm]
80	0,8	0,20	0,4	2,3	1,0	1,5
160	1,1	0,25	0,5	2,3	1,0	1,5

Hilti HIT-HY 270 mit HAS-U

Leistung Leichtbeton Hohlblockstein Hbl, 16DF  
Charakteristische Werte der Tragfähigkeit unter Querlast und Gruppenfaktor  
Verschiebungen

Anhang C27

**Art des Mauersteins: Normalbeton Lochstein - parpaing creux**

**Tabelle C60: Beschreibung des Mauersteins**

Steintyp		B40	 Steinzeichnung siehe Tabelle B4
Rohdichte	$\rho$ [kg/dm <sup>3</sup> ]	≥ 0,9	
Druckfestigkeit	$f_b$ [N/mm <sup>2</sup> ]	≥ 4 oder ≥ 10	
Norm		EN 771-3	
Hersteller		Fabemi (F)	
Steinabmessungen	[mm]	500 x 200 x 200	
Minimale Wanddicke	$h_{min}$ [mm]	≥ 200	

**Charakteristische Werte der Tragfähigkeit für alle Dübelkombinationen (siehe Tabelle B3)**

**Tabelle C61: Zugtragfähigkeit bei Randabstand  $c \geq 50$  mm**

Nutzungskategorie			w/w = w/d		d/d	
Gebrauchstemperaturbereich			Ta	Tb	Ta	Tb
Dübeltyp und -größe	$h_{ef}$ [mm]	$f_b$ [N/mm <sup>2</sup> ]	$N_{Rk,p} = N_{Rk,b}$ [kN]			
Alle Dübel	≥ 50	4	0,9	0,9	0,9	0,9
		10	2,0	1,5	2,0	1,5
Alle Dübel	≥ 130	4	1,5	1,2	1,5	1,2
		10	2,5	2,0	2,5	2,0

Zugehörige Achs- und Randabstände und Gruppenfaktoren  $\alpha_g$

Anordnung	$c \geq$ [mm]	$s_{\perp} \geq$ [mm]	$\alpha_g$ [-]	Anordnung	$c \geq$ [mm]	$s_{\parallel} \geq$ [mm]	$\alpha_g$ [-]
	50	-	-	-	-	-	-
	50	200	2,0		50	200	2,0

**Tabelle C62: Quertragfähigkeit bei Randabstand  $c \geq 200$  mm (für  $V_{II}$ ) und  $c \geq 500$  mm (für  $V_{\perp}$ )**

Dübeltyp und -größe	$h_{ef}$ [mm]	$f_b$ [N/mm <sup>2</sup> ]	$V_{Rk,b} = V_{Rk,c \parallel} = V_{Rk,c \perp}$ <sup>1)</sup> [kN]
Alle Dübel	≥ 50	4	4
		10	6,5
	≥ 80	4	5
		10	7,5

<sup>1)</sup>  $V_{Rk,b}$  darf als  $V_{Rk,c \perp}$  eingesetzt werden, wenn:

- die Lagerfugen vollständig mit Mörtel verfüllt sind und
- die Stoßfugen vollständig mit Mörtel verfüllt sind oder die Steine direkten Kontakt zueinander haben.

Hilti HIT-HY 270 mit HAS-U

Leistung Normalbeton Lochstein - parpaing creux  
Charakteristische Werte der Tragfähigkeit unter Zug- und Querlast und Gruppenfaktor

Anhang C28

Zugehörige Achs- und Randabstände und Gruppenfaktoren  $\alpha_g$

Anordnung	$c \geq$ [mm]	$s_{\perp} \geq$ [mm]	$\alpha_g$ [-]	Anordnung	$c \geq$ [mm]	$s_{\perp} \geq$ [mm]	$\alpha_g$ [-]
	200	-	-		500	-	-
	200	200	2,0		500	200	1,0
Anordnung	$c \geq$ [mm]	$s_{\parallel}$ [mm]	$\alpha_g$ [-]	Anordnung	$c \geq$ [mm]	$s_{\parallel}$ [mm]	$\alpha_g$ [-]
	200	200	2,0		500	500	2,0

**Tabelle C63: Quertragfähigkeit bei Randabstand  $c \geq 50$  mm**

Dübeltyp und -größe	$h_{ef}$ [mm]	$c$ [mm]	$f_b$ [N/mm <sup>2</sup> ]	$V_{Rk,c,\perp}$ [kN]
Alle Dübel	$\geq 50$	$\geq 50$	4	1,2
			10	1,5
		$\geq 250$	4/10	2,5
		$c$ [mm]	$f_b$ [N/mm <sup>2</sup> ]	$V_{Rk,b} = V_{Rk,c,\parallel}$ [kN]
		$\geq 50$	4	2,0
			10	3,0

Zugehörige Achs- und Randabstände und Gruppenfaktoren  $\alpha_g$

Anordnung	$c \geq$ [mm]	$s_{\perp} \geq$ [mm]	$\alpha_g$ [-]	Anordnung	$c \geq$ [mm]	$s_{\perp} \geq$ [mm]	$\alpha_g$ [-]
	50	-	-		siehe Tabelle C63	-	-
	50	50	1,0		siehe Tabelle C63	50	1,0
	50	200	2,0		siehe Tabelle C63	200	2,0
Anordnung	$c \geq$ [mm]	$s_{\parallel}$ [mm]	$\alpha_g$ [-]	Anordnung	$c \geq$ [mm]	$s_{\parallel}$ [mm]	$\alpha_g$ [-]
	50	50	1,0		siehe Tabelle C63	50	1,0
	50	200	2,0		siehe Tabelle C63	200	2,0

**Tabelle C64: Verschiebungen**

$h_{ef}$	$N$	$\delta_{N0}$	$\delta_{N\infty}$	$V$	$\delta_{V0}$	$\delta_{V\infty}$
[mm]	[kN]	[mm]	[mm]	[kN]	[mm]	[mm]
$\geq 50$	0,7	0,5	1,0	1,7	1,0	1,5

Hilti HIT-HY 270 mit HAS-U

Leistung Normalbeton Lochstein - parpaing creux  
Charakteristische Werte der Tragfähigkeit unter Querlast und Gruppenfaktor  
Verschiebungen

Anhang C29

**Art des Mauersteins: Deckenziegel**

**Tabelle C65: Beschreibung des Deckenziegels**

Steintyp		Ds-1,0	 Steinzeichnung siehe Tabelle B4
Rohdichte	$\rho \geq$ [kg/dm <sup>3</sup> ]	1,0	
Festigkeit		DIN EN 15037-3, Klasse R2	
Norm		DIN 4160	
Hersteller		Fiedler Marktredwitz (D)	
Steinabmessungen	[mm]	510 x 250 x 180	
Minimale Deckendicke	$h_{\min} \geq$ [mm]	$\geq 180$	

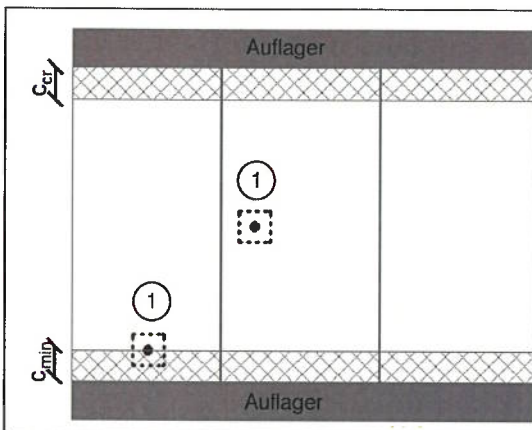

① Einzelbefestigung  
Maximal ein Dübel pro Deckenziegel

**Tabelle C66: Montageparameter für alle Dübelkombinationen (siehe Tabelle B3)**

Befestigungselement		HAS-U M6 mit HIT-SC 12x85
Randabstand	$c_{\min} = c_{cr}$ [mm]	100 vom Auflager
Achsabstand	$s_{\min \parallel}$ [mm]	510
	$s_{\min \perp} = s_{cr}$ [mm]	250

**Tabelle C67: Gruppenfaktor**

Gruppenfaktor	$\alpha_{g,N \parallel} \alpha_{g,V \parallel} \alpha_{g,N \perp} \alpha_{g,V \perp}$ [-]	1
---------------	---	---

**Tabelle C68: Zugtragfähigkeit für alle Dübelkombinationen (siehe Tabelle B3)**

Nutzungskategorie			w/w		d/d	
Gebrauchstemperaturbereich			Ta	Tb	Ta	Tb
Dübeltyp und -größe	$h_{ef}$ [mm]	Konsolentragfähigkeit [kN]	$N_{Rk,p} = N_{Rk,b}$ [kN]			
Alle Dübel	$\geq 80$	3	1,5	1,5	1,5	1,5

**Tabelle C69: Verschiebungen**

$h_{ef}$	N	$\delta_{N0}$	$\delta_{N\infty}$
[mm]	[kN]	[mm]	[mm]
$\geq 80$	0,4	0,15	0,30

Hilti HIT-HY 270 mit HAS-U

Leistung Deckenziegel  
Montageparameter und Gruppenfaktor  
Charakteristische Werte der Tragfähigkeit unter Zuglast und Verschiebungen

Anhang C30





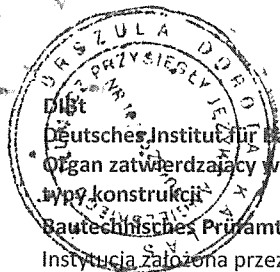

Deutsches Institut für Bautechnik  
Organ zatwierdzający wyroby budowlane oraz  
typy konstrukcji  
Bautechnisches Prüfamt  
Instytucja założona przez rządy federalne oraz rządy  
krajów związkowych

Jednostka autoryzowana  
na podstawie art. 29  
Rozporządzenia (UE)  
nr 305/2011 oraz członek  
Europejskiej Organizacji  
ds. Oceny Technicznej (EOTA)

## Europejska Ocena Techniczna ETA-19/0160 z 30 sierpnia 2019 r.

Tłumaczenie na język angielski opracowane przez Niemiecki Instytut Techniki Budowlanej (DIBt) – wersja oryginalna w języku niemieckim  
Tłumaczenie z języka angielskiego na język polski wykonano na zlecenie Hilti

### Część ogólna

Jednostka Oceny Technicznej wydająca Europejską Ocenę Techniczną:	Deutsches Institut für Bautechnik
Nazwa handlowa wyrobu budowlanego	Hilti HIT-HY 270 z HAS-U
Rodzina wyrobów, do których należy wyrób budowlany	Metalowe kotwy wklejane do stosowania w podłożu murowym
Producent	Hilti Aktiengesellschaft 9494 SCHAAN FÜRSTENTUM LIECHTENSTEIN
Zakład produkcyjny	Hilti Werke
Niniejsza Europejska Ocena Techniczna zawiera	51 stron, w tym 3 załączniki stanowiące integralną część oceny technicznej
Niniejsza Europejska Ocena Techniczna została wydana zgodnie z Rozporządzeniem (UE) nr 305/2011 na podstawie	EDO 330076-00-0604
Niniejsza wersja zastępuje	ETA-19/0160 z dnia 29 kwietnia 2019 r.

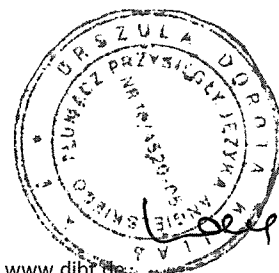

**Europejska Ocena Techniczna**  
**ETA-19/0160**

Tłumaczenie na język angielski opracowane przez DIBt  
Tłumaczenie z języka angielskiego na język polski wykonano na zlecenie Hilti

**Strona 2 z 51 | 30 sierpnia 2019 r.**

Niniejsza Europejska Ocena Techniczna została wydana przez Jednostkę Oceny Technicznej w języku urzędowym tej jednostki. Tłumaczenia niniejszej Europejskiej Oceny Technicznej na inne języki powinny w pełni odpowiadać oryginalnie wydanemu dokumentowi i powinny być oznaczone jako tłumaczenia.

Niniejsza Europejska Ocena Techniczna, włączając w to jej formy elektroniczne, może być rozpowszechniana wyłącznie w całości. Jakkolwiek publikowanie części dokumentu jest możliwe wyłącznie za pisemną zgodą Jednostki Oceny Technicznej. W tym przypadku na kopii powinna być podana informacja, że jest to fragment dokumentu.

Niniejsza Europejska Ocena Techniczna może zostać wycofana przez wydającą ją Jednostkę Oceny Technicznej, w szczególności na podstawie informacji Komisji zgodnie z Artykułem 25(3) Rozporządzenia (UE) nr 305/2011.

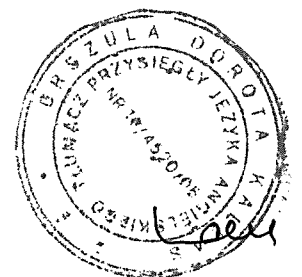

**Europejska Ocena Techniczna**

**ETA-19/0160**

Tłumaczenie na język angielski opracowane przez DIBt

Tłumaczenie z języka angielskiego na język polski wykonano na zlecenie Hilti

**Strona 3 z 51 | 30 sierpnia 2019 r.**

**Część szczegółowa**

**1 Opis techniczny produktu**

System iniekcyjny Hilti HIT-HY 270 z HAS-U do konstrukcji murowych stanowi kotwę wklejaną (iniekcijną) obejmującą opakowanie foliowe z żywicą iniekcijną HIT-HY 270, tuleję siatkową oraz pręt kotwiący z nakrętką sześciokątną oraz podkładką w rozmiarach od M6 do M16. Elementy stalowe są wykonane ze stali cynkowej, stali nierdzewnej lub stali o wysokiej odporności na korozję.

Pręt kotwiący jest umieszczany w wywierconym otworze wypełnionym żywicą iniekcijną oraz kotwiony przez wiązanie adhezyjne i/lub połączenie kształtowe pomiędzy elementem stalowym, żywicą iniekcijną oraz konstrukcją murową.

Opis produktu został zamieszczony w Załączniku A.

**2 Określenie zamierzonego zastosowania, zgodnie z odpowiednim Europejskim Dokumentem Oceny (EDO)**

Właściwości użytkowe podane w Rozdziale 3 obowiązują wyłącznie wtedy, gdy kotwa jest stosowana zgodnie ze specyfikacjami i warunkami podanymi w Załączniku B.

Weryfikacja i metody oceny, na których oparta jest niniejsza Europejska Ocena Techniczna, zakładają okres użytkowania kotwy wynoszący co najmniej 50 lat. Wskazania dotyczące okresu użytkowania nie mogą być interpretowane jako gwarancja udzielona przez producenta, a jedynie jako przesłanki mające pomóc w wyborze odpowiedniego produktu spełniającego oczekiwania z punktu widzenia ekonomicznie optymalnego czasu eksploatacji wykonanych robót.

**3 Właściwości użytkowe wyrobu oraz metody zastosowane do ich oceny**

**3.1 Nośność i stateczność (podstawowe wymagania 1)**

Zasadnicze charakterystyki	Właściwości użytkowe
Wartości charakterystyczne nośności	Patrz Załączniki C1-C30
Przemieszczenia	Patrz Załączniki C4-C30
Trwałość	Patrz Załącznik B2

**3.2 Bezpieczeństwo pożarowe (podstawowe wymagania 2)**

Zasadnicze charakterystyki	Właściwości użytkowe
Reakcja na ogień	Klasa A1

**3.3 Higiena, zdrowie i środowisko (podstawowe wymagania 3)**

Zasadnicze charakterystyki	Właściwości użytkowe
Zawartość, emisja i/lub uwalnianie niebezpiecznych substancji	Nie oceniano właściwości użytkowych w tym zakresie

**4 System oceny i weryfikacji stałości właściwości użytkowych (AVCP) wraz z odniesieniem do jego podstawy prawnej**

Zgodnie z Europejskim Dokumentem Oceny (EDO) nr 330076-00-0604, właściwy europejski akt prawny to: [97/177/WE].

Zastosowanie ma system: 1

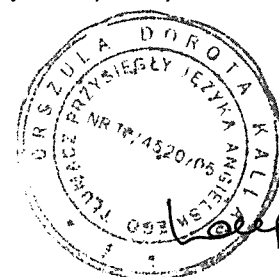

**Europejska Ocena Techniczna  
ETA-19/0160**

Tłumaczenie na język angielski opracowane przez DIBt  
Tłumaczenie z języka angielskiego na język polski wykonano na zlecenie Hilti

Strona 4 z 51 | 30 sierpnia 2019 r.

**5 Szczegóły techniczne niezbędne do wdrożenia systemu AVCP, zgodnie z właściwym Europejskim Dokumentem Oceny (EDO)**

Szczegóły techniczne niezbędne do wdrożenia systemu AVCP zostały określone w planie kontroli złożonym w Deutsches Institut für Bautechnik.

Dokument wydany w Berlinie 30 sierpnia 2019 r. przez Deutsches Institut für Bautechnik.

BD Dipl.-Ing. Andreas Kummerow

*uwierzytelnione przez:*

Kierownik Działu

Lange

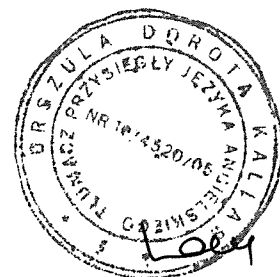

### Warunki montażu

**Rys. A1:** Cegła otworowa i pełna z HAS-U-... i jedną tuleją siatkową HIT-SC (patrz Tabela B5)

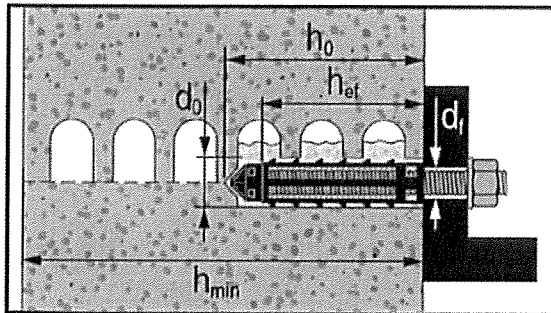

**Rys. A2:** Cegła otworowa i pełna z HAS-U-... i dwoma tulejami siatkowymi HIT-SC dla większych głębokości osadzenia (patrz Tabela B6)

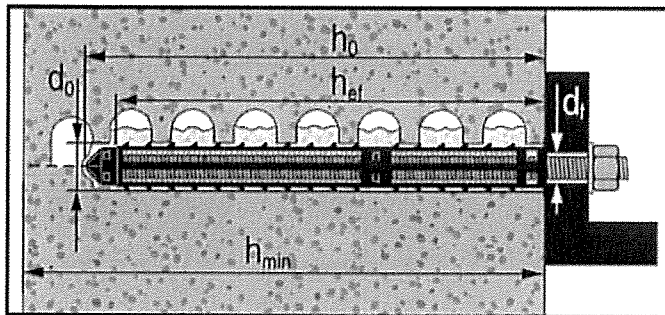

**Rys. A3:** Cegła pełna z HAS-U-... (patrz Tabela B7)

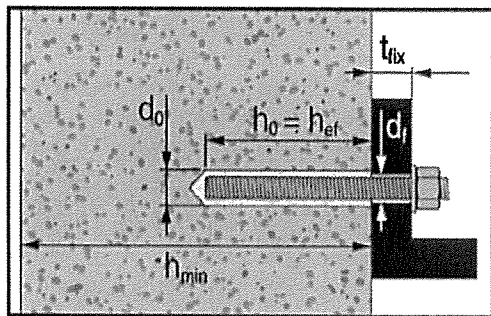

Hilti HIT-HY 270 z HAS-U

Opis wyrobu  
Warunki montażu

Załącznik A1

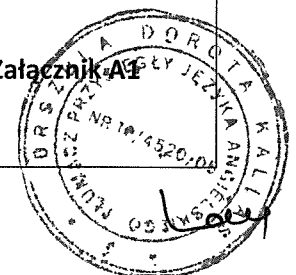

**Rys. A4:** Cegła otworowa i pełna z HAS-U-... i dwoma tulejami siatkowymi HIT-SC do zakotwienia przelotowego przez element mocowany i/lub przez warstwę nienośną (patrz Tabela B8)

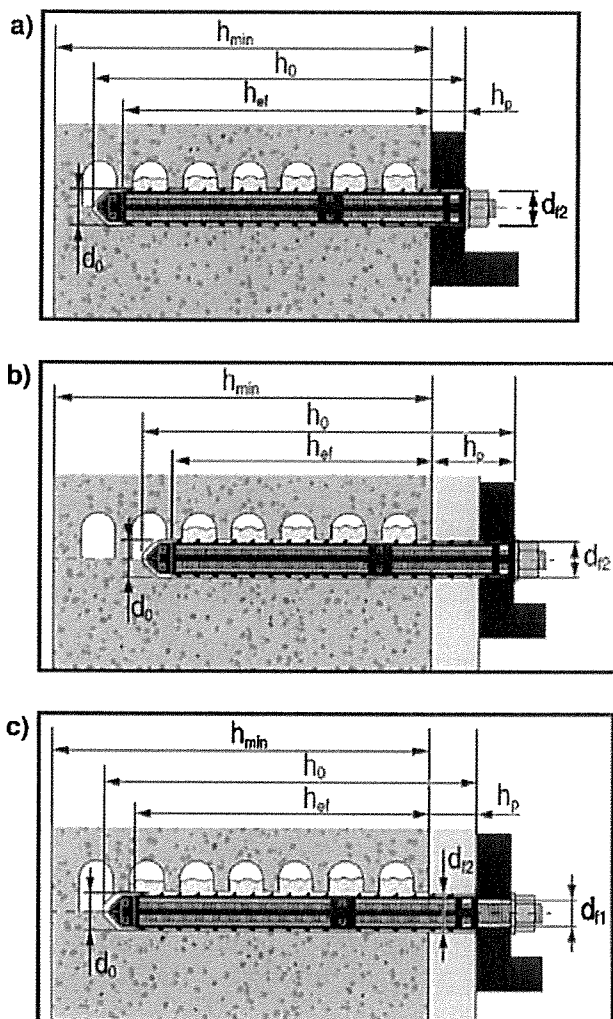

Hilti HIT-HY 270 z HAS-U

Opis wyrobu  
Warunki montażu

Załącznik A2



**Opis wyrobu: Żywica iniekcyjna oraz elementy stalowe**

**Zaprawa iniekcyjna Hilti HIT-HY 270:** system hybrydowy z dodatkiem wypełniacza  
330 ml oraz 500 ml

Oznaczenie  
HILTI HY-270  
Numer produkcyjny oraz  
oznaczenie linii produkcyjnej  
Data przydatności mm/rrrr

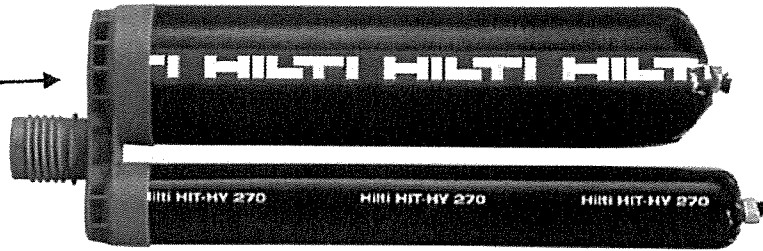

Nazwa wyrobu: "Hilti HIT-HY 270"

**Mieszacz statyczny Hilti HIT-RE-M**



**HAS-U-...**

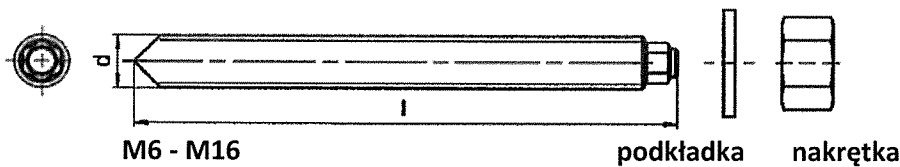

**Tuleja siatkowa HIT-SC 16 to 22**

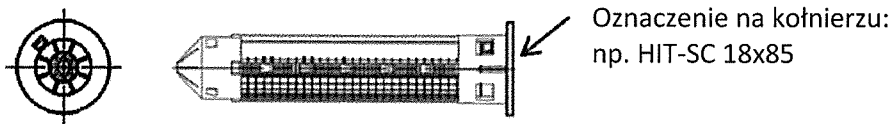

**Hilti HIT-HY 270 z HAS-U**

**Opis wyrobu**

Żywica iniekcyjna / Mieszacz statyczny / Element stalowy / Tuleja siatkowa

Załącznik A3

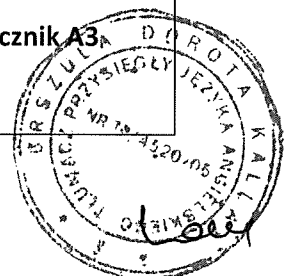



**Tabela A1: Materiały**

Oznaczenie	Materiał
<b>Elementy metalowe ze stali ocynkowanej</b>	
HAS-U-5.8 (HDG)	Klasa wytrzymałości 5.8, $f_{uk} = 500 \text{ N/mm}^2$ ; $f_{yk} = 400 \text{ N/mm}^2$ , Wydłużenie przy zerwaniu ( $l_0 = 5d$ ) > 8% ciągliwości Ocynkowany galwanicznie $\geq 5 \mu\text{m}$ , (HDG) ocynkowany ogniowo $\geq 45 \mu\text{m}$
HAS-U-8.8 (HDG)	Klasa wytrzymałości 8.8, $f_{uk} = 800 \text{ N/mm}^2$ ; $f_{yk} = 640 \text{ N/mm}^2$ , Wydłużenie przy zerwaniu ( $l_0 = 5d$ ) > 12% ciągliwości Ocynkowany galwanicznie $\geq 5 \mu\text{m}$ , (HDG) ocynkowany ogniowo $\geq 45 \mu\text{m}$
Podkładka	Ocynkowana galwanicznie $\geq 5 \mu\text{m}$ Ocynkowana ogniowo $\geq 45 \mu\text{m}$
Nakrętka	Klasa wytrzymałości nakrętki dostosowana do klasy wytrzymałości pręta gwintowanego Ocynkowana galwanicznie $\geq 5 \mu\text{m}$ , ocynkowana ogniowo $\geq 45 \mu\text{m}$
<b>Elementy metalowe ze stali nierdzewnej</b>	
HAS-U A4	Klasa wytrzymałości 70, $f_{uk} = 700 \text{ N/mm}^2$ , $f_{yk} = 450 \text{ N/mm}^2$ . Wydłużenie przy zerwaniu ( $l_0 = 5d$ ) > 8% ciągliwości. Stal nierdzewna A4 zgodnie z EN 10088-1:2014
Podkładka	Stal nierdzewna A4 zgodnie z EN 10088-1:2014
Nakrętka	Klasa wytrzymałości nakrętki dostosowana do klasy wytrzymałości pręta gwintowanego Stal nierdzewna A4 zgodnie z EN 10088-1:2014
<b>Elementy metalowe ze stali o wysokiej odporności na korozję</b>	
HAS-U-HCR	$f_{uk} = 800 \text{ N/mm}^2$ , $f_{yk} = 640 \text{ N/mm}^2$ Wydłużenie przy zerwaniu ( $l_0 = 5d$ ) > 8% ciągliwości. Stal o wysokiej odporności na korozję zgodnie z EN 10088-1:2014
Podkładka	Stal o wysokiej odporności na korozję zgodnie z EN 10088-1:2014
Nakrętka	Klasa wytrzymałości nakrętki dostosowana do klasy wytrzymałości pręta gwintowanego. Stal o wysokiej odporności na korozję zgodnie z EN 10088-1:2014
<b>Elementy z tworzywa sztucznego</b>	
Tuleja siatkowa HIT-SC	Rama: FPP 20T Siatka: PA6.6 N500/200

Hilti HIT-HY 270 z HAS-U

Opis wyrobu  
Materiały

Załącznik A4

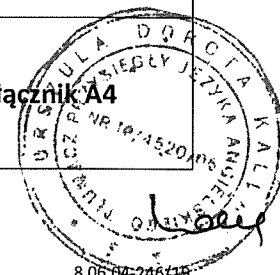

### Szczegóły techniczne zamierzonego stosowania

#### Materiały podłoża:

- Konstrukcja murowa z cegły pełnej (kategoria zastosowania b) według Załącznika B3.  
Uwaga: Nośność charakterystyczna dotyczy także większych cegieł oraz wyższych wytrzymałości na ściskanie elementów murowych.
- Konstrukcja murowa z cegły otworowej (kategoria zastosowania c) według Załącznika B3 oraz B5.
- Klasa wytrzymałości na ściskanie zaprawy dla konstrukcji murowej: co najmniej M2.5 według EN 998-2:2010.
- W przypadku konstrukcji murowych wykonanych z innych cegieł pełnych, otworowych lub perforowanych nośność charakterystyczna kotwy może być wyznaczona na podstawie testów na miejscu montażu według TR 053, kwiecień 2016, z uwzględnieniem współczynnika  $\beta$  podanego w Załączniku C1, Tabela C1.

Tabela B1: Przegląd kategorii zastosowania:

Zakotwienia obejmujące:	HIT-HY 270 z HAS-U	
	W ceglach pełnych	W ceglach otworowych
Wiercenie otworów 	Tryb udarowy, tryb obrotowy	Tryb obrotowy
Obciążenia statyczne i quasi-statyczne	Załącznik: C1 (stal), C3 do C20	Załącznik: C1 (stal), C21 do C30
Kategoria zastosowania: konstrukcja sucha lub mokra	Kategoria <b>d/d - Montaż i zastosowanie</b> w konstrukcjach pracujących w <b>suchych</b> warunkach wewnętrznych. Kategoria <b>w/d - Montaż w suchych lub mokrych podłożach oraz zastosowanie</b> w konstrukcjach pracujących w <b>suchych</b> warunkach wewnętrznych (za wyjątkiem cegieł silikatowych). Kategoria <b>w/w - Montaż i zastosowanie</b> w konstrukcjach pracujących w <b>suchych lub mokrych</b> warunkach środowiskowych (za wyjątkiem cegieł silikatowych).	
Kierunek montażu Konstrukcja murowa	Poziomy	
Kierunek montażu Cegła stropowa	Montaż nad głową	
Kategoria zastosowania	b (konstrukcja murowa z elementów pełnych)	c (konstrukcja murowa z elementów otworowych lub perforowanych)
Temperatura materiału podłoża przy montażu	od +5° C do +40° C (Tabela B9)	od 0° C do +40° C (Tabela B10)
Temperatura eksploatacji	Zakres temperatury Ta:	od -40°C do +40°C (maks. temperatura przy oddziaływaniu długotrwałym +24 °C oraz maks. temperatura przy oddziaływaniu krótkotrwałym +40 °C)
	Zakres temperatury Tb:	od -40°C do +80°C (maks. temperatura przy oddziaływaniu długotrwałym +50 °C oraz maks. temperatura przy oddziaływaniu krótkotrwałym +80°C)

Hilti HIT-HY 270 z HAS-U

Zamierzone zastosowanie  
Specyfikacje

Załącznik B1



#### Warunki użycia (warunki środowiskowe):

- Konstrukcje pracujące w suchych warunkach wewnętrznych (stal cynkowana, stal nierdzewna lub stal o wysokiej odporności na korozję).
- Konstrukcje narażone na czynniki atmosferyczne (włączając środowisko przemysłowe i morskie) oraz ciągłą wilgoć w warunkach wewnętrznych, jeśli nie występują szczególnie agresywne warunki (stal nierdzewna lub stal o wysokiej odporności na korozję).
- Konstrukcje narażone na czynniki atmosferyczne oraz ciągłą wilgoć w warunkach wewnętrznych, jeśli nie występują szczególnie agresywne warunki (stal o wysokiej odporności na korozję).

Uwaga: Do warunków szczególnie agresywnych zalicza się np. ciągłe, zmieniające się zanurzenie w wodzie morskiej lub strefy rozbryzgu wody morskiej, środowisko basenów krytych o znacznej zawartości chlorków lub atmosferę w znacznym stopniu zanieczyszczoną chemicznie (np. instalacje odsiarczania lub tunele drogowe, w których stosowane są substancje odladzające).

#### Projektowanie:

- Zakotwienia powinny być projektowane pod nadzorem inżyniera doświadczonego w zakresie zakotwień oraz robót murarskich.
- Obliczenia sprawdzające i dokumentacja rysunkowa muszą być sporządzane z uwzględnieniem obciążeń, jakie powinny być przeniesione. Położenie kotew powinno być określone na rysunkach projektowych (np. poprzez podanie położenia kotwy względem podpór, itp.).
- Zakotwienia pod obciążenia statyczne lub quasi-statyczne powinny być projektowane zgodnie z: TR 054, kwiecień 2016 Metoda projektowania A.
- W przypadku wytrzymałości cegły na ściskanie  $f_b$  poniżej najwyższej wytrzymałości podanej w tabeli obciążeń, obciążenie można obliczyć korzystając z równania:

$$F_{RK,act.} = F_{RK,ETA,(fb)} * (f_{b,act.}/f_{b,ETA})^\alpha$$

$F_{RK,act.}$  = Nośność łącznika w rzeczywistym elemencie murowym

$F_{RK,ETA,(fb)}$  = Nośność łącznika w elemencie murowym podana w Załączniku C3 do C30

$f_{b,act.}$  = Rzeczywista znormalizowana średnia wytrzymałość na ściskanie elementu murowego według EN 772-1:2011

$f_{b,ETA}$  = znormalizowana średnia wytrzymałość na ściskanie podana w Załączniku C3 do C30

$\alpha$  = 0,5 dla elementów murowych ceramicznych lub betonowych i z cegły pełnej silikatowej

$\alpha$  = 0,75 dla elementów murowych z cegły perforowanej silikatowej

- Dla konstrukcji murowej z cegły otworowej. Obciążenie ścinające działające pionowo na wolną krawędź powinno być przenoszone przez spoinę pionową. (Całkowicie wypełniona spoina lub styk bezpośredni).
- Dla konstrukcji murowej z cegły otworowej dopuszczalne jest wyłącznie obciążenie ścinające bez ramienia dźwigni.

#### Montaż:

- Montaż kotew powinien być wykonywany przez wykwalifikowany personel pod nadzorem osoby odpowiedzialnej za nadzór techniczny budowy.

Hilti HIT-HY 270 z HAS-U



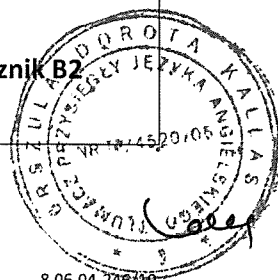

Zamierzone zastosowanie

Specyfikacje

Załącznik B2

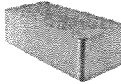
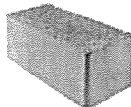
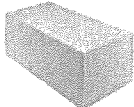

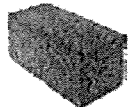
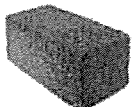
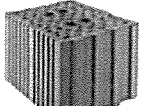
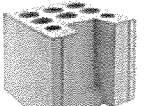
**Tabela B2: Zestawienie typów i właściwości cegieł**

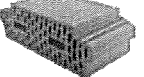
Typ cegły	Ilustracja	Rozmiar cegły [mm]	Wytrzymałość na ściskanie $f_{b,ETA}$ [N/mm <sup>2</sup> ]	Gęstość objętościowa [kg/dm <sup>3</sup> ]	Załącznik
Cegła ceramiczna pełna EN 771-1		≥ 240x115x52	12 / 20 / 40	2,0	C3/C4
Cegła ceramiczna pełna EN 771-1		≥ 240x115x72	10 / 20	2,0	C5/C7
Cegła ceramiczna pełna EN 771-1		≥ 240x115x113	12 / 20	2,0	C8/C10
Cegła silikatowa pełna EN 771-2		≥ 240x115x113	12 / 28	2,0	C11/C12
Cegła silikatowa pełna EN 771-2		≥ 248x240x248	12 / 20 / 28	2,0	C13/C16
Cegła pełna z betonu lekkiego EN 771-3		≥ 240x115x113	4 / 6	0,9	C17/C18
Cegła pełna z betonu zwykłego EN 771-3		≥ 240x115x113	6 / 16	2,0	C19/C20
Cegła ceramiczna otworowa EN 771-1		300x240x238	12 / 20	1,4	C21/C22
Cegła silikatowa otworowa EN 771-2		248x240x248	12 / 20	1,4	C23/C24
Cegła otworowa z betonu lekkiego EN 771-3		495x240x238	2 / 6	0,7	C25/C27
Cegła otworowa z betonu zwykłego EN 771-3		500x200x200	4 / 10	0,9	C28/C29
Cegła ceramiczna otworowa EN 771-1 Cegła stropowa		250x510x180	DIN EN 15037-3 klasa R2	1,0	C30

Hilti HIT-HY 270 z HAS-U







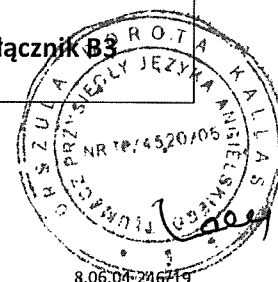



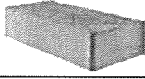
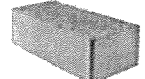

Zamierzone zastosowanie

Typy i właściwości cegieł

Załącznik B3



**Tabela B3: Zestawienie elementów mocujących (wraz z wymiarami i głębokościami osadzenia) oraz odpowiadających typów cegieł**

Typ cegły	Ilustracja	HAS-U 	HAS-U + HIT-SC 	Załącznik
Cegła ceramiczna pełna EN 771-1		M8 do M16 $h_{ef} = 50 \text{ mm do } 300 \text{ mm}$	M8 do M16 $h_{ef} = 80 \text{ mm do } 160 \text{ mm}$	C3/C4
Cegła ceramiczna pełna EN 771-1		M8 do M16 $h_{ef} = 50 \text{ mm do } 300 \text{ mm}$	M8 do M16 $h_{ef} = 80 \text{ mm do } 160 \text{ mm}$	C5/C7
Cegła ceramiczna pełna EN 771-1		M8 do M16 $h_{ef} = 50 \text{ mm do } 300 \text{ mm}$	M8 do M16 $h_{ef} = 80 \text{ mm do } 160 \text{ mm}$	C8/C10
Cegła silikatowa pełna EN 771-2		M8 do M16 $h_{ef} = 50 \text{ mm do } 300 \text{ mm}$	M8 do M16 $h_{ef} = 80 \text{ mm do } 160 \text{ mm}$	C11/C12
Cegła silikatowa pełna EN 771-2		M8 do M16 $h_{ef} = 50 \text{ mm do } 300 \text{ mm}$	M8 do M16 $h_{ef} = 80 \text{ mm do } 160 \text{ mm}$	C13/C16
Cegła pełna z betonu lekkiego EN 771-3		M8 do M16 $h_{ef} = 50 \text{ mm do } 300 \text{ mm}$	M8 do M16 $h_{ef} = 80 \text{ mm do } 160 \text{ mm}$	C17/C18
Cegła pełna z betonu zwykłego EN 771-3		M8 do M16 $h_{ef} = 50 \text{ mm do } 300 \text{ mm}$	M8 do M16 $h_{ef} = 80 \text{ mm do } 160 \text{ mm}$	C19/C20
Cegła ceramiczna otworowa EN 771-1		-	M8 do M16 $h_{ef} = 80 \text{ mm do } 160 \text{ mm}$	C21/C22
Cegła silikatowa otworowa EN 771-2		-	M8 do M16 $h_{ef} = 80 \text{ mm do } 160 \text{ mm}$	C23/C24
Cegła otworowa z betonu lekkiego EN 771-3		-	M8 do M16 $h_{ef} = 80 \text{ mm do } 160 \text{ mm}$	C25/C27
Cegła otworowa z betonu zwykłego EN 771-3		-	M8 do M16 $h_{ef} = 50 \text{ mm do } 160 \text{ mm}$	C28/C29
Cegła ceramiczna otworowa EN 771-1 Cegła stropowa		-	M6 $h_{ef} = 80 \text{ mm}$	C30

Hilti HIT-HY 270 z HAS-U

Zamierzone zastosowanie

Elementy mocujące oraz odpowiadające typy cegieł

Załącznik B4

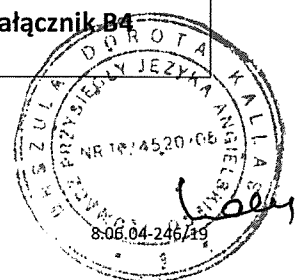

**Tabela B4: Parametry cegieł otworowych**

Cegła ceramiczna  
otworowa  
EN 771-1

Rapis Ziegel Hlz 12-1,4-  
10DF

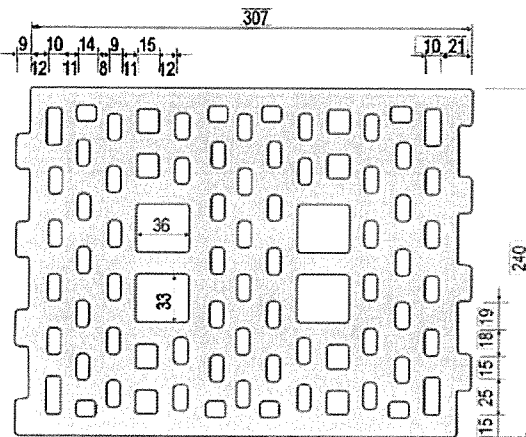
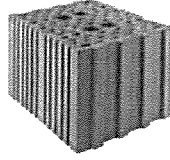

Cegła silikatowa otworowa  
EN 771-2

KS Wemding  
KSL-R(P) 12-1,4 8DF

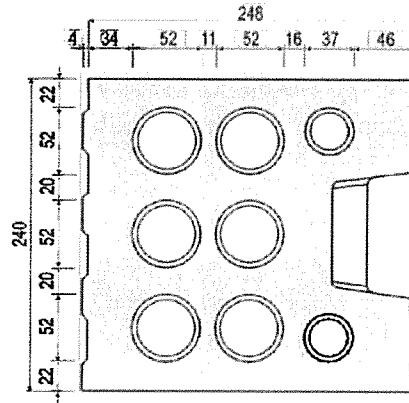
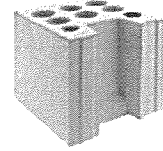

Cegła otworowa  
z betonu zwykłego  
EN 771-3

Parpaing creux  
B40

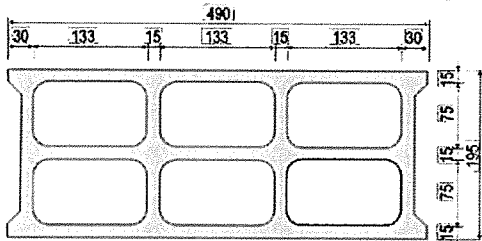
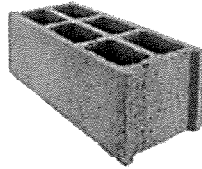

Cegła otworowa z betonu  
lekkiego  
EN 771-3

Knobel Betonwerk  
Hbl 4-0,8-500x240x238

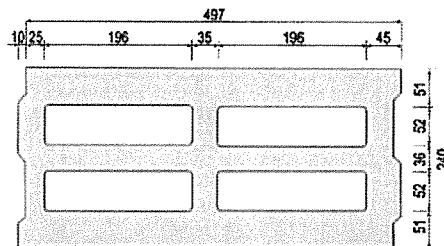
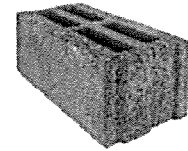

Cegła ceramiczna  
otworowa  
EN 771-1

Cegła stropowa  
Fiedler Brick Ceiling  
Typ 18+0 lub 18+3

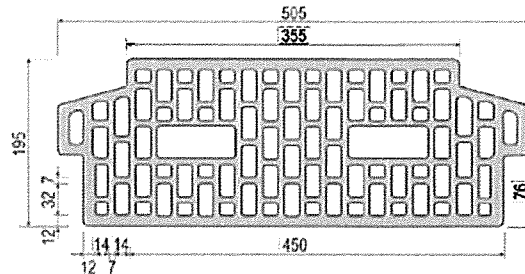
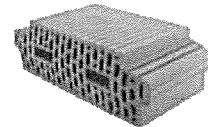

Hilti HIT-HY 270 z HAS-U

Zamierzone zastosowanie

Parametry cegieł otworowych

Załącznik B5

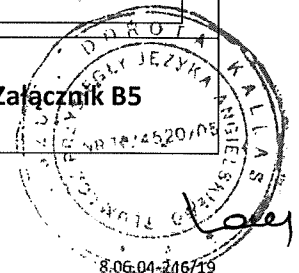

**Tabela B5: Parametry montażowe HAS-U-... z jedną tuleją siatkową HIT-SC w cegle otworowej i cegle pełnej (rys. A1)**

HAS-U-...		M6	M8		M10		M12		M16	
z HIT-SC		12x85	16x50	16x85	16x50	16x85	18x50	18x85	22x50	22x85
Nominalna średnica wiertła	$d_0$ [mm]	12	16	16	16	16	18	18	22	22
Głębokość wierconego otworu	$h_0$ [mm]	95	60	95	60	95	60	95	60	95
Efektywna głębokość osadzenia	$h_{ef}$ [mm]	80	50	80	50	80	50	80	50	80
Maksymalna średnica otworu przelotowego w elemencie mocowanym	$d_f$ [mm]	7	9	9	12	12	14	14	18	18
Minimalna grubość ściany	$h_{min}$ [mm]	115	80	115	80	115	80	115	80	115
Szczotka HIT-RB	- [-]	12	16	16	16	16	18	18	22	22
Liczba naciśnień spustu dozownika HDM	- [-]	5	4	6	4	6	4	8	6	10
Liczba naciśnień spustu dozownika HDE 500-A	- [-]	4	3	5	3	5	3	6	5	8
Maksymalny moment dokręcający dla wszystkich typów cegieł poza „parpaing creux”	$T_{max}$ [Nm]	0	3	3	4	4	6	6	8	8
Maks. moment dokręcający dla „parpaing creux”	$T_{max}$ [Nm]	-	2	2	2	2	3	3	6	6

**Tabela B6: Parametry montażowe HAS-U-... z dwoma tulejami siatkowymi HIT-SC w cegle otworowej i cegle pełnej dla większych głębokości osadzenia (rys. A2)**

HAS-U-...		M8		M10	
z HIT-SC		16x50+16x85	16x85+16x85	16x50+16x85	16x85+16x85
Nominalna średnica wiertła	$d_0$ [mm]	16		16	
Głębokość wierconego otworu	$h_0$ [mm]	145		180	
Efektywna głębokość osadzenia	$h_{ef}$ [mm]	130		160	
Maksymalna średnica otworu przelotowego w elemencie mocowanym	$d_f$ [mm]	9		12	
Minimalna grubość ściany	$h_{min}$ [mm]	195		230	
Szczotka HIT-RB	- [-]	16		16	
Liczba naciśnień spustu dozownika HDM	- [-]	4+6		6+6	
Liczba naciśnień spustu dozownika HDE-500	- [-]	3+5		5+5	
Maks. moment dokręcający	$T_{max}$ [Nm]	3		4	

**Tabela B6 ciąg dalszy**

HAS-U-...		M12		M16	
z HIT-SC		18x50+18x85	18x85+18x85	22x50+22x85	22x85+22x85
Nominalna średnica wiertła	$d_0$ [mm]	18		22	
Głębokość wierconego otworu	$h_0$ [mm]	145		180	
Efektywna głębokość osadzenia	$h_{ef}$ [mm]	130		160	
Maksymalna średnica otworu przelotowego w elemencie mocowanym	$d_f$ [mm]	14		18	
Minimalna grubość ściany	$h_{min}$ [mm]	195		230	
Szczotka HIT-RB	- [-]	18		22	
Liczba naciśnień spustu dozownika HDM	- [-]	4+8		6+10	
Liczba naciśnień spustu dozownika HDE-500	- [-]	3+6		5+8	
Maksymalny moment dokręcający	$T_{max}$ [Nm]	6		8	

Hilti HIT-HY 270 z HAS-U

Zamierzone zastosowanie

Parametry montażowe

Załącznik B6

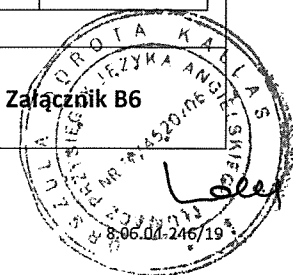

**Tabela B7: Parametry montażowe HAS-U-... w cegle pełnej (rys. A3)**

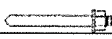
HAS-U-...		M8	M10	M12	M16
Nominalna średnica wiertła	$d_0$ [mm]	10	12	14	18
Głębokość wierconego otworu = Efektywna głębokość osadzenia	$h_0 = h_{ef}$ [mm]	50...300	50...300	50...300	50...300
Maksymalna średnica otworu przelotowego w elemencie mocowanym	$d_f$ [mm]	9	12	14	18
Minimalna grubość ściany	$h_{min}$ [mm]	$h_0+30$	$h_0+30$	$h_0+30$	$h_0+36$
Szczotka HIT-RB	- [-]	10	12	14	18
Maksymalny moment dokręcający	$T_{max}$ [Nm]	5	8	10	10

Hilti HIT-HY 270 z HAS-U

Zamierzone zastosowanie  
Parametry montażowe

Załącznik B7





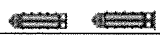

**Tabela B8: Parametry montażowe HAS-U-... z dwoma tulejami siatkowymi HIT-SC do zakotwienia przez element mocowany i/lub przez warstwę nienośną w cegle otworowej i cegle pełnej (rys. A4)**

HAS-U-...		M8		M10	
<b>z HIT-SC</b>		<b>16x50+16x85</b>	<b>16x85+16x85</b>	<b>16x50+16x85</b>	<b>16x85+16x85</b>
Nominalna średnica wiertła	$d_0$ [mm]	16	16	16	16
Głębokość wierconego otworu	$h_0$ [mm]	145	180	145	180
Min. efektywna głębokość osadzenia	$h_{ef,min}$ [mm]	80	80	80	80
Maks. grubość warstwy nienośnej oraz elementu mocowanego (montaż przelotowy)	$h_{p,max}$ [mm]	50	80	50	80
Maks. średnica otworu przelotowego w elemencie mocowanym (montaż wstępny)	$d_{f1}$ [mm]	9	9	12	12
Maks. średnica otworu przelotowego w elemencie mocowanym (montaż przelotowy)	$d_{f2}$ [mm]	17	17	17	17
Min. grubość ściany	$h_{min}$ [mm]	$h_{ef}+65$	$h_{ef}+70$	$h_{ef}+65$	$h_{ef}+70$
Szczotka HIT-RB	- [-]	16	16	16	16
Liczba naciśnień spustu dozownika HDM	- [-]	4+6	6+6	4+6	6+6
Liczba naciśnień spustu dozownika HDE-500	- [-]	3+5	5+5	3+5	5+5
Maksymalny moment dokręcający dla wszystkich typów cegieł poza „parpaing creux”	$T_{max}$ [Nm]	3	3	4	4
Maksymalny moment dokręcający dla „parpaing creux”	$T_{max}$ [Nm]	2	2	2	2

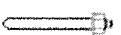
**Tabela B8 ciąg dalszy**

HAS-U-...		M12		M16	
<b>z HIT-SC</b>		<b>18x50+18x85</b>	<b>18x85+18x85</b>	<b>22x50+22x85</b>	<b>22x85+22x85</b>
Nominalna średnica wiertła	$d_0$ [mm]	18	18	22	22
Głębokość wierconego otworu	$h_0$ [mm]	145	180	145	180
Min. efektywna głębokość osadzenia	$h_{ef,min}$ [mm]	80	80	80	80
Maks. grubość warstwy nienośnej oraz elementu mocowanego (montaż przelotowy)	$h_{p,max}$ [mm]	50	80	50	80
Maks. średnica otworu przelotowego w elemencie mocowanym (montaż wstępny)	$d_{f1}$ [mm]	14	14	18	18
Maks. średnica otworu przelotowego w elemencie mocowanym (montaż przelotowy)	$d_{f2}$ [mm]	19	19	23	23
Min. grubość ściany	$h_{min}$ [mm]	$h_{ef}+65$	$h_{ef}+70$	$h_{ef}+65$	$h_{ef}+70$
Szczotka HIT-RB	- [-]	18	18	22	22
Liczba naciśnień spustu dozownika HDM	- [-]	4+8	8+8	6+10	10+10
Liczba naciśnień spustu dozownika HDE-500	- [-]	5+8	8+8	5+8	8+8
Maksymalny moment dokręcający dla wszystkich typów cegieł poza „parpaing creux”	$T_{max}$ [Nm]	6	6	8	8
Maksymalny moment dokręcający dla „parpaing creux”	$T_{max}$ [Nm]	3	3	6	6

Hilti HIT-HY 270 z HAS-U

Zamierzone zastosowanie  
Parametry montażowe

Załącznik B8



**Tabela B9: Maksymalny czas roboczy oraz minimalny czas utwardzania dla cegieł pełnych<sup>1)</sup>**

Temperatura materiału podłoża T	Maksymalny czas roboczy $t_{work}$	minimalny czas utwardzania $t_{cure}$
od 5 °C do 9 °C	10 min	2,5 h
od 10 °C do 19 °C	7 min	1,5 h
od 20 °C do 29 °C	4 min	30 min
od 30 °C do 40 °C	1 min	20 min

<sup>1)</sup> Podane czasy utwardzania obowiązują wyłącznie dla suchego materiału podłoża.

W przypadku mokrego materiału podłoża, czasy utwardzania należy podwoić.

**Tabela B10: Maksymalny czas roboczy oraz minimalny czas utwardzania dla cegieł otworowych<sup>1)</sup>**

Temperatura materiału podłoża T	Maksymalny czas roboczy $t_{work}$	minimalny czas utwardzania $t_{cure}$
od 0 °C do 4 °C	10 min	4 h
od 5 °C do 9 °C	10 min	2,5 h
od 10 °C do 19 °C	7 min	1,5 h
od 20 °C do 29 °C	4 min	30 min
od 30 °C do 40 °C	1 min	20 min

<sup>1)</sup> Podane czasy utwardzania obowiązują wyłącznie dla suchego materiału podłoża.

W przypadku mokrego materiału podłoża, czasy utwardzania należy podwoić.

**Tabela B11: Metody czyszczenia otworów**

**Czyszczenie ręczne (MC):**

Pompka ręczna Hilti do przedmuchiwania wierconych otworów o średnicy  $d_0 \leq 18$  mm oraz maks. głębokości  $h_0 = 100$  mm.



**Czyszczenie sprężonym powietrzem (CAC):**

Dysza do sprężonego powietrza z otworem wylotowym o średnicy co najmniej 3,5 mm do przedmuchiwania wierconych otworów o maks. głębokości  $h_0 = 300$  mm.

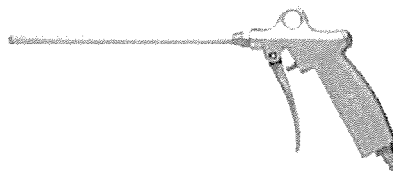

**Szczotka stalowa HIT-RB:**

według Tabeli B5 do B8, w zależności od średnicy otworu do czyszczenia ręcznego lub sprężonym powietrzem.



Hilti HIT-HY 270 z HAS-U

Zamierzone zastosowanie

Parametry montażowe

Narzędzia do czyszczenia

Załącznik B9

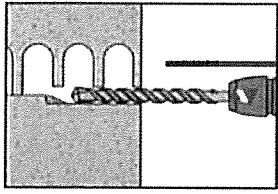
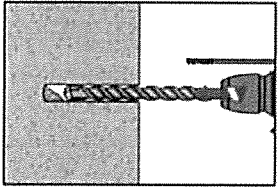
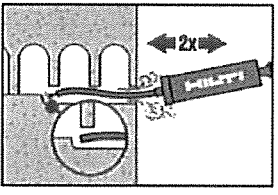
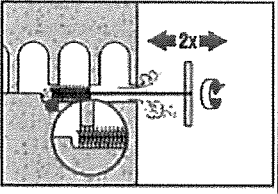
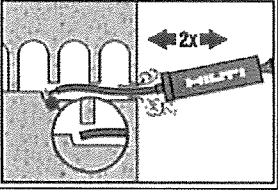

<b>Montaż</b>	
<b>Wiercenie otworów</b>	Jeśli podczas wiercenia otworu na całej głębokości nie jest wyczuwalny opór (np. niewypełnione połączenia na styk), nie należy osadzać kotwy w wykonanym otworze.
<b>Tryb wiercenia</b>	
	<b>Cegły otworowe i pełne (kategoria zastosowania c): tryb obrotowy</b> Wywiercić otwór o wymaganej głębokości osadzania wiertarką udarową w trybie obrotowym z użyciem odpowiedniego rozmiaru wiertła z końcówką z węglików spiekanych.
	<b>Cegły pełne (kategoria zastosowania b): tryb udarowy</b> Wywiercić otwór o wymaganej głębokości osadzania wiertarką udarową w trybie udarowym z użyciem odpowiedniego rozmiaru wiertła z końcówką z węglików spiekanych.
<b>Czyszczenie otworów</b>	Przed osadzeniem kotwy należy oczyścić otwór z pyłu i zwiercin. Niewłaściwe oczyszczenie otworu = słaba wytrzymałość połączenia.
<b>Czyszczenie ręczne (MC): Cegły otworowe i pełne</b>	
	Pompka ręczna Hilti może być stosowana do przedmuchiwania wierconych otworów o maks. średnicy $d_0 \leq 18$ mm oraz maks. głębokości $h_0 = 100$ mm. Przedmuchać co najmniej dwukrotnie od dna otworu aż do momentu, gdy wylatujący strumień powietrza nie zawiera widocznego pyłu.
	Następnie należy dwukrotnie wyszczotkować otwór przy użyciu stalowej szczotki Hilti HIT-RB o określonym rozmiarze (patrz Tabela B5 do B8) poprzez jej wprowadzenie ruchem okrężnym do dna otworu (jeśli to konieczne, stosując przedłużkę) i wyciągnięcie. Szczotka powinna napotykać opór podczas wkładania do otworu ( $\varnothing$ szczotki $\geq \varnothing$ otworu) - szczotkę o zbyt małej średnicy należy wymienić na szczotkę o odpowiedniej średnicy.
	Przedmuchać ponownie pompką ręczną Hilti co najmniej dwukrotnie do momentu, gdy wylatujący strumień powietrza nie zawiera widocznego pyłu.
<b>Hilti HIT-HY 270 z HAS-U</b>	
<b>Zamierzone zastosowanie</b> Instrukcja montażu	<b>Załącznik B10</b>

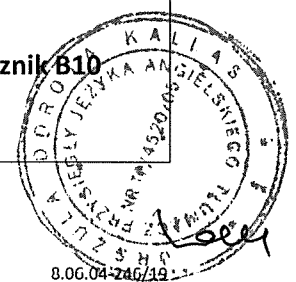

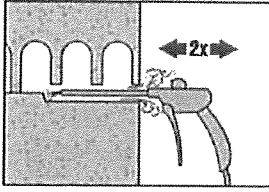
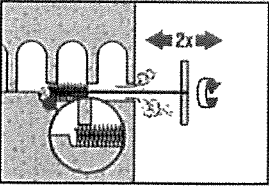
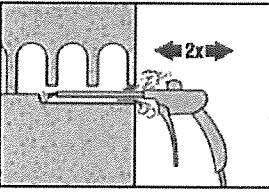
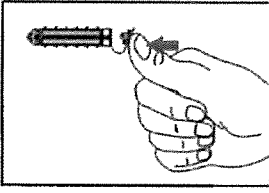
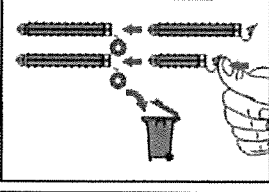
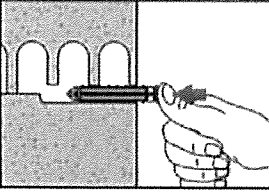
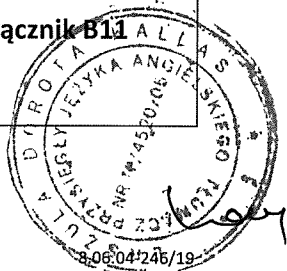
<b>Czyszczenie sprężonym powietrzem (CAC): Cegły otworowe i pełne</b>	
	Przedmuchać dwukrotnie od dna otworu (jeśli to konieczne, użyć przedłużki dyszy) na całej długości przy użyciu niezaolejonego sprężonego powietrza (ciśnienie min. 6 bar przy wydajności 6 m³/h; maks. głębokość wierzonych otworów h <sub>0</sub> = 300 mm) aż do momentu, gdy wylatujący strumień powietrza nie zawiera widocznego pyłu.
	Następnie należy dwukrotnie wyszczotkować otwór przy użyciu stalowej szczotki Hilti HIT-RB o określonym rozmiarze (patrz Tabela B5 do B8) poprzez jej wprowadzenie ruchem okrężnym do dna otworu (jeśli to konieczne, stosując przedłużkę) i wyciągnięcie. Szczotka powinna napotykać opór podczas wkładania do otworu (∅ szczotki ≥ ∅ otworu) - szczotkę o zbyt małej średnicy należy wymienić na szczotkę o odpowiedniej średnicy.
	Przedmuchać ponownie dwukrotnie pompką ręczną Hilti lub sprężonym powietrzem aż do momentu, gdy wylatujący strumień powietrza nie zawiera widocznego pyłu.
<b>Przygotowanie iniekcji żywicy w konstrukcji murewej z otworami lub pustymi przestrzeniami: montaż z tuleją siatkową HIT-SC</b>	
	<b>Pojedyncza tuleja siatkowa HIT-SC</b> Zamknąć kołnierz tulei.
	<b>Dwie tuleje siatkowe HIT-SC</b> Połączyć obie tuleje siatkowe. Wyrzucić niewykorzystaną nasadkę. Zachować wymaganą kolejność tulei siatkowych w przypadku użycia tulei siatkowych o różnej długości: krótsza tuleja siatkowa powinna być wkładana do dłuższej.
	Ręcznie włożyć tuleję siatkową. W przypadku użycia dwóch tulei siatkowych, dłuższą tuleję siatkową należy włożyć jako pierwszą.
<b>Hilti HIT-HY 270 z HAS-U</b>	
<b>Zamierzone zastosowanie</b> Instrukcja montażu	<b>Załącznik B11</b> 

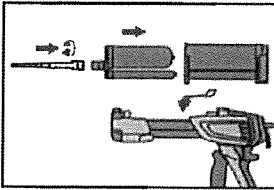
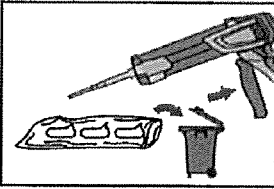
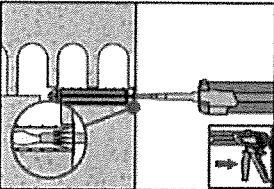
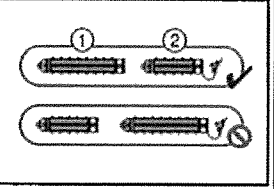
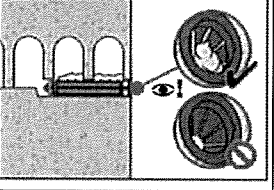
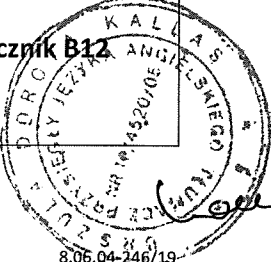
<b>Wszystkie zastosowania</b>					
	<p>Należy dokładnie zamocować mieszacz statyczny Hilti HIT-RE-M do końcówki ładunku foliowego.</p> <p>Nie należy wprowadzać jakichkolwiek zmian w mieszaczu.</p> <p>Przestrzegać instrukcji obsługi dozownika oraz ładunku foliowego.</p> <p>Sprawdzić, czy kasetka ładunku foliowego działa prawidłowo. Nie stosować uszkodzonych opakowań foliowych i kaset. Należy wprowadzić ładunek foliowy do kasetki oraz umieścić kasetkę w dozowniku HIT.</p>				
	<p>Nie stosować początkowej porcji żywicy. Ładunek foliowy otwiera się automatycznie po rozpoczęciu dozowania. W zależności od objętości ładunku foliowego, należy odrzucić początkową porcję żywicy. Objętości, które należy odrzucić:</p> <table border="0"> <tr> <td>2 naciśnięcia spustu dozownika</td> <td>dla ładunku foliowego 330 ml,</td> </tr> <tr> <td>3 naciśnięcia spustu dozownika</td> <td>dla ładunku foliowego 500 ml.</td> </tr> </table>	2 naciśnięcia spustu dozownika	dla ładunku foliowego 330 ml,	3 naciśnięcia spustu dozownika	dla ładunku foliowego 500 ml.
2 naciśnięcia spustu dozownika	dla ładunku foliowego 330 ml,				
3 naciśnięcia spustu dozownika	dla ładunku foliowego 500 ml.				
<b>Dozować żywicę unikając tworzenia się pęcherzyków powietrza</b>					
<b>Montaż z tuleją siatkową HIT-SC</b>					
	<p><b>Pojedyncza tuleja siatkowa HIT-SC</b></p> <p>Wsunąć mieszacz statyczny na głębokość około 1 cm przez nasadkę. Wprowadzić wymaganą ilość żywicy (patrz Tabela B5 do B8). Żywica powinna wypłynąć przez nasadkę.</p>				
	<p><b>Dwie tuleje siatkowe HIT-SC</b></p> <p>Użyć przedłużki do montażu dwóch tulei siatkowych.</p> <p>Wprowadzić mieszacz statyczny na głębokość około 1 cm przez końcówkę tulei siatkowej "2" oraz dozować wymaganą ilość żywicy do tulei siatkowej "1" (patrz Tabela B5 do B8). Wysunąć mieszacz statyczny do momentu, w którym jest wprowadzony na głębokość około 1 cm przez nasadkę do tulei siatkowej "2". Kontynuować iniekcję żywicy do tulei siatkowej "2" zgodnie z opisem powyżej.</p>				
	<p>Kontrolować ilość dozowanej żywicy. Żywica powinna wystawać poza nasadkę.</p> <p>Po zakończeniu iniekcji należy zwolnić nacisk tłoka dozownika poprzez naciśnięcie spustu dźwigni. Zapobiegnie to dalszemu wypływowi żywicy z mieszacza.</p>				
<b>Hilti HIT-HY 270 z HAS-U</b>					
<b>Zamierzone zastosowanie</b> Instrukcja montażu	<p><b>Załącznik B12</b></p> 				

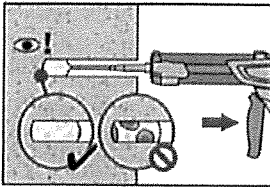
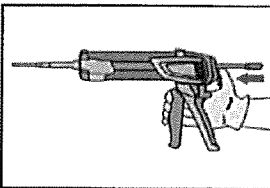
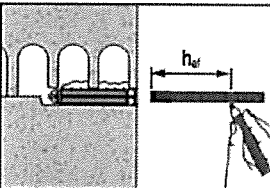
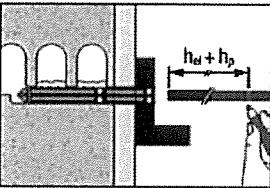
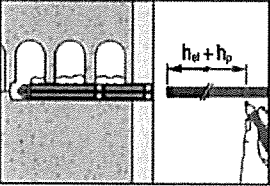
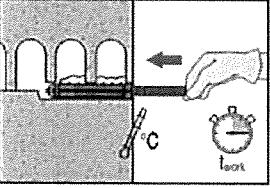
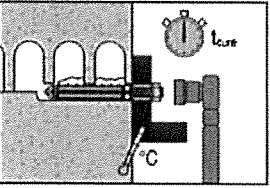
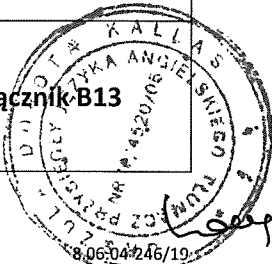
<b>Cegły pełne: montaż bez tulei siatkowej</b>	
	Należy dozować żywicę rozpoczynając od dna otworu, powoli wycofując mieszacz po każdym naciśnięciu spustu dozownika. Wypełnić około 2/3 otworu w celu zapewnienia całkowitego wypełnienia żywicą przestrzeni pierścieniowej między kotwą a materiałem podłoża na całej długości osadzenia.
	Po zakończeniu iniekcji należy zwolnić nacisk tłoka dozownika poprzez naciśnięcie spustu dźwigni. Zapobiegnie to dalszemu wypływowi żywicy z mieszacza.
<b>Osadzanie elementu:</b>	Przed zastosowaniem należy upewnić się, że pręt jest suchy i wolny od oleju lub innych zanieczyszczeń.
	<b>HAS-U-... w ceglach otworowych i pełnych: Wstępne osadzanie (rys. A1 do A4)</b> Oznaczyć pręt na wymaganą głębokość osadzenia $h_{ef}$ zgodnie z Tabelą B5 do B7.
	<b>HAS-U-... w ceglach otworowych i pełnych: zakotwienie przez element mocowany (rys. A4a) lub przez warstwę nienośną i element mocowany (rys. A4b)</b> Oznaczyć pręt na wymaganą głębokość osadzenia $h_{ef} + h_p$ zgodnie z Tabelą B8.
	<b>HAS-U-... w ceglach otworowych i pełnych: zakotwienie przez warstwę nienośną (rys. A4c)</b> Oznaczyć pręt na wymaganą głębokość osadzenia $h_{ef} + h_p$ zgodnie z Tabelą B8.
	Osadzić pręt na wymaganą głębokość do momentu upływu czasu roboczego $t_{work}$ . Czas roboczy $t_{work}$ jest podany w Tabeli B9 oraz B10.
<b>Obciążenie kotwy</b>	
	Kotwa może być obciążona po upływie wymaganego czasu utwardzania $t_{cure}$ (patrz Tabela B9 oraz B10). Stosowany montażowy moment dokręcający nie może przekraczać wartości $T_{max}$ podanych w Tabeli B5 do B8.
<b>Hilti HIT-HY 270 z HAS-U</b>	<b>Załącznik B13</b> 
<b>Zamierzone zastosowanie</b> Instrukcja montażu	

**Tabela C1: Współczynnik  $\beta$  dla testów na miejscu montażu pod obciążeniem rozciągającym**

Kategorie zastosowania		w/w oraz w/d		d/d	
Zakres temperatury		Ta*	Tb*	Ta*	Tb*
Materiał podłoża	Czyszczenie				
Cegła ceramiczna pełna EN 771-1	CAC	0,96	0,96	0,96	0,96
	MC	0,84	0,84	0,84	0,84
Cegła silikatowa pełna EN 771-2	CAC/MC	-	-	0,96	0,80
Cegła pełna z betonu lekkiego EN 771-3	CAC	0,82	0,68	0,96	0,80
	MC	0,81	0,67	0,90	0,75
Cegła pełna z betonu zwykłego EN 771-3	CAC/MC	0,96	0,80	0,96	0,80
Cegła ceramiczna otworowa EN 771-1	CAC	0,96	0,96	0,96	0,96
	MC	0,84	0,84	0,84	0,84
Cegła silikatowa otworowa EN 771-2	CAC/MC	-	-	0,96	0,80
Cegła otworowa z betonu lekkiego EN 771-3	CAC	0,69	0,57	0,81	0,67
	MC	0,68	0,56	0,76	0,63
Cegła otworowa z betonu zwykłego EN 771-3	CAC/MC	0,96	0,80	0,96	0,80

\*Zakres temperatury Ta / Tb patrz Załącznik B1

**Tabela C2: Wartości charakterystyczne nośności stali dla HAS-U przy obciążeniu rozciągającym i ścinającym w konstrukcji murewej**

Zniszczenie stali przy obciążeniu rozciągającym	M6	M8	M10	M12	M16
Nośność charakterystyczna stali $N_{Rk,s}$ [kN]	$A_s \cdot f_{uk}$				
Zniszczenie stali przy obciążeniu ścinającym bez ramienia dźwigni					
Nośność charakterystyczna stali $V_{Rk,s}$ [kN]	$0,5 \cdot A_s \cdot f_{uk}$				
Zniszczenie stali przy obciążeniu ścinającym z ramieniem dźwigni					
Charakterystyczny moment zginający $M_{Rk,s}$ [Nm]	$1,2 \cdot W_{el} \cdot f_{uk}$				

**Hilti HIT-HY 270 z HAS-U**

**Właściwości użytkowe**

Wartości współczynnika  $\beta$  dla testów na miejscu montażu przy obciążeniu rozciągającym.

Nośności charakterystyczne przy obciążeniu rozciągającym oraz ścinającym - zniszczenie stali.

Załącznik C1

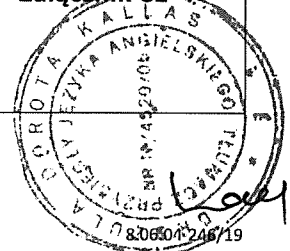

Rozstaw w zależności od odległości od krawędzi dla wszystkich kombinacji kotew:

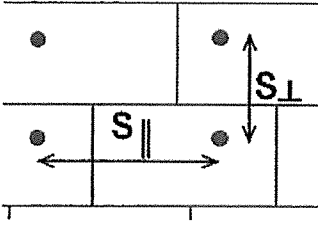
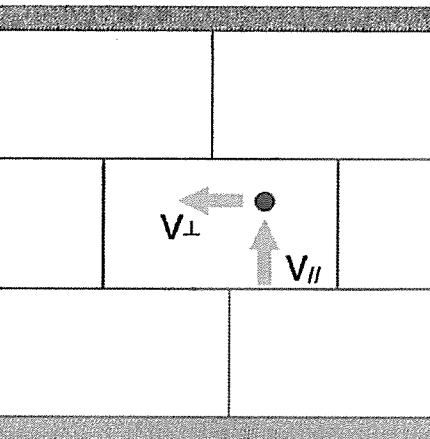
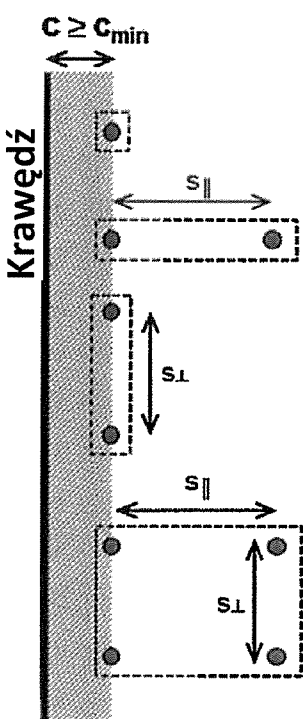
<p>Rozstaw</p>  <p>Kierunek obciążenia ścinającego</p>  <p>Ścinanie II (równoległe do wolnej krawędzi) Ścinanie I (prostopadle do wolnej krawędzi)</p>	<p>Rozstaw</p>  <p><math>S_{\parallel} \geq S_{\min \parallel}</math></p> <p><math>S_{\perp} \geq S_{\min \perp}</math></p> <p><math>S_{\parallel} \geq S_{\min \parallel}</math></p> <p><math>S_{\perp} \geq S_{\min \perp}</math></p>
---	--

Wartości charakterystyczne nośności grupy kotew są obliczane z użyciem współczynników grupowych  $\alpha_g$  według Załącznika C3 do C30:

Grupa dwóch kotew:  $N_{Rk}^g = \alpha_{g,N} \cdot N_{Rk}$  i  $V_{Rk}^g = \alpha_{g,V} \cdot V_{Rk}$  (dla odpowiedniego współczynnika  $\alpha_g$ )

Grupa czterech kotew:  $N_{Rk}^g = \alpha_{g,N \parallel} \cdot \alpha_{g,N \perp} \cdot N_{Rk}$  i  $V_{Rk}^g = \alpha_{g,V \parallel} \cdot \alpha_{g,V \perp} \cdot V_{Rk}$

Hilti HIT-HY 270 z HAS-U

Właściwości użytkowe

Rozstaw kotew

Kierunek obciążenia ścinającego

Załącznik C2

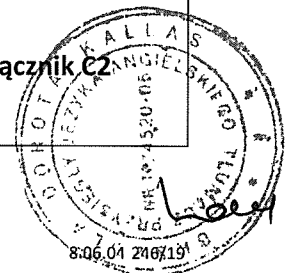



**Typ cegły: Cegła ceramiczna pełna Mz, 1DF**

**Tabela C3: Opis cegły**

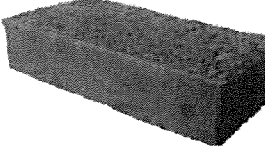
Typ cegły			Pełna Mz, 1DF	
Gęstość objętościowa	$\rho$	[kg/dm <sup>3</sup> ]	2,0	
Wytrzymałość na ściskanie	$f_b$	[N/mm <sup>2</sup> ]	$\geq 12, \geq 20$ lub $\geq 40$	
Norma			EN 771 - 1	
Producent				
Wymiary cegły			[mm] $\geq 240 \times 115 \times 52$	
Minimalna grubość ściany	$h_{min}$	[mm]	$\geq 115$	





**Nośności charakterystyczne dla wszystkich kombinacji kotew (patrz Tabela B3)**

**Tabela C4: Nośność na rozciąganie przy odległości od krawędzi  $c \geq 115$  mm**

Kategoria zastosowania			w/w = w/d		d/d	
Zakres temperatury pracy			Ta	Tb	Ta	Tb
Typ i rozmiar kotwy	$h_{ef}$ [mm]	$f_b$ [N/mm <sup>2</sup> ]	$N_{Rk,p} = N_{Rk,b}$ [kN]			
Wszystkie kotwy	$\geq 50$	12	1,5 (2,0*)			
		20	2,0 (2,5*)			
		40	3,5 (4,0*)			
	$\geq 80$	12	2,5 (3,0*)			
		20	3,5 (4,0*)			
		40	5,5 (6,5*)			
	$\geq 100$	12	3,5 (4,0*)			
		20	4,5 (5,0*)			
		40	7,0 (8,0*)			

\* Tylko czyszczenie sprężonym powietrzem (CAC)

**Odpowiednia odległość od krawędzi, rozstaw oraz współczynnik grupowy  $\alpha_g$**

Konfiguracja	$c \geq$ [mm]	$S_{\perp} \geq$ [mm]	$\alpha_g$ [-]	Konfiguracja	$c \geq$ [mm]	$s_{II} \geq$ [mm]	$\alpha_g$ [-]
	115	-	-	-	-	-	-
	115	55	1,0		115	75	1,35
	115	115	2,0		115	3 $h_{ef}$	2,0

**Hilti HIT-HY 270 z HAS-U**

**Właściwości użytkowe cegły ceramicznej pełnej Mz, 1DF**

Wartości charakterystyczne nośności przy obciążeniu rozciągającym oraz współczynnik grupowy

Załącznik C3

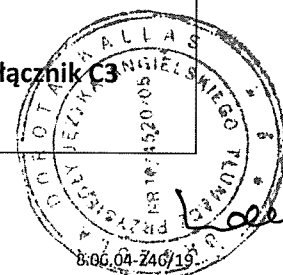

**Tabela C5: Nośność na ścinanie przy odległości od krawędzi  $c \geq 115$  mm (dla  $V_{II}$ ) oraz  $c \geq 1,5 h_{ef}$  (for  $V_{\perp}$ )**

Typ i rozmiar kotwy	$h_{ef}$ [mm]	$f_b$ [N/mm <sup>2</sup> ]	$V_{Rk,b} = V_{Rk,c,II}$ [kN]	$V_{Rk,c,I}$
HAS-U M8; M10	$\geq 50$	12	2,5	Obliczyć według TR 054, równanie 10
		20	3,0	
		40	4,0	
HAS-U M12; M16	$\geq 50$	12	3,5	
		20	4,5	
		40	5,5	
HAS-U M8; M10	$\geq 80$	12	5,0	
		20	6,0	
		40	7,5	
HAS-U M12; M16	$\geq 80$	12	6,5	
		20	8,5	
		40	10,5	

Odpowiednia odległość od krawędzi, rozstaw oraz współczynnik grupowy  $\alpha_g$

Konfiguracja	$c \geq$ [mm]	$s_{\perp} \geq$ [mm]	$\alpha_g$ [-]	Konfiguracja	$c \geq$ [mm]	$s_{\perp} \geq$ [mm]	$\alpha_g$ [-]
	115	-	-		1,5 $h_{ef}$	-	-
	115	55	1,0		1,5 $h_{ef}$	55	1,0
	115	115	2,0		1,5 $h_{ef}$	3 $h_{ef}$	2,0
Konfiguracja	$c \geq$ [mm]	$s_{  }$ [mm]	$\alpha_g$ [-]	Konfiguracja	$c \geq$ [mm]	$s_{  }$ [mm]	$\alpha_g$ [-]
-	-	-	-		1,5 $h_{ef}$	115	1,0
	115	75	2,0		1,5 $h_{ef}$	3 $h_{ef}$	2,0

**Tabela C6: Przemieszczenia**

$h_{ef}$	<b>N</b>	$\delta_{N0}$	$\delta_{N\infty}$	<b>V</b>	$\delta_{V0}$	$\delta_{V\infty}$
[mm]	[kN]	[mm]	[mm]	[kN]	[mm]	[mm]
50	1,2	0,1	0,2	1,4	0,5	0,75
80	2,1	0,1	0,2	2,1	1,1	1,65
100	3,9	0,2	0,4	3,0	1,3	1,95

Hilti HIT-HY 270 z HAS-U

Właściwości użytkowe cegły ceramicznej pełnej Mz, 1DF

Wartości charakterystyczne nośności przy obciążeniu ścinającym oraz współczynnik grupowy  
Przemieszczenia

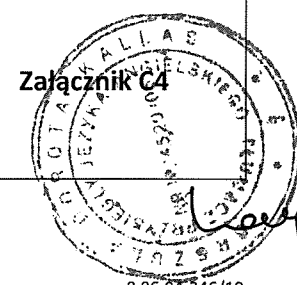

**Typ cegły: Cegła ceramiczna pełna Mz, NF**

**Tabela C7: Opis cegły**

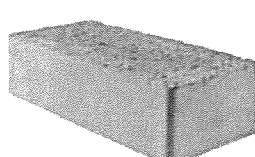
Typ cegły		Pełna Mz, NF	
Gęstość objętościowa	$\rho$ [kg/dm <sup>3</sup> ]	2,0	
Wytrzymałość na ściskanie	$f_b$ [N/mm <sup>2</sup> ]	$\geq 10/20$	
Norma		EN 771 - 1	
Producent			
Wymiary cegły	[mm]	$\geq 240 \times 115 \times 71$	
Minimalna grubość ściany	$h_{min}$ [mm]	$\geq 115$	







**Nośności charakterystyczne dla wszystkich kombinacji kotew (patrz Tabela B3)**

**Tabela C8: Nośność na rozciąganie przy odległości od krawędzi  $c \geq 50$  mm**

Kategoria zastosowania			w/w = w/d		d/d	
Zakres temperatury pracy			Ta	Tb	Ta	Tb
Typ i rozmiar kotwy	$h_{ef}$ [mm]	$f_b$ [N/mm <sup>2</sup> ]	$N_{Rk,p} = N_{Rk,b}$ [kN]			
Wszystkie kotwy	$\geq 50$	10	1,5 (1,5*)			
		20	2,0 (2,0*)			
	$\geq 80$	10	2,5 (3,0*)			
		20	3,5 (4,0*)			

\* Tylko czyszczenie sprężonym powietrzem (CAC)

Odpowiednia odległość od krawędzi, rozstaw oraz współczynnik grupowy  $\alpha_g$

Konfiguracja	$c \geq$ [mm]	$s_{\perp} \geq$ [mm]	$\alpha_g$ [-]	Konfiguracja	$c \geq$ [mm]	$s_{\perp} \geq$ [mm]	$\alpha_g$ [-]
	50	-	-	-	-	-	-
	50	75	1,0		115	50	1,0
-	-	-	-		50	115	1,15
	50	150	2,0		50	$3 h_{ef}$	2,0

**Hilti HIT-HY 270 z HAS-U**

**Właściwości użytkowe cegły ceramicznej pełnej Mz, NF**

Wartości charakterystyczne nośności przy obciążeniu rozciągającym oraz współczynnik grupowy

Załącznik C5



**Tabela C9: Nośność na rozciąganie przy odległości od krawędzi dla  $h_{ef} \geq 100$  mm przy  $c \geq 150$  mm**

Kategoria zastosowania			w/w = w/d		d/d	
Zakres temperatury pracy			Ta	Tb	Ta	Tb
Typ i rozmiar kotwy	$h_{ef}$ [mm]	$f_b$ [N/mm <sup>2</sup> ]	$N_{Rk,p} = N_{Rk,b}$ [kN]			
Wszystkie kotwy	$\geq 100$	10	4,0 (4,5*)			
		20	5,5 (6,0*)			

\* Tylko czyszczenie sprężonym powietrzem (CAC)

Odpowiednia odległość od krawędzi, rozstaw oraz współczynnik grupowy  $\alpha_g$

Konfiguracja	$c \geq$ [mm]	$s_{\perp} \geq$ [mm]	$\alpha_g$ [-]	Konfiguracja	$c \geq$ [mm]	$s_{  } \geq$ [mm]	$\alpha_g$ [-]
	150	-	-	-	-	-	-
	150	75	1,40		150	50	0,75
-	-	-	-		150	115	1,35
	150	150	2,0		150	3 $h_{ef}$	2,0

**Tabela C10: Nośność na ścinanie przy odległości od krawędzi  $c \geq 1,5 h_{ef}$**

Typ i rozmiar kotwy	$h_{ef}$ [mm]	$f_b$ [N/mm <sup>2</sup> ]	$V_{Rk,b} = V_{Rk,c,II}$ [kN]	$V_{Rk,c,I}$
Wszystkie kotwy	$\geq 50$	10	3,0	Obliczyć według TR 054, równanie 10
		20	4,5	
HAS-U M8; M10	$\geq 80$	10	5,0	
		20	7,0	
HAS-U M8; M10	$\geq 100$	10	8,0	
		20	11,0	
HAS-U M12; M16	$\geq 80$	10	9,0	
		20	12,0	

Odpowiednia odległość od krawędzi, rozstaw oraz współczynnik grupowy  $\alpha_g$

Konfiguracja	$c \geq$ [mm]	$s_{\perp} \geq$ [mm]	$\alpha_g$ [-]	Konfiguracja	$c \geq$ [mm]	$s_{\perp} \geq$ [mm]	$\alpha_g$ [-]
	$1,5 h_{ef}$	-	-		$1,5 h_{ef}$	-	-
	$1,5 h_{ef}$	75	1,55		$1,5 h_{ef}$	75	1,0
	$1,5 h_{ef}$	150	2,0		$1,5 h_{ef}$	3 $h_{ef}$	2,0
Konfiguracja	$c \geq$ [mm]	$s_{  } \geq$ [mm]	$\alpha_g$ [-]	Konfiguracja	$c \geq$ [mm]	$s_{  } \geq$ [mm]	$\alpha_g$ [-]
	$1,5 h_{ef}$	50	1,2		$1,5 h_{ef}$	50	1,60
	$1,5 h_{ef}$	75	1,5		$1,5 h_{ef}$	3 $h_{ef}$	2,0
	$1,5 h_{ef}$	115	2,0	-	-	-	-

Hilti HIT-HY 270 z HAS-U

Właściwości użytkowe cegły ceramicznej pełnej Mz, NF

Wartości charakterystyczne nośności przy obciążeniu rozciągającym oraz współczynnik grupowy

Załącznik C6

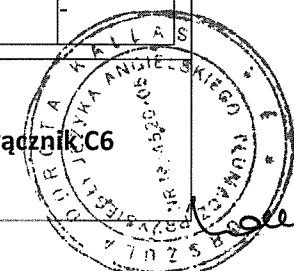

**Tabela C11: Nośność na ścinanie przy odległości od krawędzi  $c \geq 50$  mm**

Typ i rozmiar kotwy	$h_{ef}$ [mm]	$f_b$ [N/mm <sup>2</sup> ]	$V_{Rk,b} = V_{Rk,cII}$ [kN]
Wszystkie kotwy	$\geq 50$	10	3,0
		20	4,5
	$\geq 80$	10	4,0
		20	5,5

Odpowiednia odległość od krawędzi, rozstaw oraz współczynnik grupowy  $\alpha_g$

Konfiguracja	$c \geq$ [mm]	$s_{\perp} \geq$ [mm]	$\alpha_g$ [-]
	50	-	-
	50	75	1,55
	50	150	2,0
Konfiguracja	$c \geq$ [mm]	$s_{  }$ [mm]	$\alpha_g$ [-]
	50	50	1,2
	50	115	2,0

**Tabela C12: Przemieszczenia**

$h_{ef}$ [mm]	<b>N</b> [kN]	$\delta_{N0}$ [mm]	$\delta_{N\infty}$ [mm]	<b>V</b> [kN]	$\delta_{V0}$ [mm]	$\delta_{V\infty}$ [mm]
50	0,8	0,1	0,2	1,6	0,8	1,2
80	1,5	0,1	0,2	2,1	0,8	1,2
100	2,3	0,1	0,2	2,1	0,8	1,2

Hilti HIT-HY 270 z HAS-U

Właściwości użytkowe cegły ceramicznej pełnej Mz, NF

Wartości charakterystyczne nośności przy obciążeniu ścinającym oraz współczynnik grupowy  
Przemieszczenia

Załącznik C7



**Typ cegły: Cegła ceramiczna pełna Mz, 2DF**

**Tabela C13: Opis cegły**

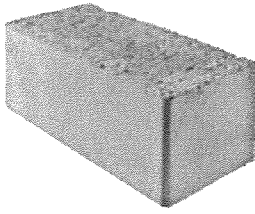
Typ cegły			Pełna Mz, 2DF	
Gęstość objętościowa	$\rho$	[kg/dm <sup>3</sup> ]	$\geq 2,0$	
Wytrzymałość na ściskanie	$f_b$	[N/mm <sup>2</sup> ]	$\geq 12/20$	
Norma			EN 771 - 1	
Producent				
Wymiary cegły	[mm]		$\geq 240 \times 115 \times 113$	
Minimalna grubość ściany	$h_{min}$	[mm]	$\geq 115$	





**Nośności charakterystyczne dla wszystkich kombinacji kotew (patrz Tabela B3)**

**Tabela C14: Nośność na rozciąganie przy odległości od krawędzi  $c \geq 115$  mm**

Kategoria zastosowania			w/w = w/d		d/d	
Zakres temperatury pracy			Ta	Tb	Ta	Tb
Typ i rozmiar kotwy	$h_{ef}$ [mm]	$f_b$ [N/mm <sup>2</sup> ]	$N_{Rk,p} = N_{Rk,b}$ [kN]			
Wszystkie kotwy	$\geq 50$	12	2,5 (3,0*)			
		20	2,5 (3,0*)			
	$\geq 80$	12	3,5 (4,0*)			
		20	4,5 (5,5*)			
	$\geq 100$	12	6,0 (7,0*)			
		20	7,0 (8,0*)			

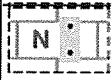
\* Tylko czyszczenie sprężonym powietrzem (CAC)

**Odpowiednia odległość od krawędzi, rozstaw oraz współczynnik grupowy  $\alpha_g$**

Konfiguracja	$c \geq$ [mm]	$s_{\perp} \geq$ [mm]	$\alpha_g$ [-]	Konfiguracja	$c \geq$ [mm]	$s_{  } \geq$ [mm]	$\alpha_g$ [-]
	115	-	-	-	-	-	-
	115	75	1,0		115	75	1,50
	115	115	1,60	-	-	-	-
	115	3 $h_{ef}$	2,0		115	3 $h_{ef}$	2,0

**Hilti HIT-HY 270 z HAS-U**

**Właściwości użytkowe cegły ceramicznej pełnej Mz, 2DF**

Wartości charakterystyczne nośności przy obciążeniu rozciągającym oraz współczynnik grupowy

Załącznik C8

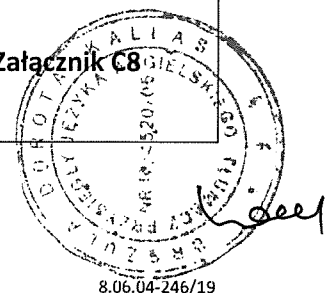

**Tabela C15: Nośność na rozciąganie przy odległości od krawędzi  $c \geq 50$  mm**

Kategoria zastosowania			w/w = w/d		d/d	
Zakres temperatury pracy			Ta	Tb	Ta	Tb
Typ i rozmiar kotwy	$h_{ef}$ [mm]	$f_b$ [N/mm <sup>2</sup> ]	$N_{RR,p} = N_{RR,b}$ [kN]			
Wszystkie kotwy	$\geq 50$	12	1,5 (1,5*)			
		20	2,0 (2,0*)			
	$\geq 80$	12	3,0 (3,5*)			
		20	3,5 (4,0*)			

\* Tylko czyszczenie sprężonym powietrzem (CAC)

Odpowiednia odległość od krawędzi, rozstaw oraz współczynnik grupowy  $\alpha_g$

Konfiguracja	$c \geq$ [mm]	$s_{\perp} \geq$ [mm]	$\alpha_g$ [-]	Konfiguracja	$c \geq$ [mm]	$s_{  } \geq$ [mm]	$\alpha_g$ [-]
	50	-	-	-	-	-	-
	50	75	1,10		115	50	1,0
	50	115	1,45		50	115	1,15
	50	3 $h_{ef}$	2,0		50	3 $h_{ef}$	2,0

**Tabela C16: Nośność na ścinanie przy odległości od krawędzi  $c \geq 1,5 h_{ef}$**

Typ i rozmiar kotwy	$h_{ef}$ [mm]	$f_b$ [N/mm <sup>2</sup> ]	$V_{RK,b} = V_{RK,c II}$ [kN]	$V_{RK,c \perp}$
Wszystkie kotwy	$\geq 50$	12	5,5	Obliczyć według TR 054, równanie 10 (dla $h_{ef} > 80$ mm obliczyć przy $h_{ef} = 80$ mm)
		20	7,0	
HAS-U M8; M10	$\geq 80$	12	8,0	
		20	10,0	
HAS-U M12	$\geq 80$	12	10,5	
		20	12,0	
HAS-U M16	$\geq 80$	12	12,0	
		20	12,0	

Odpowiednia odległość od krawędzi, rozstaw oraz współczynnik grupowy  $\alpha_g$

Konfiguracja	$c \geq$ [mm]	$s_{\perp} c$ [mm]	$\alpha_g$ [-]	Konfiguracja	$c \geq$ [mm]	$s_{\perp} \geq$ [mm]	$\alpha_g$ [-]
	1,5 $h_{ef}$	-	-		1,5 $h_{ef}$	-	-
	1,5 $h_{ef}$	75	0,85		1,5 $h_{ef}$	115	0,75
	1,5 $h_{ef}$	3 $h_{ef}$	2,0		1,5 $h_{ef}$	3 $h_{ef}$	2,0
Konfiguracja	$c \geq$ [mm]	$s_{  }$ [mm]	$\alpha_g$ [-]	Konfiguracja	$c \geq$ [mm]	$s_{  }$ [mm]	$\alpha_g$ [-]
	1,5 $h_{ef}$	115	1,60		1,5 $h_{ef}$	115	0,8
	1,5 $h_{ef}$	3 $h_{ef}$	2,0		1,5 $h_{ef}$	3 $h_{ef}$	2,0

Hilti HIT-HY 270 z HAS-U

Właściwości użytkowe cegły ceramicznej pełnej Mz, 2ZF

Wartości charakterystyczne nośności przy obciążeniu rozciągającym i ścinającym oraz współczynnik grupowy

Załącznik C9

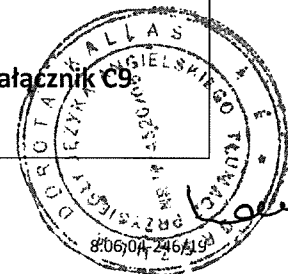

**Tabela C17: Nośność na ścinanie przy odległości od krawędzi  $c \geq 50$  mm**

Typ i rozmiar kotwy	$h_{ef}$ [mm]	$f_b$ [N/mm <sup>2</sup> ]	$V_{Rk,b} = V_{Rk,cII}$ [kN]
Wszystkie kotwy	$\geq 50$	12	3,0
		20	4,0
Wszystkie kotwy	$\geq 80$	12	4,5
		20	5,5

Odpowiednia odległość od krawędzi, rozstaw oraz współczynnik grupowy  $\alpha_g$

Konfiguracja	$c \geq$ [mm]	$S_{\perp} \geq$ [mm]	$\alpha_g$ [-]
	50	-	-
	50	75	0,70
	50	115	1,5
	50	3 $h_{ef}$	2,0
Konfiguracja	$c \geq$ [mm]	$s_{II}$ [mm]	$\alpha_g$ [-]
	50	115	2,0

**Tabela C16: Przemieszczenia**

$h_{ef}$	<b>N</b>	$\delta_{NO}$	$\delta_{Nco}$	<b>V</b>	$\delta_{v0}$	$\delta_{vco}$
[mm]	[kN]	[mm]	[mm]	[kN]	[mm]	[mm]
50	0,9	0,1	0,2	1,9	0,6	0,9
80	1,3	0,2	0,4	2,8	1,0	1,5
100	1,7	0,3	0,6	2,8	1,0	1,5

Hilti HIT-HY 270 z HAS-U

Właściwości użytkowe cegły ceramicznej pełnej Mz, 2DF

Wartości charakterystyczne nośności przy obciążeniu ścinającym oraz współczynnik grupowy Przemieszczenia

Załącznik C10





**Typ cegły: Cegła silikatowa pełna KS, 2DF**

**Tabela C19: Opis cegły**

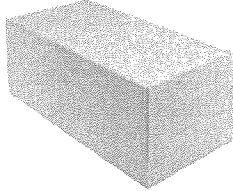





Typ cegły			Pełna KS, 2DF	
Gęstość objętościowa	$\rho$	[kg/dm <sup>3</sup> ]	$\geq 2,0$	
Wytrzymałość na ściskanie	$f_b$	[N/mm <sup>2</sup> ]	$\geq 12/28$	
Norma			EN 771 - 2	
Producent				
Wymiary cegły	[mm]		$\geq 240 \times 115 \times 113$	
Minimalna grubość ściany	$h_{min}$	[mm]	$\geq 115$	

**Nośności charakterystyczne dla wszystkich kombinacji kotew (patrz Tabela B3)**

**Tabela C20: Nośność na rozciąganie przy odległości od krawędzi  $c \geq 115$  mm**

Kategoria zastosowania			w/w = w/d		d/d	
Zakres temperatury pracy			Ta	Tb	Ta	Tb
Typ i rozmiar kotwy	$h_{ef}$ [mm]	$f_b$ [N/mm <sup>2</sup> ]	$N_{Rk,p} = N_{Rk,b}$ [kN]			
Wszystkie kotwy	$\geq 50$	12	-	-	6,0	5,0
		28	-	-	9,0	7,5

**Odpowiednia odległość od krawędzi, rozstaw oraz współczynnik grupowy  $\alpha_g$**



Konfiguracja	$c \geq$ [mm]	$s_{\perp} \geq$ [mm]	$\alpha_g$ [-]	Konfiguracja	$c \geq$ [mm]	$s_{  } \geq$ [mm]	$\alpha_g$ [-]
	115	-	-	-	-	-	-
	115	50	1,0		115	50	1,0
	115	115	1,45	-	-	-	-
	115	150	2,0		115	115(H)* 240(S)*	2,0

\* (H) = główka [Header], (S) = wozówka [Stretcher]

**Tabela C21: Nośność na rozciąganie przy odległości od krawędzi  $c \geq 50$  mm**

Kategoria zastosowania			w/w:= w/d		d/d	
Zakres temperatury pracy			Ta	Tb	Ta	Tb
Typ i rozmiar kotwy	$h_{ef}$ [mm]	$f_b$ [N/mm <sup>2</sup> ]	$N_{Rk,p} = N_{Rk,b}$ [kN]			
Wszystkie kotwy	$\geq 50$	12	-	-	4,0	3,5
		28	-	-	6,5	5,5

**Odpowiednia odległość od krawędzi, rozstaw oraz współczynnik grupowy  $\alpha_g$**

Konfiguracja	$c \geq$ [mm]	$s_{\perp} \geq$ [mm]	$\alpha_g$ [-]	Konfiguracja	$c \geq$ [mm]	$s_{  } \geq$ [mm]	$\alpha_g$ [-]
	50	-	-	-	-	-	-
	50	115	2,0		50	115(H)* 240(S)*	2,0

\* (H) = główka [Header], (S) = wozówka [Stretcher]

**Hilti HIT-HY 270 z HAS-U**

**Właściwości użytkowe cegły silikatowej pełnej KS, 2DF**

Wartości charakterystyczne nośności przy obciążeniu rozciągającym oraz współczynnik grupowy

Załącznik C.11



**Tabela C22: Nośność na ścinanie przy odległości od krawędzi  $c \geq 115$  mm**

Typ i rozmiar kotwy	$h_{ef}$ [mm]	$f_b$ [N/mm <sup>2</sup> ]	$V_{Rk,b} = V_{Rk,c II}$ [kN]	$V_{Rk,c \perp}$
Wszystkie kotwy	$\geq 50$	12	6,0	Obliczyć według TR 054, równanie 10
		28	9,0	

Odpowiednia odległość od krawędzi, rozstaw oraz współczynnik grupowy  $\alpha_g$

Konfiguracja	$c \geq$ [mm]	$s_{\perp} \geq$ [mm]	$\alpha_g$ [-]	Konfiguracja	$c \geq$ [mm]	$s_{\perp} \geq$ [mm]	$\alpha_g$ [-]
	115	-	-		115	-	-
	115	50	0,45		115	50	0,45
	115	115	2,0		115	115	2,0
Konfiguracja	$c \geq$ [mm]	$s_{II}$ [mm]	$\alpha_g$ [-]	Konfiguracja	$c \geq$ [mm]	$s_{II}$ [mm]	$\alpha_g$ [-]
	115	50	0,45		115	50	0,45
	115	115(H)* 240(S)*	2,0		115	115(H)* 240(S)*	2,0

\* (H) = główka [Header], (S) = wozówka [Stretcher]

**Tabela C23: Nośność na ścinanie przy odległości od krawędzi  $c \geq 50$  mm**

Typ i rozmiar kotwy	$h_{ef}$ [mm]	$f_b$ [N/mm <sup>2</sup> ]	$V_{Rk,b} = V_{Rk,c II} = V_{Rk,c \perp}$ [kN]
Wszystkie kotwy	$\geq 50$	12	3,0
		28	4,5

Odpowiednia odległość od krawędzi, rozstaw oraz współczynnik grupowy  $\alpha_g$

Konfiguracja	$c \geq$ [mm]	$s_{\perp} \geq$ [mm]	$\alpha_g$ [-]	Konfiguracja	$c \geq$ [mm]	$s_{\perp} \geq$ [mm]	$\alpha_g$ [-]
	50	-	-		50	-	-
	50	115	2,0		50	115	2,0
Konfiguracja	$c \geq$ [mm]	$s_{II}$ [mm]	$\alpha_g$ [-]	Konfiguracja	$c \geq$ [mm]	$s_{II}$ [mm]	$\alpha_g$ [-]
	50	115(H)* 240(S)*	2,0		50	115(H)* 240(S)*	2,0

\* (H) = główka [Header], (S) = wozówka [Stretcher]

**Tabela C24: Przemieszczenia**

$h_{ef}$	<b>N</b>	$\delta_{N0}$	$\delta_{N\infty}$	<b>V</b>	$\delta_{V0}$	$\delta_{V\infty}$
[mm]	[kN]	[mm]	[mm]	[kN]	[mm]	[mm]
>50	2,5	0,3	0,6	2,5	1,0	1,5

Hilti HIT-HY 270 z HAS-U

Właściwości użytkowe cegły silikatowej pełnej KS, 2DF

Wartości charakterystyczne nośności przy obciążeniu rozciągającym i ścinającym oraz współczynnik grupowy

Przemieszczenia

Załącznik C12







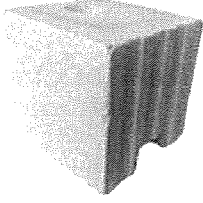

**Typ cegły: Cegła silikatowa pełna KS, 8DF**

**Tabela C25: Opis cegły**

Typ cegły			Pełna KS, 8DF	
Gęstość objętościowa	$\rho$	[kg/dm <sup>3</sup> ]	≥ 2,0	
Wytrzymałość na ściskanie	$f_b$	[N/mm <sup>2</sup> ]	≥12/20/28	
Norma			EN 771 - 2	
Producent				
Wymiary cegły			[mm] ≥ 248 x 240 x 248	
Minimalna grubość ściany	$h_{min}$	[mm]	≥ 240	

**Nośności charakterystyczne dla wszystkich kombinacji kotew (patrz Tabela B3)**

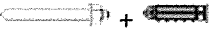
**Tabela C26: Nośność na rozciąganie przy odległości od krawędzi  $c \geq 120$  mm**

Kategoria zastosowania			w/w = w/d		d/d	
Zakres temperatury pracy			Ta	Tb	Ta	Tb
Typ i rozmiar kotwy	$h_{ef}$ [mm]	$f_b$ [N/mm <sup>2</sup> ]	$N_{Rk,p} = N_{Rk,b}$ [kN]			
Wszystkie kotwy	≥ 50	12	-	-	7,0	5,5
		20	-	-	9,0	7,5
		28	-	-	10,5	8,5
HAS-U  M8, M10	≥ 80	12	-	-	8,5	7,0
		20	-	-	11,0	9,0
		28	-	-	12,0	10,5
HAS-U  M12	≥ 80	12	-	-	11,5	9,5
		20	-	-	12,0	12,0
HAS-U + HIT-SC  M8, M10	≥ 80	28	-	-	12,0	12,0
		12	-	-	12,0	12,0
HAS-U  M16	≥ 80	20	-	-	12,0	12,0
		28	-	-	12,0	12,0
		12	-	-	12,0	12,0
HAS-U + HIT-SC  M12, M16	≥ 80	20	-	-	12,0	12,0
		28	-	-	12,0	12,0
		12	-	-	12,0	12,0
HAS-U  M8, M10	≥ 100	12	-	-	12,0	11,0
		20	-	-	12,0	12,0
		28	-	-	12,0	12,0

Hilti HIT-HY 270 z HAS-U

Właściwości użytkowe cegły silikatowej pełnej KS, 8DF

Wartości charakterystyczne nośności przy obciążeniu rozciągającym

Załącznik C13





Tabela C26 ciąg dalszy

 	M12, M16	≥ 100	12	-	-	12,0	12,0
	M8 do V16		20	-	-	12,0	12,0
			28	-	-	12,0	12,0

Odpowiednia odległość od krawędzi, rozstaw oraz współczynnik grupowy  $\alpha_g$

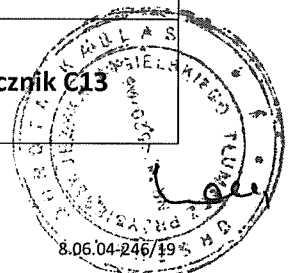

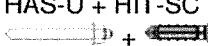





Konfiguracja	c ≥ [mm]	s <sub>⊥</sub> ≥ [mm]	$\alpha_g$ [-]	Konfiguracja	c ≥ [mm]	s <sub>  </sub> ≥ [mm]	$\alpha_g$ [-]
	120	-	-	-	-	-	-
	120	3 h <sub>ef</sub>	2,0		120	3 h <sub>ef</sub>	2,0

Tabela C27: Nośność na rozciąganie przy odległości od krawędzi c ≥ 50 mm

Kategoria zastosowania			w/w = w/d		d/d	
Zakres temperatury pracy			Ta	Tb	Ta	Tb
Typ i rozmiar kotwy	h <sub>ef</sub> [mm]	f <sub>b</sub> [N/mm <sup>2</sup> ]	N <sub>RK,p</sub> = N <sub>RK,b</sub> [kN]			
Wszystkie kotwy	≥ 50	12	-	-	4,0	3,5
		20	-	-	5,5	4,5
		28	-	-	6,5	5,0
 M8, M10	≥ 80	12	-	-	5,0	4,0
		20	-	-	6,5	5,5
		28	-	-	7,5	6,5
  M12 M8, M10	≥ 80	12	-	-	7,0	5,5
		20	-	-	9,0	7,5
		28	-	-	10,5	8,5
  M16 M12, M16	≥ 80	12	-	-	10,0	8,0
		20	-	-	12,0	10,5
		28	-	-	12,0	12,0
 M8, M10	≥ 100	12	-	-	8,0	6,5
		20	-	-	10,5	8,5
		28	-	-	12,0	10,0

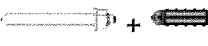
Hilti HIT-HY 270 z HAS-U

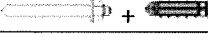

Właściwości użytkowe cegły silikatowej pełnej KS, 8DF

Wartości charakterystyczne nośności przy obciążeniu rozciągającym oraz współczynnik grupowy

Załącznik C14

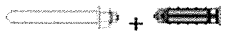

Tabela C27 ciąg dalszy

HAS-U	M12	≥ 100	12	-	-	9,5	8,0
			20	-	-	12,0	10,0
HAS-U + HIT-SC	M8, M10		28	-	-	12,0	12,0
							
HAS-U	M16		12	-	-	12,0	10,5
HAS-U + HIT-SC	M12, M16		20	-	-	12,0	12,0
		28	-	-	12,0	12,0	

Odpowiednia odległość od krawędzi, rozstaw oraz współczynnik grupowy  $\alpha_g$











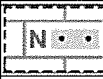

Konfiguracja	$c \geq$ [mm]	$s_{\perp} \geq$ [mm]	$\alpha_g$ [-]	Konfiguracja	$c \geq$ [mm]	$s_{\parallel} \geq$ [mm]	$\alpha_g$ [-]
	50	-	-	-	-	-	-
	50	50	1,0		50	50	1,0
	50	3 $h_{ef}$	2,0		50	3 $h_{ef}$	2,0

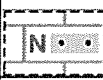
Tabela C28: Nośność na ścinanie przy odległości od krawędzi  $c \geq 120$  mm (dla  $V_{II}$ ) oraz  $c \geq 1,5 h_{ef}$  (dla  $V_{\perp}$ )

Typ i rozmiar kotwy	$h_{ef}$ [mm]	$f_b$ [N/mm <sup>2</sup> ]	$V_{Rk,b} = V_{Rk,c II}$ [kN]	$V_{Rk,c \perp}$
HAS-U	≥ 50	12	9,0	Obliczyć według TR 054, równanie 10
		20	12,0	
		28	12,0	
HAS-U		12	12,0	
HAS-U + HIT-SC		20	12,0	
		28	12,0	

Odpowiednia odległość od krawędzi, rozstaw oraz współczynnik grupowy  $\alpha_g$

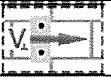
Konfiguracja	$c \geq$ [mm]	$s_{\perp} \geq$ [mm]	$\alpha_g$ [-]	Konfiguracja	$c \geq$ [mm]	$s_{\perp} \geq$ [mm]	$\alpha_g$ [-]
	120	-	-		1,5 $h_{ef}$	-	-
	120	3 $h_{ef}$	2,0		1,5 $h_{ef}$	3 $h_{ef}$	2,0
Konfiguracja	$c \geq$ [mm]	$s_{\parallel} \geq$ [mm]	$\alpha_g$ [-]	Konfiguracja	$c \geq$ [mm]	$s_{\parallel} \geq$ [mm]	$\alpha_g$ [-]
	120	3 $h_{ef}$	2,0		1,5 $h_{ef}$	3 $h_{ef}$	2,0

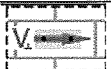
Hilti HIT-HY 270 z HAS-U

Właściwości użytkowe cegły silikatowej pełnej KS, 8DF

Wartości charakterystyczne nośności przy obciążeniu rozciągającym i ścinającym oraz współczynnik grupowy

Załącznik C15



**Tabela C29: Nośność na ścinanie przy odległości od krawędzi  $c \geq 50$  mm**

Typ i rozmiar kotwy	$h_{ef}$ [mm]	$f_b$ [N/mm <sup>2</sup> ]	$V_{Rk,b} = V_{Rk,c \parallel} = V_{Rk,c \perp}$ [kN]
Wszystkie kotwy	$\geq 50$	12	3,0
		20	4,0
		28	4,5

Odpowiednia odległość od krawędzi, rozstaw oraz współczynnik grupowy  $\alpha_g$

Konfiguracja	$c \geq$ [mm]	$s_{\perp} \geq$ [mm]	$\alpha_g$ [-]	Konfiguracja	$c \geq$ [mm]	$s_{\perp} \geq$ [mm]	$\alpha_g$ [-]
	50	-	-		50	-	-
	50	250	2,0		50	250	2,0
Konfiguracja	$c \geq$ [mm]	$s_{\parallel} \geq$ [mm]	$\alpha_g$ [-]	Konfiguracja	$c \geq$ [mm]	$s_{\parallel} \geq$ [mm]	$\alpha_g$ [-]
	50	250	2,0		50	250	2,0

**Tabela C30: Przemieszczenia**

$h_{ef}$	<b>N</b>	$\delta_{N0}$	$\delta_{N\infty}$	<b>V</b>	$\delta_{V0}$	$\delta_{V\infty}$
[mm]	[kN]	[mm]	[mm]	[kN]	[mm]	[mm]
50	2,3	0,10	0,20	3,4	2,8	4,2
80	3,4	0,15	0,30	3,4	2,8	4,2
100	3,4	0,15	0,30	3,4	2,8	4,2

Hilti HIT-HY 270 z HAS-U

Właściwości użytkowe cegły silikatowej pełnej KS, 8DF

Wartości charakterystyczne nośności przy obciążeniu ścinającym oraz współczynnik grupowy

Przemieszczenia

Załącznik C16

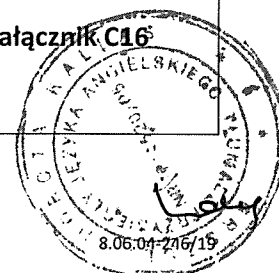

**Typ cegły: Cegła pełna z betonu lekkiego Vbl, 2DF**

**Tabela C31: Opis cegły**

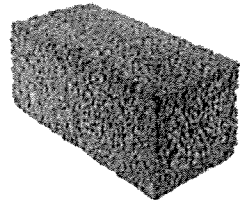
Typ cegły			Pełna Vbl, 2DF	
Gęstość objętościowa	$\rho$	[kg/dm <sup>3</sup> ]	$\geq 0,9$	
Wytrzymałość na ściskanie	$f_b$	[N/mm <sup>2</sup> ]	$\geq 4/6$	
Norma			EN 771-3	
Producent				
Wymiary cegły	[mm]		$\geq 240 \times 115 \times 113$	
Minimalna grubość ściany	$h_{min}$	[mm]	$\geq 115$	



**Nośności charakterystyczne dla wszystkich kombinacji kotew (patrz Tabela B3)**

**Tabela C32: Nośność na rozciąganie przy odległości od krawędzi  $c \geq 115$  mm**

Kategoria zastosowania			w/w = w/d		d/d		
Zakres temperatury pracy			Ta	Tb	Ta	Tb	
Typ i rozmiar kotwy	$h_{ef}$ [mm]	$f_b$ [N/mm <sup>2</sup> ]	$N_{Rk,p} = N_{Rk,b}$ [kN]				
Wszystkie kotwy	$\geq 50$	4	3,0	2,0	3,0 (3,5*)	2,5	
		6	3,5	3,0	4,0	3,0 (3,5*)	
	$\geq 80$	4	4,5	3,5	3,5	5,0	4,0 (4,5*)
		6	5,5	4,5	4,5	6,0 (6,5*)	5,0 (5,5*)
	$\geq 100$	4	6,0	6,0	5,0	6,5 (7,0*)	5,5 (6,0*)
		6	7,5	6,0	6,0	8,0 (8,5*)	6,5 (7,0*)

\* Wyłącznie czyszczenie sprężonym powietrzem (CAC)







**Odpowiednia odległość od krawędzi, rozstaw oraz współczynnik grupowy  $\alpha_g$**

Konfiguracja	$c \geq$ [mm]	$s_{\perp} \geq$ [mm]	$\alpha_g$ [-]	Konfiguracja	$c \geq$ [mm]	$s_{  } \geq$ [mm]	$\alpha_g$ [-]
	115	-	-	-	-	-	-
	115	3 $h_{ef}$	2,0		115	3 $h_{ef}$	2,0

**Tabela C33: Nośność na rozciąganie przy odległości od krawędzi  $c \geq 50$  mm**

Kategoria zastosowania			w/w = w/d		d/d	
Zakres temperatury pracy			Ta	Tb	Ta	Tb
Typ i rozmiar kotwy	$h_{ef}$ [mm]	$f_b$ [N/mm <sup>2</sup> ]	$N_{Rk,p} = N_{Rk,b}$ [kN]			
Wszystkie kotwy	$\geq 50$	4	1,5	1,2	1,5	1,5
		6	2,0	1,5	2,0	1,5

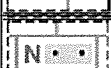
**Odpowiednia odległość od krawędzi, rozstaw oraz współczynnik grupowy  $\alpha_g$**

Konfiguracja	$c \geq$ [mm]	$s_{\perp} \geq$ [mm]	$\alpha_g$ [-]	Konfiguracja	$c \geq$ [mm]	$s_{  } \geq$ [mm]	$\alpha_g$ [-]
	50	-	-	-	-	-	-
	50	115	1,0		50	115	1,0
	115	50	1,0		115	50	1,0
	50	3 $h_{ef}$	2,0		50	3 $h_{ef}$	2,0

**Hilti HIT-HY 270 z HAS-U**

**Właściwości użytkowe cegły pełnej z betonu lekkiego Vbl, 2DF**

Wartości charakterystyczne nośności przy obciążeniu rozciągającym oraz współczynnik grupowy

Załącznik C17

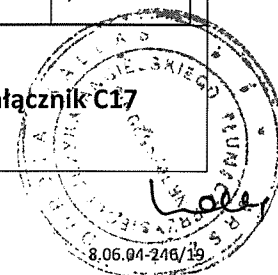

**Tabela C34: Nośność na ścinanie przy odległości od krawędzi  $c \geq 115$  mm (dla  $V_{II}$ ) oraz  $c \geq 1,5 h_{ef}$  (for  $V_{I}$ )**

Typ i rozmiar kotwy	$h_{ef}$ [mm]	$f_b$ [N/mm <sup>2</sup> ]	$V_{Rk,b} = V_{Rk,c II}$ [kN]	$V_{Rk,c \perp}$
HAS-U M8	$\geq 50$	4	2,0	Obliczyć według TR 054, równanie 10
		6	2,5	
HAS-U M10 do M16		4	2,5	
		6	3,0	

Odpowiednia odległość od krawędzi, rozstaw oraz współczynnik grupowy  $\alpha_g$

Konfiguracja	$c \geq$ [mm]	$s_{\perp} \geq$ [mm]	$\alpha_g$ [-]	Konfiguracja	$c \geq$ [mm]	$s_{\perp} \geq$ [mm]	$\alpha_g$ [-]
	115	-	-		$1,5 h_{ef}$	-	-
	115	$3 h_{ef}$	2,0		$1,5 h_{ef}$	$3 h_{ef}$	2,0
Konfiguracja	$c \geq$ [mm]	$s_{\parallel} \geq$ [mm]	$\alpha_g$ [-]	Konfiguracja	$c \geq$ [mm]	$s_{\parallel} \geq$ [mm]	$\alpha_g$ [-]
	115	$3 h_{ef}$	2,0		$1,5 h_{ef}$	$3 h_{ef}$	2,0

**Tabela C35: Nośność na ścinanie przy odległości od krawędzi  $c \geq 50$  mm**

Typ i rozmiar kotwy	$h_{ef}$ [mm]	$f_b$ [N/mm <sup>2</sup> ]	$V_{Rk,b} = V_{Rk,c II} = V_{Rk,c \perp}$ [kN]
Wszystkie kotwy	$\geq 50$	4	1,20
		6	1,50

Odpowiednia odległość od krawędzi, rozstaw oraz współczynnik grupowy  $\alpha_g$

Konfiguracja	$c \geq$ [mm]	$s_{\perp} \geq$ [mm]	$\alpha_g$ [-]	Konfiguracja	$c \geq$ [mm]	$s_{\perp} \geq$ [mm]	$\alpha_g$ [-]
	50	-	-		50	-	-
	115	50	1,0		115	50	1,0
	50	115	1,0		50	115	1,0
	50	$3 h_{ef}$	2,0		50	$3 h_{ef}$	2,0
Konfiguracja	$c \geq$ [mm]	$s_{\parallel} \geq$ [mm]	$\alpha_g$ [-]	Konfiguracja	$c \geq$ [mm]	$s_{\parallel} \geq$ [mm]	$\alpha_g$ [-]
	115	50	1,0		115	50	1,0
	50	115	1,0		50	115	1,0
	50	$3 h_{ef}$	2,0		50	$3 h_{ef}$	2,0

**Tabela C36: Przemieszczenia**

$h_{ef}$	N	$\delta_{N0}$	$\delta_{N\infty}$	V	$\delta_{V0}$	$\delta_{V\infty}$
[mm]	[kN]	[mm]	[mm]	[kN]	[mm]	[mm]
$\geq 50$	2,5	0,3	0,6	1,8	2,0	3,0

Hilti HIT-HY 270 z HAS-U

**Właściwości użytkowe cegły pełnej z betonu lekkiego Vb1, 2DF**

Wartości charakterystyczne nośności przy obciążeniu rozciągającym i ścinającym  
Przemieszczenia

Załącznik C18

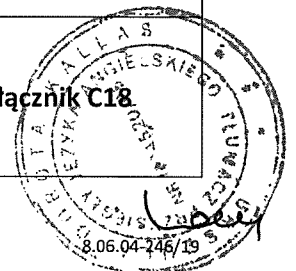



**Typ cegły: Cegła pełna z betonu zwykłego Vbn, 2DF**

**Tabela C37: Opis cegły**

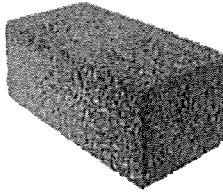

Typ cegły			Pełna Vbn, 2DF	
Gęstość objętościowa	$\rho$	[kg/dm <sup>3</sup> ]	$\geq 2,0$	
Wytrzymałość na ściskanie	$f_b$	[N/mm <sup>2</sup> ]	$\geq 6/16$	
Norma			EN 771-3	
Producent				
Wymiary cegły			[mm] $\geq 240 \times 115 \times 113$	
Minimalna grubość ściany	$h_{min}$	[mm]	$\geq 115$	

**Nośności charakterystyczne dla wszystkich kombinacji kotew (patrz Tabela B3)**

**Tabela C38: Nośność na rozciąganie przy odległości od krawędzi  $c \geq 115$  mm**

Kategoria zastosowania			w/w = w/d		d/d	
Zakres temperatury pracy			Ta	Tb	Ta	Tb
Typ i rozmiar kotwy	$h_{ef}$ [mm]	$f_b$ [N/mm <sup>2</sup> ]	$N_{Rk,p} = N_{Rk,b}$ [kN]			
Wszystkie kotwy	$\geq 50$	6	3,0	2,5	3,0	2,5
		16	5,5	4,5	5,5	4,5







**Odpowiednia odległość od krawędzi, rozstaw oraz współczynnik grupowy  $\alpha_g$**

Konfiguracja	$c \geq$ [mm]	$s_{\perp} \geq$ [mm]	$\alpha_g$ [-]	Konfiguracja	$c \geq$ [mm]	$s_{\parallel} \geq$ [mm]	$\alpha_g$ [-]
	115	-	-	-	-	-	-
	115	3 $h_{ef}$	2,0		115	3 $h_{ef}$	2,0

**Tabela C39: Nośność na rozciąganie przy odległości od krawędzi  $c \geq 50$  mm**

Kategoria zastosowania			w/w = w/d		d/d	
Zakres temperatury pracy			Ta	Tb	Ta	Tb
Typ i rozmiar kotwy	$h_{ef}$ [mm]	$f_b$ [N/mm <sup>2</sup> ]	$N_{Rk,p} = N_{Rk,b}$ [kN]			
Wszystkie kotwy	$\geq 50$	6	1,5	1,2	1,5	1,2
		16	2,5	2,0	2,5	2,0

**Odpowiednia odległość od krawędzi, rozstaw oraz współczynnik grupowy  $\alpha_g$**

Konfiguracja	$c \geq$ [mm]	$s_{\perp} \geq$ [mm]	$\alpha_g$ [-]	Konfiguracja	$c \geq$ [mm]	$s_{\parallel} \geq$ [mm]	$\alpha_g$ [-]
	50	-	-	-	-	-	-
	50	115	1,0		50	115	1,0
	115	50	1,0		115	50	1,0
	50	3 $h_{ef}$	2,0		50	3 $h_{ef}$	2,0

**Hilti HIT-HY 270 z HAS-U**

**Właściwości użytkowe cegły pełnej z betonu zwykłego Vbn, 2DF**

Wartości charakterystyczne nośności przy obciążeniu rozciągającym oraz współczynnik grupowy

Załącznik C19

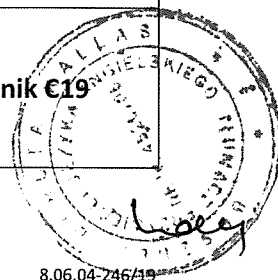

**Tabela C40: Nośność na ścinanie przy odległości od krawędzi  $c \geq 115$  mm (dla  $V_{II}$ ) oraz  $c \geq 1,5 h_{ef}$  (dla  $V_{\perp}$ )**

Typ i rozmiar kotwy	$h_{ef}$ [mm]	$f_b$ [N/mm <sup>2</sup> ]	$V_{Rk,b} = V_{Rk,c \parallel}$ [kN]	$V_{Rk,c \perp}$
Wszystkie kotwy	$\geq 50$	6	4,0	Obliczyć według TR 054, równanie 10
		16	6,5	

**Odpowiednia odległość od krawędzi, rozstaw oraz współczynnik grupowy  $\alpha_g$**

Konfiguracja	$c \geq$ [mm]	$s_{\perp} \geq$ [mm]	$\alpha_g$ [-]	Konfiguracja	$c \geq$ [mm]	$s_{\perp} \geq$ [mm]	$\alpha_g$ [-]
	115	-	-		$1,5 h_{ef}$	-	-
	115	$3 h_{ef}$	2,0		$1,5 h_{ef}$	$3 h_{ef}$	2,0
Konfiguracja	$c \geq$ [mm]	$s_{\parallel} \geq$ [mm]	$\alpha_g$ [-]	Konfiguracja	$c \geq$ [mm]	$s_{\parallel} \geq$ [mm]	$\alpha_g$ [-]
	115	$3 h_{ef}$	2,0		$1,5 h_{ef}$	$3 h_{ef}$	2,0

**Tabela C41: Nośność na ścinanie przy odległości od krawędzi  $c \geq 50$  mm**

Typ i rozmiar kotwy	$h_{ef}$ [mm]	$f_b$ [N/mm <sup>2</sup> ]	$V_{Rk,b} = V_{Rk,c \parallel} = V_{Rk,c \perp}$
Wszystkie kotwy	$\geq 50$	4	1,5
		6	3,0

**Odpowiednia odległość od krawędzi, rozstaw oraz współczynnik grupowy  $\alpha_g$**

Konfiguracja	$c \geq$ [mm]	$s_{\perp} \geq$ [mm]	$\alpha_g$ [-]	Konfiguracja	$c \geq$ [mm]	$s_{\perp} \geq$ [mm]	$\alpha_g$ [-]
	50	-	-		50	-	-
	115	50	1,0		115	50	1,0
	50	115	1,0		50	115	1,0
	50	$3 h_{ef}$	2,0		50	$3 h_{ef}$	2,0
Konfiguracja	$c \geq$ [mm]	$s_{\parallel} \geq$ [mm]	$\alpha_g$ [-]	Konfiguracja	$c \geq$ [mm]	$s_{\parallel} \geq$ [mm]	$\alpha_g$ [-]
	115	50	1,0		115	50	1,0
	50	115	1,0		50	115	1,0
	50	$3 h_{ef}$	2,0		50	$3 h_{ef}$	2,0

**Tabela C42: Przemieszczenia**

$h_{ef}$	N	$\delta_{N0}$	$\delta_{N\infty}$	V	$\delta_{V0}$	$\delta_{V\infty}$
[mm]	[kN]	[mm]	[mm]	[kN]	[mm]	[mm]
$\geq 50$	1,5	0,3	0,6	1,8	2,0	3,0

Hilti HIT-HY 270 z HAS-U

Właściwości użytkowe cegły pełnej z betonu zwykłego Vbn, 2DF

Wartości charakterystyczne nośności przy obciążeniu ścinającym oraz współczynnik grupowy  
Przemieszczenia

Załącznik C20

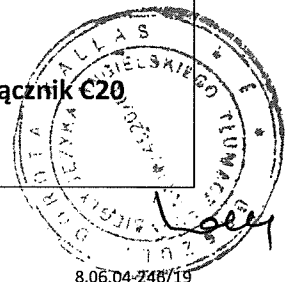

**Typ cegły: Cegła ceramiczna otworowa Hlz, 10DF**

**Tabela C43: Opis cegły**

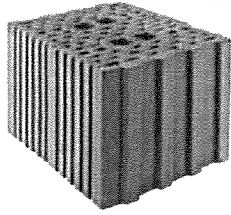
Typ cegły			Hlz12-1,4-10 DF	 <p>Ilustracja cegły, patrz Tabela B4</p>
Gęstość objętościowa	$\rho$	[kg/dm <sup>3</sup> ]	$\geq 1,4$	
Wytrzymałość na ściskanie	$f_b$	[N/mm <sup>2</sup> ]	$\geq 12/20$	
Norma			EN 771 - 1	
Producent			Rapis (D)	
Wymiary cegły			[mm] 300 x 240 x 238	
Minimalna grubość ściany	$h_{min}$	[mm]	$\geq 240$	



**Nośności charakterystyczne dla wszystkich kombinacji kotew (patrz Tabela B3)**

**Tabela C44: Nośność na rozciąganie przy odległości od krawędzi  $c \geq 150$  mm**

Kategoria zastosowania			w/w = w/d		d/d	
Zakres temperatury pracy			Ta	Tb	Ta	Tb
Typ i rozmiar kotwy	$h_{ef}$ [mm]	$f_b$ [N/mm <sup>2</sup> ]	$N_{RK,p} = N_{RK,b}$ [kN]			
Wszystkie kotwy	$\geq 80$	12	5,5 (6,0*)			
		20	7,0 (8,0*)			

\* Wyłącznie czyszczenie sprężonym powietrzem (CAC)

**Odpowiednia odległość od krawędzi, rozstaw oraz współczynnik grupowy  $\alpha_g$**





Konfiguracja	$c \geq$ [mm]	$s_{\perp} \geq$ [mm]	$\alpha_g$ [-]	Konfiguracja	$c \geq$ [mm]	$s_{  } \geq$ [mm]	$\alpha_g$ [-]
	150	-	-	-	-	-	-
	150	240	2,0		150	300	2,0

**Tabela C45: Nośność na rozciąganie przy odległości od krawędzi  $c \geq 50$  mm**

Kategoria zastosowania			w/w = w/d		d/d	
Zakres temperatury pracy			Ta	Tb	Ta	Tb
Typ i rozmiar kotwy	$h_{ef}$ [mm]	$f_b$ [N/mm <sup>2</sup> ]	$N_{RK,p} = N_{RK,b}$ [kN]			
Wszystkie kotwy	$\geq 80$	12	1,5 (2,0*)			
		20	2,0 (2,5*)			

\* Wyłącznie czyszczenie sprężonym powietrzem (CAC)

**Odpowiednia odległość od krawędzi, rozstaw oraz współczynnik grupowy  $\alpha_g$**

Konfiguracja	$c \geq$ [mm]	$s_{\perp} \geq$ [mm]	$\alpha_g$ [-]	Konfiguracja	$c \geq$ [mm]	$s_{  } \geq$ [mm]	$\alpha_g$ [-]
	50	-	-	-	-	-	-
	50	5 d <sub>0</sub>	1,0		50	5 d <sub>0</sub>	1,0
	50	240	2,0		50	300	2,0

**Hilti HIT-HY 270 z HAS-U**

**Właściwości użytkowe cegły ceramicznej otworowej Hlz, 10DF**

Wartości charakterystyczne nośności przy obciążeniu rozciągającym oraz współczynnik grupowy

Załącznik C21

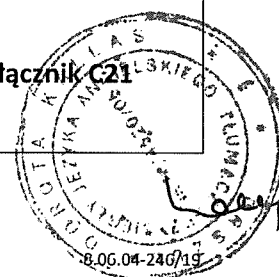

**Tabela C46: Nośność na ścinanie przy odległości od krawędzi  $c \geq 300$  mm**

Typ i rozmiar kotwy	$h_{ef}$ [mm]	$f_b$ [N/mm <sup>2</sup> ]	$V_{Rk,b} = V_{Rk,c,II} = V_{Rk,c,\perp}$ <sup>1)</sup> [kN]
HAS-UM8, M10	$\geq 80$	12	4,5
		20	5,5
HAS-U M12, M16		12	9,5
		20	10

<sup>1)</sup> Wartość  $V_{Rk,b}$  może być stosowana jako  $V_{Rk,c,\perp}$ , jeśli

- Spoiny poziome są całkowicie wypełnione zaprawą oraz
- Spoiny pionowe są całkowicie wypełnione zaprawą lub cegły stykają się bezpośrednio ze sobą.

Odpowiednia odległość od krawędzi, rozstaw oraz współczynnik grupowy  $\alpha_g$

Konfiguracja	$c \geq$ [mm]	$s_{\perp} \geq$ [mm]	$\alpha_g$ [-]	Konfiguracja	$c \geq$ [mm]	$s_{\perp} \geq$ [mm]	$\alpha_g$ [-]
	300	-	-		300	-	-
	300	240	2,0		300	240	1,0
Konfiguracja	$c \geq$ [mm]	$s_{II} \geq$ [mm]	$\alpha_g$ [-]	Konfiguracja	$c \geq$ [mm]	$s_{II} \geq$ [mm]	$\alpha_g$ [-]
	300	300	2,0		300	300	2,0

**Tabela C47: Nośność na ścinanie przy odległości od krawędzi  $c \geq 50$  mm**

Typ i rozmiar kotwy	$h_{ef}$ [mm]	$c$ [mm]	$V_{Rk,c,\perp}$ [kN]
Wszystkie kotwy	$\geq 80$	$\geq 50$	1,25
		$\geq 250$	2,5
		$c$ [mm]	$V_{Rk,b} = V_{Rk,c,II}$ [kN]
		$\geq 50$	1,25
		$\geq 100$ i $\geq 6 \cdot d_0$	2,5

Odpowiednia odległość od krawędzi, rozstaw oraz współczynnik grupowy  $\alpha_g$

Konfiguracja	$c \geq$ [mm]	$s_{\perp} \geq$ [mm]	$\alpha_g$ [-]	Konfiguracja	$c \geq$ [mm]	$s_{\perp} \geq$ [mm]	$\alpha_g$ [-]
	patrz Tabela C47	-	-		patrz Tabela C47	-	-
	patrz Tabela C47	$5 d_0$	1,0		patrz Tabela C47	$5 d_0$	1,0
	patrz Tabela C47	240	2,0		patrz Tabela C47	240	2,0
Konfiguracja	$c \geq$ [mm]	$s_{II} \geq$ [mm]	$\alpha_g$ [-]	Konfiguracja	$c \geq$ [mm]	$s_{II} \geq$ [mm]	$\alpha_g$ [-]
	patrz Tabela C47	$5 d_0$	1,0		patrz Tabela C47	$5 d_0$	1,0
	patrz Tabela C47	300	2,0		patrz Tabela C47	300	2,0

**Tabela C48: Przemieszczenia**

$h_{ef}$	$N$	$\delta_{N0}$	$\delta_{N\infty}$	$V$	$\delta_{V0}$	$\delta_{V\infty}$
[mm]	[kN]	[mm]	[mm]	[kN]	[mm]	[mm]
$\geq 80$	2,5	0,4	0,8	1,7	1,0	1,5

**Hilti HIT-HY 270 z HAS-U**

**Właściwości użytkowe cegły ceramicznej otworowej H1z, 10DF**

Wartości charakterystyczne nośności przy obciążeniu ścinającym oraz współczynnik grupowy  
Przemieszczenia

Załącznik C22

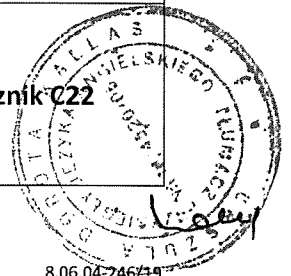

**Typ cegły: Cegła silikatowa otworowa KSL, 8DF**

**Tabela C49: Opis cegły**

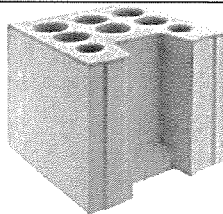



Typ cegły			KSL-12-1,4-8 DF	 <p>Ilustracja cegły, patrz <b>Tabela B4</b></p>
Gęstość objętościowa	$\rho$	[kg/dm <sup>3</sup> ]	$\geq 1,4$	
Wytrzymałość na ściskanie	$f_b$	[N/mm <sup>2</sup> ]	$\geq 12/20$	
Norma			EN 771 -2	
Producent			KS Wemding (D)	
Wymiary cegły	[mm]		248 x 240 x 238	
Minimalna grubość ściany	$h_{min}$	[mm]	$\geq 240$	

**Nośności charakterystyczne dla wszystkich kombinacji kotew (patrz Tabela B3)**

**Tabela C50: Nośność na rozciąganie przy odległości od krawędzi  $c \geq 50$  mm**

Kategoria zastosowania			w/w = w/d		d/d	
Zakres temperatury pracy			Ta	Tb	Ta	Tb
Typ i rozmiar kotwy	$h_{ef}$ [mm]	$f_b$ [N/mm <sup>2</sup> ]	$N_{Rk,p} = N_{Rk,b}$ [kN]			
HAS-U M8 do M16	$\geq 80$	12	-	-	4,0	3,0
		20	-	-	5,5	4,5
	$\geq 130$	12	-	-	5,0	4,0
		20	-	-	7,5	6,0

**Odpowiednia odległość od krawędzi, rozstaw oraz współczynnik grupowy  $\alpha_g$**

Konfiguracja	$c \geq$ [mm]	$s_{\perp} \geq$ [mm]	$\alpha_g$ [-]	Konfiguracja	$c \geq$ [mm]	$s_{  } \geq$ [mm]	$\alpha_g$ [-]
	50	-	-	-	-	-	-
	50	50	1,0		50	50	1,0
	50	240	2,0		50	250	2,0

**Tabela C51: Nośność na ścinanie przy odległości od krawędzi  $c \geq 125$  mm (dla V<sub>II</sub>) oraz  $c \geq 250$  (dla V<sub>-</sub>)**

Typ i rozmiar kotwy	$h_{ef}$ [mm]	$f_b$ [N/mm <sup>2</sup> ]	$V_{Rk,b} = V_{Rk,c,II} = V_{Rk,c,L}$ <sup>1)</sup> [kN]
HAS-U M8	$\geq 80$	12	6,0
		20	9,0
HAS-U M10		12	9,0
		20	12,0
HAS-U M12 do M16		12	12,0
		20	12,0

<sup>1)</sup> Wartość  $V_{Rk,b}$  może być stosowana jako  $V_{Rk,c,L}$ , jeśli

- Spoiny poziome są całkowicie wypełnione zaprawą oraz
- Spoiny pionowe są całkowicie wypełnione zaprawą lub cegły stykają się bezpośrednio ze sobą oraz
- maksymalna wartość  $V_{Rk,c,L} = 9$  kN

**Hilti HIT-HY 270 z HAS-U**

**Właściwości użytkowe cegły silikatowej otworowej KSL, 8DF**

Wartości charakterystyczne nośności przy obciążeniu rozciągającym i ścinającym oraz współczynnik grupowy

Załącznik C23

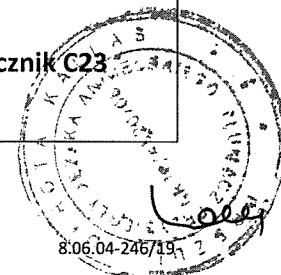

Odpowiednia odległość od krawędzi, rozstaw oraz współczynnik grupowy  $\alpha_g$

Konfiguracja	$c \geq$ [mm]	$s_{\perp} \geq$ [mm]	$\alpha_g$ [-]	Konfiguracja	$c \geq$ [mm]	$s_{\perp} \geq$ [mm]	$\alpha_g$ [-]
	125	-	-		250	-	-
	125	240	2,0	-	-	-	-
Konfiguracja	$c \geq$ [mm]	$s_{\parallel} \geq$ [mm]	$\alpha_g$ [-]	Konfiguracja	$c \geq$ [mm]	$s_{\parallel} \geq$ [mm]	$\alpha_g$ [-]
	125	250	2,0		250	250	2,0

Tabela C52: Nośność na ścinanie przy odległości od krawędzi  $c \geq 50$  mm

Typ i rozmiar kotwy	$h_{ef}$ [mm]	$c$ [mm]	$f_b$ [N/mm <sup>2</sup> ]	$V_{RK,c,\perp}$ <sup>1)</sup> [kN]
Wszystkie kotwy	$\geq 80$	$\geq 50$	12	4,0
			20	6,0
		$\geq 50$	$f_b$ [N/mm <sup>2</sup> ]	$V_{RK,b} = V_{RK,c,\parallel}$ [kN]
			12	4,0
		20	6,0	

Odpowiednia odległość od krawędzi, rozstaw oraz współczynnik grupowy  $\alpha_g$

Konfiguracja	$c \geq$ [mm]	$s_{\perp} \geq$ [mm]	$\alpha_g$ [-]	Konfiguracja	$c \geq$ [mm]	$s_{\perp} \geq$ [mm]	$\alpha_g$ [-]
	50	-	-		50	-	-
	50	50	1,0		50	50	1,0
	50	240	2,0		50	240	2,0
Konfiguracja	$c \geq$ [mm]	$s_{\parallel} \geq$ [mm]	$\alpha_g$ [-]	Konfiguracja	$c \geq$ [mm]	$s_{\parallel} \geq$ [mm]	$\alpha_g$ [-]
	50	50	1,0		50	50	1,0
	50	250	2,0		50	250	2,0

<sup>1)</sup> maks.  $V_{RK,c,\perp} = 9$  kN

Tabela C53: Przemieszczenia

$h_{ef}$	N	$\delta_{N0}$	$\delta_{N\infty}$	V	$\delta_{V0}$	$\delta_{V\infty}$
[mm]	[kN]	[mm]	[mm]	[kN]	[mm]	[mm]
80	1,0	0,3	0,6	4,3	2,0	3,0
130	2,1	0,3	0,6	4,3	2,0	3,0

Hilti HIT-HY 270 z HAS-U

Właściwości użytkowe cegły silikatowej otworowej KSL, 8DF

Wartości charakterystyczne nośności przy obciążeniu rozciągającym i ścinającym oraz współczynnik grupowy

Przemieszczenia

Załącznik C24

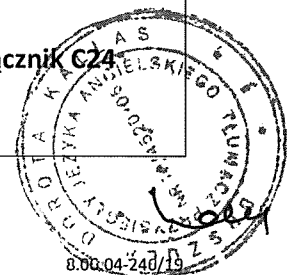

**Typ cegły: Cegła otworowa z betonu lekkiego Hbl, 16DF**

**Tabela C54: Opis cegły**

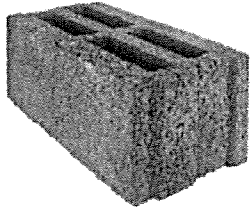
Typ cegły			Hbl-4-0,7	 <p>Ilustracja cegły, patrz <b>Tabela B4</b></p>
Gęstość objętościowa	$\rho$	[kg/dm <sup>3</sup> ]	$\geq 0,7$	
Wytrzymałość na ściskanie	$f_b$	[N/mm <sup>2</sup> ]	$\geq 2/6$	
Norma			EN 771-3	
Producent			Knobel (D)	
Wymiary cegły			[mm] 495 x 240 x 238	
Minimalna grubość ściany	$h_{min}$	[mm]	$\geq 240$	



**Nośności charakterystyczne dla wszystkich kombinacji kotew (patrz Tabela B3)**

**Tabela C55: Nośność na rozciąganie przy odległości od krawędzi  $c \geq 125$  mm**

Kategoria zastosowania			w/w = w/d		d/d	
Zakres temperatury pracy			Ta	Tb	Ta	Tb
Typ i rozmiar kotwy	$h_{ef}$ [mm]	$f_b$ [N/mm <sup>2</sup> ]	$N_{Rk,p} = N_{Rk,b}$ [kN]			
HAS-U M8 i M10,	$\geq 80$	2	3,5	3,0	4,0	3,0 (3,5*)
		6	6,0	5,0	6,5 (7,0*)	5,5 (6,0*)
HAS-U M12 i M16	$\geq 80$	2	4,0	3,5	4,5	3,5 (4,0*)
		6	7,0	6,0	8,0	6,5 (7,0*)

\* Wyłącznie czyszczenie sprężonym powietrzem (CAC)

**Odpowiednia odległość od krawędzi, rozstaw oraz współczynnik grupowy  $\alpha_g$**

Konfiguracja	$c \geq$ [mm]	$s_{\perp} \geq$ [mm]	$\alpha_g$ [-]	Konfiguracja	$c \geq$ [mm]	$s_{  } \geq$ [mm]	$\alpha_g$ [-]
	125	-	-	-	-	-	-
	125	240	2,0		125	240	2,0

**Hilti HIT-HY 270 z HAS-U**

**Właściwości użytkowe cegły otworowej z betonu lekkiego Hbl, 16DF**  
Wartości charakterystyczne nośności przy obciążeniu rozciągającym oraz współczynnik grupowy

Załącznik C25



**Tabela C56: Nośność na rozciąganie przy odległości od krawędzi  $c \geq 50$  mm**

Kategoria zastosowania			w/w = w/d		d/d	
Zakres temperatury pracy			Ta	Tb	Ta	Tb
Typ i rozmiar kotwy	$h_{ef}$ [mm]	$f_b$ [N/mm <sup>2</sup> ]	$N_{Rk,p} = N_{Rk,b}$ [kN]			
HAS-U M8 do M16	≥ 80	2	1,5	1,2	1,5	1,5
		6	2,5	2,0	3,0	2,5
	160	2	2,0	1,5	2,0	1,5 (2,0*)
		6	3,5	2,5	3,5 (4,0*)	3,0

\* Wyłącznie czyszczenie sprężonym powietrzem (CAC)

Odpowiednia odległość od krawędzi, rozstaw oraz współczynnik grupowy  $\alpha_g$

Konfiguracja	$c \geq$ [mm]	$s_{\perp} \geq$ [mm]	$\alpha_g$ [-]	Konfiguracja	$c \geq$ [mm]	$s_{\parallel} \geq$ [mm]	$\alpha_g$ [-]
	50	-	-	-	-	-	-
	50	50	1,0		50	50	1,0
	50	240	2,0		50	240	2,0

**Tabela C57: Nośność na ścinanie przy odległości od krawędzi  $c \geq 250$  mm (dla  $V_{II}$ ) oraz  $c \geq 500$  (dla  $V_{\perp}$ )**

Typ i rozmiar kotwy	$h_{ef}$ [mm]	$f_b$ [N/mm <sup>2</sup> ]	$V_{Rk,b} = V_{Rk,c \parallel} = V_{Rk,c \perp}$ [kN]
HAS-U M8, M10	≥ 80	2	4,0
		6	6,5
HAS-U M12	≥ 80	2	5,5
		6	9,5
HAS-U M16	≥ 80	2	6,0
		6	10,0

<sup>1)</sup> Wartość  $V_{Rk,b}$  może być stosowana jako  $V_{Rk,c \perp}$ , jeśli

- Spoiny poziome są całkowicie wypełnione zaprawą oraz
- Spoiny pionowe są całkowicie wypełnione zaprawą lub cegły stykają się bezpośrednio ze sobą.

Odpowiednia odległość od krawędzi, rozstaw oraz współczynnik grupowy  $\alpha_g$

Konfiguracja	$c \geq$ [mm]	$s_{\perp} \geq$ [mm]	$\alpha_g$ [-]	Konfiguracja	$c \geq$ [mm]	$s_{\perp} \geq$ [mm]	$\alpha_g$ [-]
	250	-	-		500	-	-
	250	240	2,0		500	240	1,0
Konfiguracja	$c \geq$ [mm]	$s_{\parallel} \geq$ [mm]	$\alpha_g$ [-]	Konfiguracja	$c \geq$ [mm]	$s_{\parallel} \geq$ [mm]	$\alpha_g$ [-]
	250	250	2,0		500	500	2,0

Hilti HIT-HY 270 z HAS-U

Właściwości użytkowe cegły otworowej z betonu lekkiego Hbl, 16DF

Wartości charakterystyczne nośności przy obciążeniu rozciągającym i ścinającym oraz współczynnik grupowy

Załącznik C26

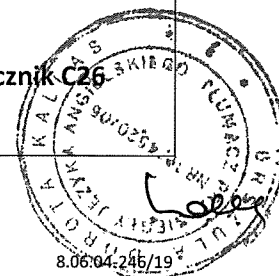



Europejska Ocena Techniczna

ETA-19/0160

Tłumaczenie na język angielski opracowane przez DIBt

Tłumaczenie z języka angielskiego na język polski wykonano na zlecenie Hilti

Strona 48 z 51 | 30 sierpnia 2019 r.

**Tabela C58: Nośność na ścinanie przy odległości od krawędzi  $c \geq 50$  mm**

Typ i rozmiar kotwy	$h_{ef}$ [mm]	$c$ [mm]	$f_b$ [N/mm <sup>2</sup> ]	$V_{Rk,c,\perp}$ [kN]
Wszystkie kotwy	$\geq 80$	$\geq 50$	2	1,5
			6	3,0
		$\geq 250$	2	2,5
			$c$ [mm]	$f_b$ [N/mm <sup>2</sup> ]
		$\geq 50$	2	1,5
			6	3,0
		$\geq 100$	2	2,5
		$\geq 6 d_0$		

Odpowiednia odległość od krawędzi, rozstaw oraz współczynnik grupowy  $\alpha_g$

Konfiguracja	$c \geq$ [mm]	$s_{\perp} \geq$ [mm]	$\alpha_g$ [-]	Konfiguracja	$c \geq$ [mm]	$s_{\perp} \geq$ [mm]	$\alpha_g$ [-]
	patrz Tabela C58	-	-		patrz Tabela C58	-	-
	patrz Tabela C58	50	1,0		patrz Tabela C58	50	1,0
	patrz Tabela C58	240	2,0		patrz Tabela C58	240	2,0
Konfiguracja	$c \geq$ [mm]	$s_{\parallel} \geq$ [mm]	$\alpha_g$ [-]	Konfiguracja	$c \geq$ [mm]	$s_{\parallel} \geq$ [mm]	$\alpha_g$ [-]
	patrz Tabela C58	50	1,0		patrz Tabela C58	50	1,0
	patrz Tabela C58	250	2,0		patrz Tabela C58	250	2,0

**Tabela C59: Przemieszczenia**

$h_{ef}$	<b>N</b>	$\delta_{N0}$	$\delta_{N\infty}$	<b>V</b>	$\delta_{V0}$	$\delta_{V\infty}$
[mm]	[kN]	[mm]	[mm]	[kN]	[mm]	[mm]
80	0,8	0,20	0,4	2,3	1,0	1,5
160	1,1	0,25	0,5	2,3	1,0	1,5

Hilti HIT-HY 270 z HAS-U

Właściwości użytkowe cegły otworowej z betonu lekkiego Hbl, 16DF

Wartości charakterystyczne nośności przy obciążeniu ścinającym oraz współczynnik grupowy

Przemieszczenia

Załącznik C27



**Typ cegły: Cegła otworowa z betonu zwykłego - parpaing creux**

**Tabela C60: Opis cegły**

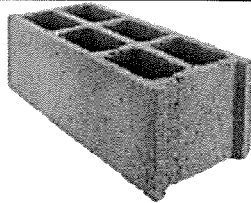

Typ cegły		B40	 Ilustracja cegły, patrz Tabela B4	
Gęstość objętościowa	$\rho$	[kg/dm <sup>3</sup> ]		$\geq 0,9$
Wytrzymałość na ściskanie	$f_b$	[N/mm <sup>2</sup> ]		$\geq 4/10$
Norma		EN 771-3		
Producent		Fabemi (F)		
Wymiary cegły		[mm]		500 x 200 x 200
Minimalna grubość ściany	$h_{min}$	[mm]		$\geq 200$

**Nośności charakterystyczne dla wszystkich kombinacji kotew (patrz Tabela B3)**

**Tabela C61: Nośność na rozciąganie przy odległości od krawędzi  $c \geq 50$  mm**

Kategoria zastosowania			w/w = w/d		d/d	
Zakres temperatury pracy			Ta	Tb	Ta	Tb
Typ i rozmiar kotwy	$h_{ef}$ [mm]	$f_b$ [N/mm <sup>2</sup> ]	$N_{Rk,p} = N_{Rk,b}$ [kN]			
Wszystkie kotwy	$\geq 50$	4	0,9	0,9	0,9	0,9
		10	2,0	1,5	2,0	1,5
Wszystkie kotwy	$\geq 130$	4	1,5	1,2	1,5	1,2
		10	2,5	2,0	2,5	2,0

**Odpowiednia odległość od krawędzi, rozstaw oraz współczynnik grupowy  $\alpha_g$**

Konfiguracja	$c \geq$ [mm]	$s_{\perp} \geq$ [mm]	$\alpha_g$ [-]	Konfiguracja	$c \geq$ [mm]	$s_{  } \geq$ [mm]	$\alpha_g$ [-]
	50	-	-	-	-	-	-
	50	200	2,0		50	200	2,0

**Tabela C62: Nośność na ścinanie przy odległości od krawędzi  $c \geq 200$  mm (dla V<sub>II</sub>) oraz  $c \geq 500$  (dla V<sub>-</sub>)**

Typ i rozmiar kotwy	$h_{ef}$ [mm]	$f_b$ [N/mm <sup>2</sup> ]	$V_{Rk,b} = V_{Rk,c,II} = V_{Rk,c,-}^{1)}$ [kN]
Wszystkie kotwy	$\geq 50$	4	4
		10	6,5
	$\geq 80$	4	5
		10	7,5

<sup>1)</sup> Wartość  $V_{Rk,b}$  może być stosowana jako  $V_{Rk,c,-}$ , jeśli

- Spoiny poziome są całkowicie wypełnione zaprawą oraz
- Spoiny pionowe są całkowicie wypełnione zaprawą lub cegły stykają się bezpośrednio ze sobą.

Hilti HIT-HY 270 z HAS-U

**Właściwości użytkowe cegły otworowej z betonu zwykłego - parpaing creux**

Wartości charakterystyczne nośności przy obciążeniu rozciągającym i ścinającym oraz współczynnik grupowy

Załącznik C28

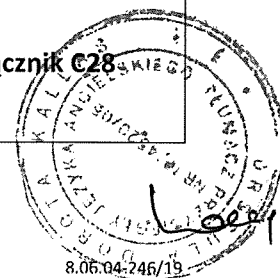

Odowiednia odległość od krawędzi, rozstaw oraz współczynnik grupowy  $\alpha_g$

Konfiguracja	$c \geq$ [mm]	$s_{\perp} \geq$ [mm]	$\alpha_g$ [-]	Konfiguracja	$c \geq$ [mm]	$s_{\perp} \geq$ [mm]	$\alpha_g$ [-]
	200	-	-		500	-	-
	200	200	2,0		500	200	1,0
Konfiguracja	$c \geq$ [mm]	$s_{\parallel} \geq$ [mm]	$\alpha_g$ [-]	Konfiguracja	$c \geq$ [mm]	$s_{\parallel} \geq$ [mm]	$\alpha_g$ [-]
	200	200	2,0		500	500	2,0

Tabela C63: Nośność na ścinanie przy odległości od krawędzi  $c \geq 50$  mm

Typ i rozmiar kotwy	$h_{ef}$ [mm]	$c$ [mm]	$f_b$ [N/mm <sup>2</sup> ]	$V_{Rk,c,\perp}$ [kN]
Wszystkie kotwy	$\geq 50$	$\geq 50$	4	1,2
			10	1,5
		$\geq 250$	4/10	2,5
		$c$ [mm]	$f_b$ [N/mm <sup>2</sup> ]	$V_{Rk,b} = V_{Rk,c,\parallel}$ [kN]
		$\geq 50$	4	2,0
			10	3,0

Odowiednia odległość od krawędzi, rozstaw oraz współczynnik grupowy  $\alpha_g$

Konfiguracja	$c \geq$ [mm]	$s_{\perp} \geq$ [mm]	$\alpha_g$ [-]	Konfiguracja	$c \geq$ [mm]	$s_{\perp} \geq$ [mm]	$\alpha_g$ [-]
	50	-	-		patrz Tabela C63	-	-
	50	50	1,0		patrz Tabela C63	50	1,0
	50	200	2,0		patrz Tabela C63	200	2,0
Konfiguracja	$c \geq$ [mm]	$s_{\parallel} \geq$ [mm]	$\alpha_g$ [-]	Konfiguracja	$c \geq$ [mm]	$s_{\parallel} \geq$ [mm]	$\alpha_g$ [-]
	50	50	1,0		patrz Tabela C63	50	1,0
	50	200	2,0		patrz Tabela C63	200	2,0

Tabela C64: Przemieszczenia

$h_{ef}$	$N$	$\delta_{N0}$	$\delta_{N\infty}$	$V$	$\delta_{V0}$	$\delta_{V\infty}$
[mm]	[kN]	[mm]	[mm]	[kN]	[mm]	[mm]
$\geq 50$	0,7	0,5	1,0	1,7	1,0	1,5

Hilti HIT-HY 270 z HAS-U

Właściwości użytkowe cegły otworowej z betonu zwykłego - parpaing creux

Wartości charakterystyczne nośności przy obciążeniu ścinającym oraz

współczynnik grupowy

Przemieszczenia

Załącznik C29<sup>5</sup>

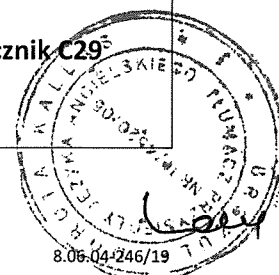

**Typ cegły: Cegła ceramiczna otworowa - stropowa**

**Tabela C65: Opis cegły**

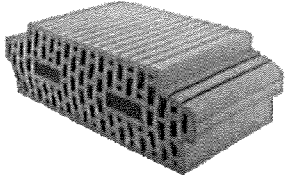
Typ cegły		Ds-1,0	 Ilustracja cegły, patrz <b>Tabela B4</b>
Gęstość objętościowa	$\rho \geq$ [kg/dm <sup>3</sup> ]	1,0	
Wytrzymałość		DIN EN 15037-3, klasa R2	
Norma		DIN 4160	
Producent		Fiedler Marktrechwitz (D)	
Wymiary cegły	[mm]	510 x 250 x 180	
Min. grubość stropu	$h_{min} \geq$ [mm]	$\geq 180$	

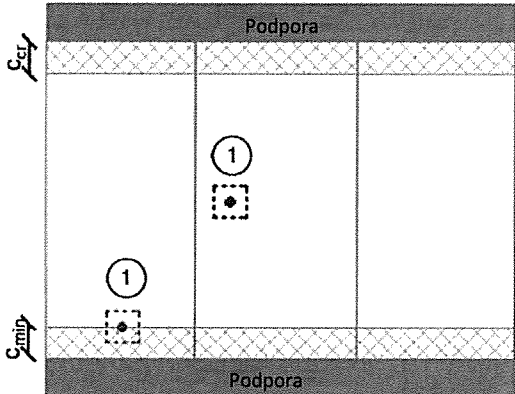
	① Pojedynczy element mocujący Maksymalnie jedna kotwa na cegłę stropową
--	--

**Tabela C66: Parametry montażu dla wszystkich kombinacji kotew (patrz Tabela B3)**

Typ kotwy		HAS-U M6 z HIT-SC 12x85
Odległość od krawędzi	$c_{min} = c_{cr}$ [mm]	100 od podpory
Rozstaw $A_c$	$s_{min \parallel}$ [mm]	510
	$s_{min \perp} = s_{cr}$ [mm]	250

**Tabela C67: Współczynnik grupowy**

Współczynnik grupowy $\alpha_{q,N \parallel} \alpha_{q,V \parallel} \alpha_{q,N \perp} \alpha_{q,V \perp}$ [-]	1
--	---

**Tabela C68: Nośność charakterystyczna na rozciąganie dla wszystkich kombinacji kotew (patrz Tabela B3)**

Kategoria zastosowania			w/w		d/d	
Zakres temperatury pracy			Ta	Tb	Ta	Tb
Typ i rozmiar kotwy	$h_{ef}$ [mm]	Nośność wspornika [kN]	$N_{Rk,p} = N_{Rk,b}$ [kN]			
Wszystkie kotwy	$\geq 80$	3	1,5	1,5	1,5	1,5

**Tabela C69: Przemieszczenia**

$h_{ef}$	N	$\delta_{N0}$	$\delta_{N\infty}$
[mm]	[kN]	[mm]	[mm]
$\geq 80$	0,4	0,15	0,30

**Hilti HIT-HY 270 z HAS-U**

**Właściwości użytkowe cegły ceramicznej otworowej - stropowej**  
 Wartości charakterystyczne nośności przy obciążeniu rozciągającym  
 Przemieszczenia

Załącznik C30

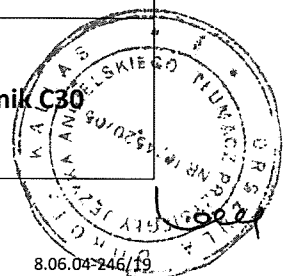

Ja, Urszula Dorota Kallas, tłumacz przysięgły języka angielskiego i francuskiego,  
wpisana na listę tłumaczy przysięgłych Ministra Sprawiedliwości pod numerem  
TP/4520/05, stwierdzam, że niniejsze tłumaczenie w pełni odpowiada przedstawionemu  
mi oryginałowi dokumentu w języku angielskim  
Warszawa, 28.10.2019r.; Rep. Nr 888/2019

