

Approval body for construction products  
and types of construction

Bautechnisches Prüfamnt

An institution established by the Federal and  
Laender Governments



## European Technical Assessment

ETA-07/0336  
of 7 October 2015

English translation prepared by DIBt - Original version in German language

### General Part

Technical Assessment Body issuing the  
European Technical Assessment:

Deutsches Institut für Bautechnik

Trade name of the construction product

Insulation support TFIX-8M

Product family  
to which the construction product belongs

Nailed-in plastic anchor for fixing of external thermal  
insulation composite systems with rendering in concrete  
and masonry

Manufacturer

RAWLPLUG S.A.  
Kwidzynska 6  
51-416 WROCLAW  
POLEN

Manufacturing plant

RAWLPLUG S.A.  
Kwidzynska 6  
51-416 Wroclaw  
POLEN

This European Technical Assessment  
contains

14 pages including 3 annexes which form an integral part  
of this assessment

This European Technical Assessment is  
issued in accordance with Regulation (EU)  
No 305/2011, on the basis of

Guideline for European technical approval of "Plastic  
anchors for fixing of external thermal insulation composite  
systems with rendering", ETAG 014, February 2011,  
used as European Assessment Document (EAD)  
according to Article 66 Paragraph 3 of Regulation (EU)  
No 305/2011.

The European Technical Assessment is issued by the Technical Assessment Body in its official language. Translations of this European Technical Assessment in other languages shall fully correspond to the original issued document and shall be identified as such.

Communication of this European Technical Assessment, including transmission by electronic means, shall be in full. However, partial reproduction may only be made with the written consent of the issuing Technical Assessment Body. Any partial reproduction shall be identified as such.

This European Technical Assessment may be withdrawn by the issuing Technical Assessment Body, in particular pursuant to information by the Commission in accordance with Article 25(3) of Regulation (EU) No 305/2011.

## Specific part

### 1 Technical description of the product

The insulation support TFIX-8M is a nailed-in anchor which consists of a plastic part made of polypropylene and an accompanying specific nail of galvanised steel. The head of the nail has an additional plastic coating.

The anchor may in addition be combined with the anchor plates KWL 90, KWL 110 and KWL 140.

The description of the product is given in Annex A.

### 2 Specification of the intended use in accordance with the applicable European Assessment Document

The performances given in Section 3 are only valid if the anchor is used in compliance with the specifications and conditions given in Annex B.

The verifications and assessment methods on which this European Technical Assessment is based lead to the assumption of a working life of the anchor of at least 25 years. The indications given on the working life cannot be interpreted as a guarantee given by the producer, but are to be regarded only as a means for choosing the right products in relation to the expected economically reasonable working life of the works.

### 3 Performance of the product and references to the methods used for its assessment

#### 3.1 Mechanical resistance and stability (BWR 1)

The essential characteristics regarding mechanical resistance and stability are included under the Basic Works Requirement Safety in use.

#### 3.2 Hygiene, health and the environment (BWR 3)

Regarding dangerous substances there may be requirements (e.g. transposed European legislation and national laws, regulations and administrative provisions) applicable to the products falling within the scope of this European Technical Assessment. In order to meet the provisions of Regulation (EU) No 305/2011, these requirements need also to be complied with, when and where they apply.

#### 3.3 Safety and accessibility in use (BWR 4)

Essential characteristic	Performance
Characteristic resistance	See Annex C 1
Edge distances and spacing	See Annex B 2
Point thermal transmittance	See Annex C 2
Displacements	See Annex C 2

#### 3.4 Sustainable use of natural resources (BWR 7)

For the sustainable use of natural resources no performance was determined for this product.

**4 Assessment and verification of constancy of performance (AVCP) system applied, with reference to its legal base**

In accordance with guideline for European technical approval ETAG 014, February 2011 used as European Assessment Document (EAD) according to Article 66 Paragraph 3 of Regulation (EU) No 305/2011 the applicable European legal act is: 97/463/EC.

The system to be applied is: 2+

**5 Technical details necessary for the implementation of the AVCP system, as provided for in the applicable EAD**

Technical details necessary for the implementation of the AVCP system are laid down in the control plan deposited with Deutsches Institut für Bautechnik.

Issued in Berlin on 7 October 2015 by Deutsches Institut für Bautechnik

Uwe Bender  
Head of Department

*beglaubigt:*  
Aksünger

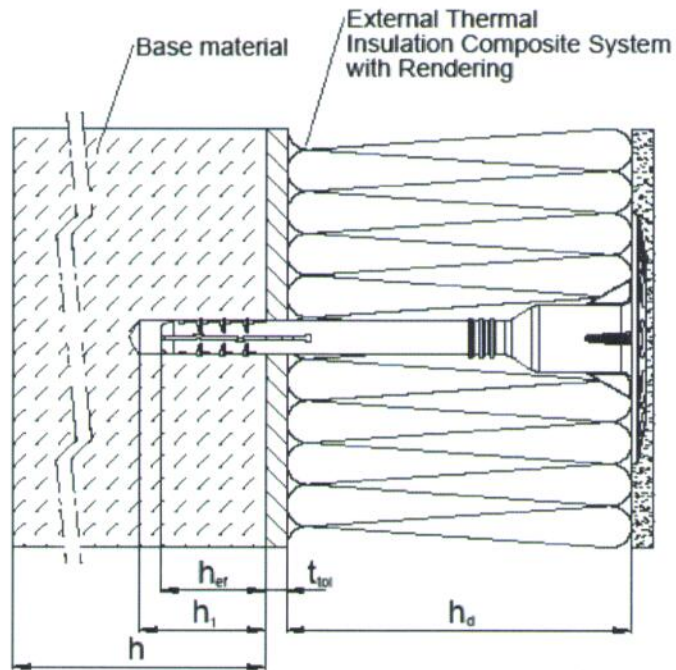

Legend

- $h_{ef}$  = effective anchorage depth
- $h$  = thickness of member (wall)
- $h_1$  = depth of drilled hole to deepest point
- $h_d$  = thickness of insulation material
- $t_{tol}$  = thickness of equalizing layer or non-load-bearing coating

Insulation support TFIX-8M

Product description  
 Installed condition

Annex A 1

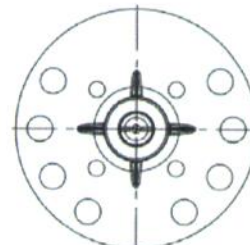
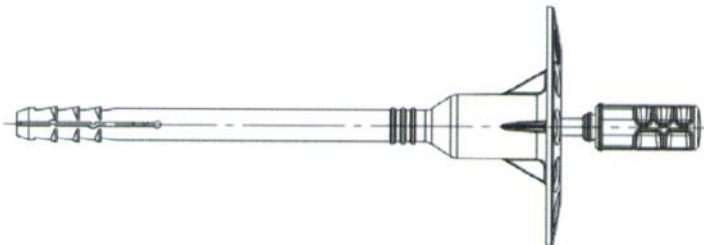

Marking identifying: mark of plant  
Anchor type (TFIX-8M)  
Length of anchor (z.B. 135)

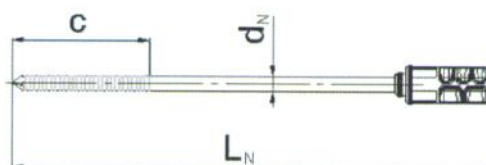
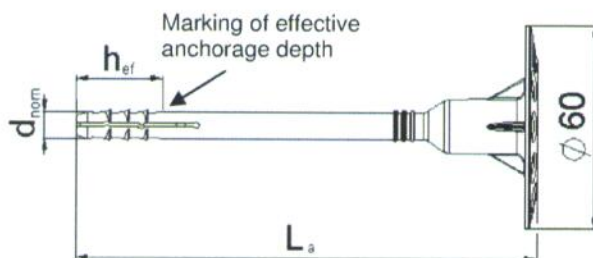

**Insulation support TFIX-8M**

**Product description**  
Anchor sleeve and expansion element

**Annex A 2**

**Table A1: Dimension [mm]**

Anchor type	Anchor sleeve		Accompanying expansion nail	
	$d_{nom}$	$h_{ef}$	$d_N$	c
TFIX-8M	8	25	4,2	45

Various lengths of the anchor are permissible:

$$L_{a \min} = 75\text{mm}; L_{a \max} = 295\text{mm}$$

Determination of max. thickness of insulation:

$$h_d = L_a - t_{tol} - h_{ef}$$

$$\text{e.g. } L_a = 135\text{mm}$$

$$t_{tol} = 10\text{mm}$$

$$h_d = 135\text{mm} - 10\text{mm} - 25\text{mm}$$

$$h_d = 100\text{mm}$$

**Table A2: Materials**

Name	Materials
Anchor sleeve	Polypropylen Colour natural
Expansion nail	Steel $\geq 5\mu\text{m}$ according to EN ISO 4042:2001 Head of nail: Coating of polyamide with glass fiber reinforced, colour natural

**Insulation support TFIX-8M**

**Product description**  
Dimension, materials

**Annex A 3**

KWL - 90

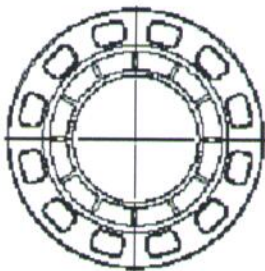

KWL - 110

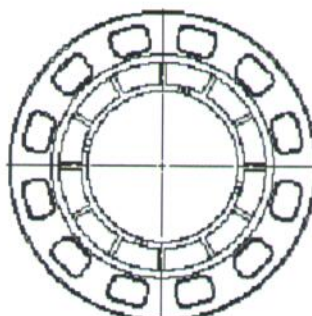

KWL - 140

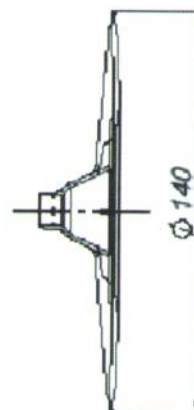
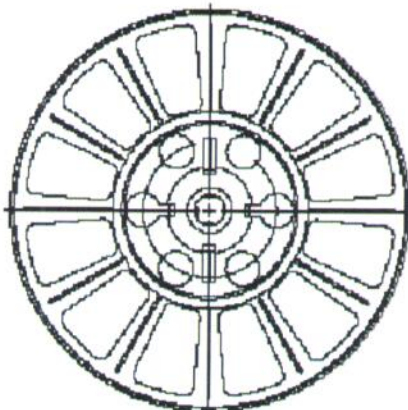

Table A3: Additional plates, diameter and materials

Plate	Diameter	Colour	Materials
KWL-90	90	nature	PA6 + GF, PP
KWL-110	110	nature	
KWL-140	140	nature	

Insulation support TFIX-8M

Product description  
Slip on plates combined with TFIX-8M

Annex A 4



### Specifications of intended use

**Anchorage subject to:**

- The anchor may only be used for transmission of wind suction loads and shall not be used for the transmission of dead loads of the thermal insulation composite system.

**Base materials:**

- Normal weight concrete (use category A) according to Annex C 1.
- Solid masonry (use category B), according to Annex C 1.
- Hollow or perforated masonry (use category C), according to Annex C 1.
- For other base materials of the use categories B or C the characteristic resistance of the anchor may be determined by job site tests according to ETAG 014 Edition February 2011, Annex D.

**Temperature Range:**

- 0°C to +40°C (max. short term temperature +40°C and max. long term temperature +24°C)

**Design:**

- The anchorages are designed in accordance with the ETAG 014 Edition February 2011 under the responsibility of an engineer experienced in anchorages and masonry work.
- Verifiable calculation notes and drawings are prepared taking account of the loads to be anchored. The position of the anchor is indicated on the design drawings.
- Fasteners are only to be used for multiple fixings of thermal insulation composite systems.

**Installation:**

- Hole drilling by the drill modes according to Annex B.3
- Anchor installation carried out by appropriately qualified personnel and under the supervision of the person responsible for technical matters of the site.
- Installation temperature from 0°C to +40°C
- Exposure to UV due to solar radiation of the anchor not protected by rendering  $\leq 6$  weeks

Insulation support TFIX-8M

Intended use  
Specifications

Annex B 1

**Table B1: Installation parameters**

Anchore type		TFIX-8M
Drill hole diameter	$d_o = [\text{mm}]$	8
Cutting diameter of drill bit	$d_{\text{cut}} < [\text{mm}]$	8,45
Depth of drilled hole to deepest point	$h_1 > [\text{mm}]$	35
Effective anchorage depth	$h_{\text{ef}} \geq [\text{mm}]$	25

**Table B2: Anchor distances and dimensions of members**

Anchore type		TFIX-8M
Minimum spacing	$s_{\text{min}} = [\text{mm}]$	100
Minimum edge distance	$c_{\text{min}} = [\text{mm}]$	100
Minimum thickness of member	$h = [\text{mm}]$	100

**Scheme of distances and spacing**

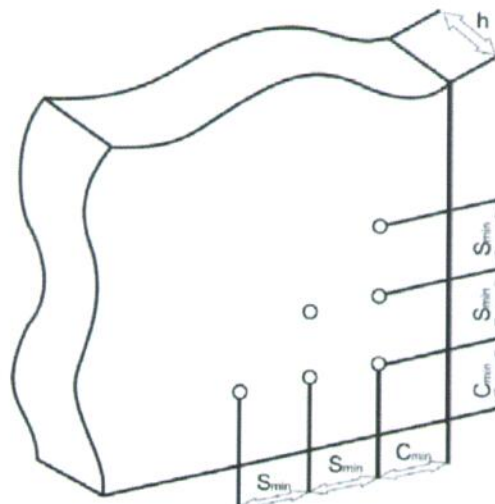

**Insulation support TFIX-8M**

**Intended use**  
Installation parameters, Edge distances and spacing

**Annex B 2**

### Installation instructions

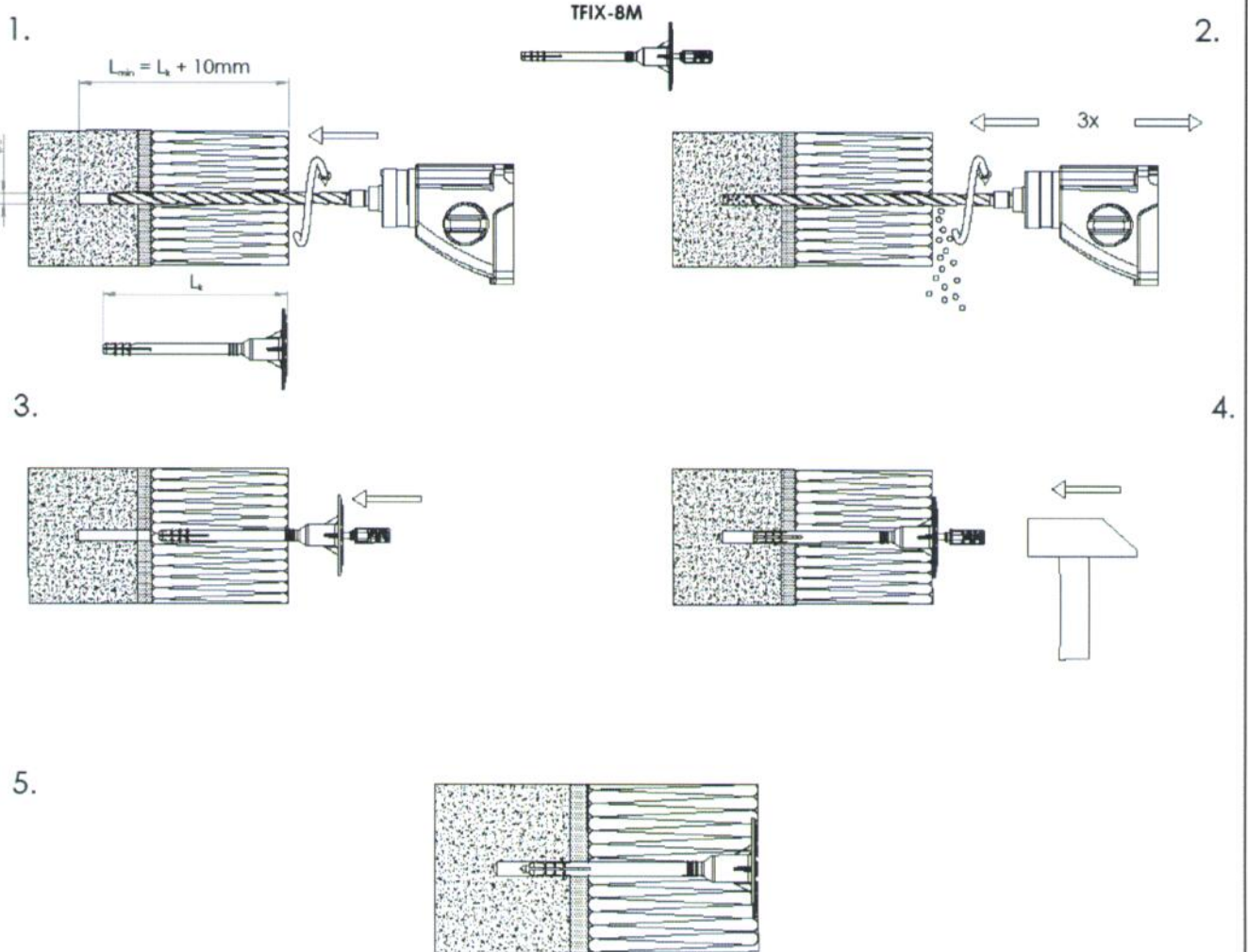

- 1) Drill hole perpendicular to the substrate surface
- 2) Clean the drill hole 3x
- 3) Put TFIX-8M into hole
- 4) Drive in the anchor with the hammer
- 5) The bottom side of the plate must be flush with the ETICS  
Installed condition of the TFIX-8M

**Insulation support TFIX-8M**

**Intended use**  
Installation instructions

**Annex B 3**

**Table C1: Characteristic resistance to tension loads  $N_{Rk}$  [kN] in concrete and masonry for single anchor**

Anchor type					TFIX-8M
Base material	Bulk density class $\rho$ [kg/dm <sup>3</sup> ]	Minimum compressive strength $f_b$ [N/mm <sup>2</sup> ]	General remarks	Drilling method <sup>(3)</sup>	$N_{Rk}$ [kN]
concrete C12/15 – C50/60 EN 206:2013				H	1,2
Clay brick, Mz e.g. according DIN 105-100:2012-01 / EN 771-1: 2011	≥ 2,0	12	Vertically perforation up to 15%	H	1,2
Sand-lime solid bricks (calcium silikate), KS e.g. according DIN V 106:2005-10/ EN 771-2:2011	≥ 1,8	12	Vertically perforation up to 15%	H	1,2
Sand-lime solid bricks (calcium silikate), KSL e.g. according DIN V 106:2005-10/ EN 771-2:2011	≥ 1,6	12	Vertically perforation up to 15%, with outer web thickness of ≥ 20mm	H	0,9
Perforated clay bricks, HLz e.g. according DIN 105-100:2012-01 / EN 771-1: 2011	≥ 1,0	12	Vertically perforation more than 15%, and less than 50% <sup>(1)</sup>	D	0,6
Lightweight concrete solid block, Vbl e.g. according DIN V 18152-100:2005-10/ EN 771-3:2011	≥ 0,7	4	Proportion of handle hole to resting area up to 10%, maximum size of handle hole: 110x45mm	D	0,3
Lightweight concrete hollow block, Hbl, e.g. according DIN V 18151-100:2005-10/ EN 771-3:2011	≥ 0,9	2	According to annex C 3 <sup>(2)</sup>	D	0,5
Lightweight concrete solid brick, V e.g. according DIN V 18152-100:2005-10/ EN 771-3:2011	≥ 1,2	6	Proportion of handle hole to resting area up to 10%, maximum size of handle hole: 110x45mm	H	0,5
Partial safety factor <sup>(4)</sup>					2,0

(1) With outer web thickness ≥ 14mm

(2) Exterior web thickness ≥ 35mm

(3) H = hammer drill, D = rotary drill

(4) In absence of national regulations

**Insulation support TFIX-8M**

**Performances**

Characteristic bending resistance of the anchor

**Annex C 1**

**Table C2: Point thermal transmittance according EOTA Technical Report TR 025:2007-06**

Anchor type	Insulation thickness $h_d$ [mm]	Point thermal transmittance $\chi$ [W/K]
TFIX-8M	50 - 270	0,002

**Table C3: Plate stiffness according EOTA TR 026:2007-06**

Anchor type	Diameter of the anchor plate [mm]	Load resistance of the anchor plate [kN]	Plate stiffness [kN/mm]
TFIX-8M	60	1,75	1,0

**Table C4: Displacements**

Anchor type	Bulk density class $\rho$ [kg/dm <sup>3</sup> ]	Minimum compressive strength $f_b$ [N/mm <sup>2</sup> ]	Tension load  N [kN]	Displacements  $\delta_m(N)$ [mm]
Concrete C12/15 - C50/60 EN 206:2013			0,40	0,5
Clay brick, Mz e.g. according DIN 105-100:2012-01 / EN 771-1: 2011	≥ 2,0	12	0,40	0,7
Sand-lime solid bricks (calcium silikate), KS e.g. according DIN V 106:2005-10/ EN 771-2:2011	≥ 1,8	12	0,40	0,8
Sand-lime solid bricks (calcium silikate), KSL e.g. according DIN V 106:2005-10/ EN 771-2:2011	≥ 1,4	12	0,30	0,4
Perforated clay bricks, HLz e.g. according DIN 105-100:2012-01 / EN 771-1: 2011	≥ 1,0	12	0,20	0,6
Lightweight concrete solid block, Vbl e.g. according DIN V 18152-100:2005-10/ EN 771-3:2011	≥ 0,7	4	0,10	0,2
Lightweight concrete hollow block, Hbl, e.g. according DIN V 18151-100:2005-10/ EN 771-3:2011	≥ 0,9	2	0,15	0,3
Lightweight concrete solid brick, V e.g. according DIN V 18152-100:2005-10/ EN 771-3:2011	≥ 1,2	6	0,15	0,3

**Insulation support TFIX-8M**

**Performances**

Point thermal transmittance, plate stiffness and displacements, displacements

**Annex C 2**

**Table C5: Assignment type of anchor and geometry of bricks for lightweight-concrete hollow blocks according to DIN V 18151-100:2005-10**

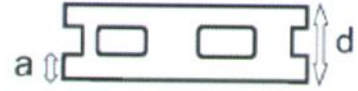
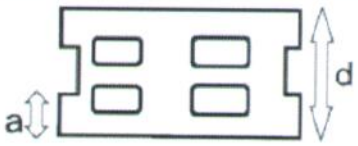
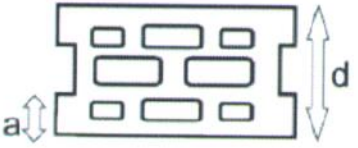
Geometry	Thickness of bricks d [mm]	Outer web in longitudinal direction a [mm]
	175	50
	240 300	50
	365	35
	240 300 365	35
	240 300 365	35

The anchor shall be placed in a way that spreading part is anchored in the web of the brick

**Insulation support TFIX-8M**

**Intended use**  
Geometry and dimensions of hollow or perforated brick

**Annex C 3**